

NATURAL GAS AND GAS PIPING

Table of Contents

	Page
1.0 SCOPE	3
1.1 Changes	3
2.0 LOSS PREVENTION RECOMMENDATIONS	3
2.1 Construction and Location	3
2.1.1 General	3
2.1.2 Piping Materials	3
2.2 Equipment and Processes	5
2.2.1 Earthquake Protection	5
2.2.2 Corrosion Protection	5
2.2.3 Buried Pipe	5
2.2.4 Building Entrances	6
2.2.5 Indoor Piping	7
2.2.6 Equipment Valves	8
2.2.7 Meters	9
2.2.8 Pressure Regulators	10
2.2.9 Gas Wells	11
2.2.10 High Pressure Gas Transmission Lines	12
2.2.11 Low Pressure Gas Holders	12
2.2.12 Waterless Holders	12
2.2.13 Pressure Holders	12
2.2.14 Emergency Shutoff Valves	12
2.2.15 Compressed Natural Gas (CNG) Trailers and Modules	13
2.3 Operation and Maintenance	13
2.3.1 Testing	13
2.4 Human Element	13
2.4.1 Emergency Procedures for Gas Leaks or Fires	13
3.0 SUPPORT FOR RECOMMENDATIONS	14
3.1 Description and Hazards of Natural Gas and Gas Piping	14
3.1.1 Explosions from Leaks in Buried Pipe	14
3.1.2 Corrosion	14
3.1.3 Compressed Natural Gas Trailers and Modules (Virtual Pipeline, Portable Pipeline)	14
3.1.4 Natural Gas Wells	15
3.1.5 Earthquake	15
3.1.6 Gasholders	16
3.1.7 Pressure Holders 1 psi (6.89 kPa, 69 mb) and Over	16
3.2 Illustrative Losses	16
3.2.1 Residential Explosion Caused by Separated Gas Line	16
3.2.2 Corroded Gas Main Fails	16
3.2.3 Cast Iron Gas Pipe Fails	16
4.0 REFERENCES	16
4.1 FM	16
4.2 NFPA Standards	16
4.3 Others	16
APPENDIX A GLOSSARY OF TERMS	17



APPENDIX B DOCUMENT REVISION HISTORY 17

List of Figures

Fig. 2.1.2.2-1. Standardized mechanical joint for cast iron pipe. 4
Fig. 2.1.2.4-1. Dresser coupling. 4
Fig. 2.2.2.4-1. Sealing pipe passing through wet floor. 6
Fig. 2.2.4.2-1. Gas pipe entrance into buildings with crawl or unfrequented basement space 7
Fig. 2.2.4.4-1. Cased buried gas-service entrance to building with floor slab on grade. 8
Fig. 2.2.5.4-1. Ventilation of crawlspace containing gas piping. 9
Fig. 2.2.6.2-1. Recommended interconnection arrangement for natural gas and LP-gas. 9
Fig. 2.2.7.3-1. Protecting meters against overpressure. 10
Fig. 2.2.7.4-1. Protecting meters against back pressure. 10
Fig. 2.2.8.3-1. Venting pressure regulators. 11
Fig. 3.1.2-1. Two methods of cathodic protection. 15

List of Tables

Table 2.2.15.1. Separation Between CNG Bulk Storage and or Decompression Equipment and Exposures . 13

1.0 SCOPE

This data sheet covers natural gas piping systems and includes general piping and service devices, buried piping and building entrances, earthquake, exposures, corrosion protection, gas wells, gas holders, testing and emergency procedures for gas leaks or fires.

This data sheet also covers systems using manufactured gas, coke oven gas, blast furnace gas and synthetic natural gas.

American National Standards Institute (ANSI) publications are referred to in this standard. The dates of the current standard are included. It is not the intent to restrict the application of future standards as appropriate to this subject.

1.1 Changes

January 2023. Interim revision. Added recommendations for location of compressed natural gas supply trailers and modules (Section 2.2.15)..

2.0 LOSS PREVENTION RECOMMENDATIONS

2.1 Construction and Location

2.1.1 General

2.1.1.1 Obtain information on piping design, manufacture, installation, and testing from ANSI Z223.1/NFPA 54-2015, *National Fuel Gas Code*; ANSI/ASME B31.1-2012, *Power Piping*; and ANSI/ASME B31.8-2014, *Gas Transmission and Distribution Piping Systems*. Those codes contain references to appropriate ASTM (American Society for Testing and Materials) standards for pipe and fitting specifications.

2.1.1.2 Do not install natural gas piping under buildings. If unavoidable, encase the pipe in conduit to withstand imposed loads. The conduit should be terminated at least 4 in. (10.2 mm) outside the building. Seal the space between the pipe and conduit and vent the annular space to out-of-doors, abovegrade.

2.1.1.3 Protect all piping from corrosion by location or coating. For underground piping, corrosion protection may be by location, proper backfill, cathodic protection or coating.

2.1.1.4 Bury gas service piping in a separate trench located as far as practical from other underground services such as steam, water, sewer, or electric.

2.1.1.5 To prevent condensate from freezing in pipes, piping should be pitched uniformly back to mains or to drip pots. Avoid indoor drip pots. Drains or vents from indoor pots should be piped out-of-doors (Fig. 4).

2.1.2 Piping Materials

2.1.2.1 Do not use cast iron pipe except as permitted by ANSI/ASME B31.8, *Gas Transmission and Distribution Pipelines*.

2.1.2.2 Ductile (modular) centrifugally cast iron pipe should not be less than 3 in. (76.2 mm) and should not be welded. Equip it with standard mechanical joints and install underground.

Do not install ductile cast iron pipe in unstable soils, located under buildings, or extend through building walls or foundations. The pipe wall thickness should be as specified for the method of laying chosen. The normal mechanical joint consists of a cast iron gland bolted to the pipe bell and a special rubber gasket (Fig. 2.1.2.2-1).

2.1.2.3 Steel and wrought iron pipe should be at least Schedule 40, standard weight for service pressures up to 125 psig (862 kPa, 8.6 bar); for higher pressures, steel piping should be according to ANSI/ASME B31.1, *Power Piping* and ANSI/ASME B31.8, *Gas Transmission and Distribution Systems*.

2.1.2.4 Welded joints or Dresser couplings (Fig. 2.1.2.4-1) should be used on buried steel pipe. The Dresser coupling or its equivalent should be braced or anchored at points where gas pressure tends to force it apart. Welded joints are preferred for aboveground use, but screw fittings of cast or forged steel, malleable iron, or bronze may be used. Gray or white cast iron fittings should not be used.

2.1.2.5 Copper and brass piping and tubing should not be used for design pressures over 100 psig (689 kPa, 6.9 bar), nor if there is more than an average of 0.3 grain (0.0194 grams) of hydrogen sulfide per 100 ft³

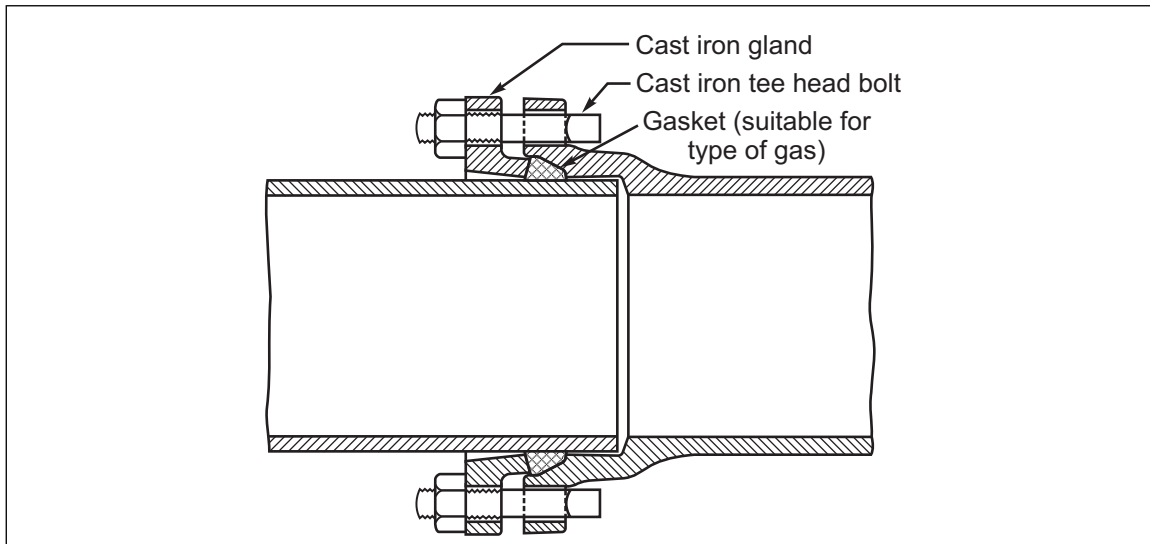

Fig. 2.1.2.2-1. Standardized mechanical joint for cast iron pipe.

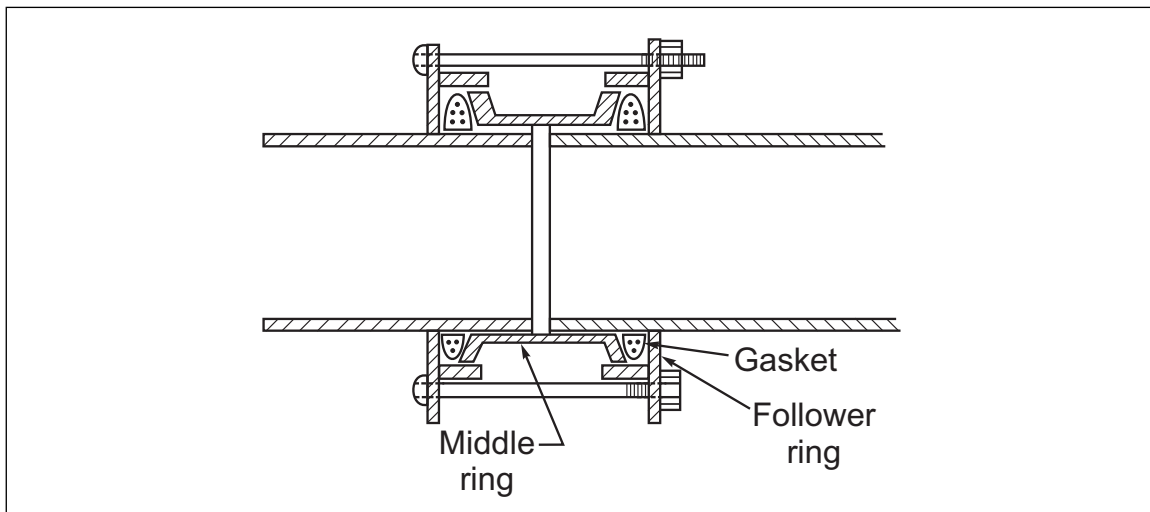

Fig. 2.1.2.4-1. Dresser coupling.

(2.8 m³) of natural gas. Nonferrous metal pipe joints may be brazed with material having a melting point in excess of 1000°F (537°C). Flared joints and fittings may be used. Copper pipe with wall thickness equivalent to Schedule 40 steel pipe may be threaded and used for connecting screwed fittings or valves.

2.1.2.6 Aluminum alloy pipe and tubing (alloy 5456 prohibited) should be coated when in contact with plaster, masonry or insulation or subject to repeated wetting by such liquids as water, detergents or sewage. It should not be used in exterior locations or underground.

2.1.2.7 Corrugated stainless steel conduit should be tested for conformance with the requirements for internal pipe systems, such as AGA 1-87, *Requirements for Interior Piping Systems Using Corrugated Stainless Steel Conduit*.

2.1.2.8 Plastic pipe, tubing and fitting materials and connecting methods should be applied as provided in the ANSI Z223.1/NFPA 54-2015 *National Fuel Gas Code*; and as specified by the authority having jurisdiction. Plastic pipe may be used only for underground use and not over 100 psig (689 kPa, 6.9 bar) design pressure. Fittings should be joined by solvent cement, adhesives, heat fusion or compression couplings. Threaded joints should not be used. When a compression joint is used, gaskets should be compatible with the piping and the gas. Use an internal tubular stiffener with the fitting.

2.2 Equipment and Processes

2.2.1 Earthquake Protection

Apply the following recommendations for gas lines in active seismic areas, FM 50-year through 500-year earthquake zones: (See Data Sheet 1-2, *Earthquakes*.)

2.2.1.1 Cast iron should not be used for valves, fittings, or supports.

2.2.1.2 Shock-operated valves should be strategically located in the piping system. These valves are designed to close from a sufficient force of an explosion or earthquake. They are available either as inertially activated ball check valves or as solenoid-, air- or spring-activated valves triggered by shock switches. Periodic maintenance is necessary.

2.2.1.3 Threaded pipe should not be used. Welded piping systems can withstand the cyclic, horizontal, vertical and rotational forces of an earthquake much better than threaded piping, which may fail after several cycles.

2.2.1.4 Clearance should be provided where piping passes through foundations, walls, and floors. If one part of the piping is secured rigidly and the other is free to move, sway bracing should be provided.

2.2.1.5 Hangers with shock absorbing devices of an Factory Mutual Research Approved design should be provided for piping subjected to seismic forces imposed by other equipment. Tags should be attached to piping having springs so that the hangers can be reset to their proper tension.

2.2.1.6 Flexible couplings should not be used. Experience has shown that they are susceptible to leakage.

2.2.1.7 Transmission piping should not cross at right angles to known earthquake faults. Crossing at an oblique angle allows for lateral movement and reduces the possibility of pipe shearing.

2.2.1.8 Heavy equipment that uses gas (e.g., boilers, ovens, etc.) should be adequately anchored to prevent excessive movement.

2.2.1.9 Emergency procedures and training programs should be established. The procedures should include instructions to shut off gas supplies and gas using equipment. Educate the persons responsible for emergency action with regards to the nature, probable maximum intensity, and duration of earthquakes, and the expected response of buildings and equipment. Familiarity with these aspects may reduce confusion. Periodic earthquake drills should be conducted to condition plant emergency organization members. They should also be trained to handle the emergency completely and not expect outside help.

2.2.2 Corrosion Protection

2.2.2.1 Cover all buried pipe on all sides with at least 6 in. (0.15 m) of compacted sand or noncorrosive, stone-free earth, followed by at least 2 ft (0.61 m) of well-tamped noncorrosive backfill having no large stones.

2.2.2.2 Protect buried steel pipe against corrosion by shop- or field-applied wrapping and coating. A typical satisfactory coating consists of one coat of primer, two 1/32 in. (0.79 mm) thick coats of bituminous enamel, one layer of mineral felt, and a final layer of Kraft paper. Cathodic protection is an acceptable alternative. If there is reliable evidence that the soil is not corrosive, coating with a suitable paint may be acceptable.

2.2.2.3 To prevent harmful galvanic action where underground copper piping is connected to steel piping, install an insulating coupling or flange between them, or protect the copper and steel for at least 2 ft (0.61 m) from the junction with insulating corrosion protection material.

2.2.2.4 Where exposed to excessively corrosive conditions, as for example, pipes passing through a wet concrete floor, install a floor sleeve and pack the space between pipe and side (Fig. 2.2.2.4-1). Color-code to identify the gas piping in accordance with ANSI 13.1, *Scheme for the Identification of Piping Systems*.

2.2.2.5 Ensure steel service piping in a crawlspace has an unbroken, wrapped, corrosion-resistant covering for its full length equal to that used with outdoor steel pipe. The protective coating must be applied or restored to good condition after the gas pipe is given the necessary bends.

2.2.3 Buried Pipe

In addition to the recommended precautions for corrosion protection, apply the following recommendations for buried pipe:

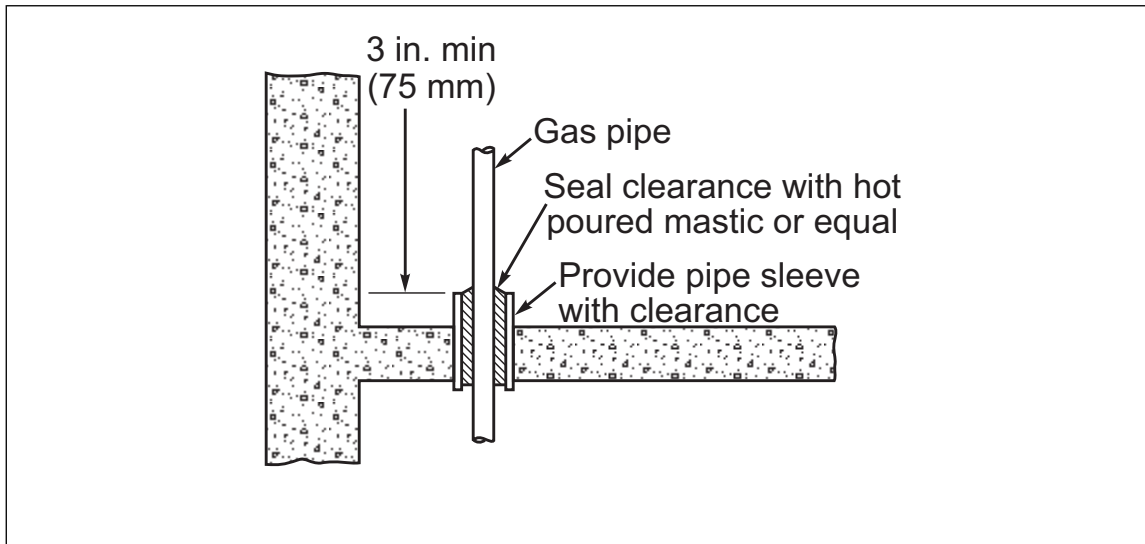

Fig. 2.2.2.4-1. Sealing pipe passing through wet floor.

2.2.3.1 Provide firm supports for steel pipes laid in ground where the soil is of low load-bearing quality, as in filled or marshy ground. In areas subject to localized or general settling, it may be necessary to provide a continuous reinforced concrete base supported on piling or reinforced concrete beam supported on the foundation walls. Do not install cast iron pipe in such soils.

2.2.3.2 Dig pipe trenches to accurate grade. Ensure pitch is accurate if gas has condensate.

2.2.3.3 Locate all buried pipe joints such as welds at least 10 ft (3 m) from wall entrances or any other points where the pipe may be rigidly held against ground movement.

2.2.3.4 Ensure buried drip pots have short inlet and outlet-pipe stubs carefully welded to the body and connected to the service pipe by Dresser couplings. Locate drip pots so they cannot impose loads on the piping or reduce the flexibility of the buried-pipe system, which enables it to tolerate ground movement without breaking. Use copper tube for condensate drains or blowoffs that rise to grade from buried drip pots. The flexibility of the copper tube will prevent breakage if the tube is run over by heavy vehicles.

2.2.3.5 Protect pipe that runs beneath railroad sidings and roadways carrying heavy vehicles with a vented pipe sleeve.

2.2.4 Building Entrances

2.2.4.1 Arrange buried outdoor gas-service pipe to rise above grade before it enters the building, provided the gas is free of moisture and/or is not subject to freezing. This will provide some protection against the travel of gas leakage along the outside of the buried gas-service piping and through the gas pipe opening in the foundation wall. Provide protection against corrosion and physical damage where the pipe rises aboveground.

2.2.4.2 If a below-grade entrance to a crawlspace is used, provide at least 18 in. (0.46 m) of clear space around the gas pipe inside the foundation wall (Fig. 2.2.4.2-1). The entrance pipe must have a preformed bend and be continuous from the head of service to the first pipe joint located at least 10 ft (3 m) outside the foundation wall.

2.2.4.3 Provide a sleeve with its own protection against corrosion through the foundation wall and extend into the crawlspace at least 2 in. (50 mm) from the foundation wall face and at least 18 in. (0.46 m) outside. Ensure the sleeve is cemented tightly in the foundation wall with cement grout or expanding cement. Also provide a second pipe sleeve extending 2 in. (50 mm) above the floor over the crawlspace. Seal the space between the gas pipe and the wall and floor sleeves with cement grout to prevent passage of gas or water.

2.2.4.4 If a below grade entrance is used to a building having no space below the floor, encase the gas pipe within a sleeve from outside the wall to above the floor (Fig. 2.2.4.4-1). Insert the gas pipe in the protective

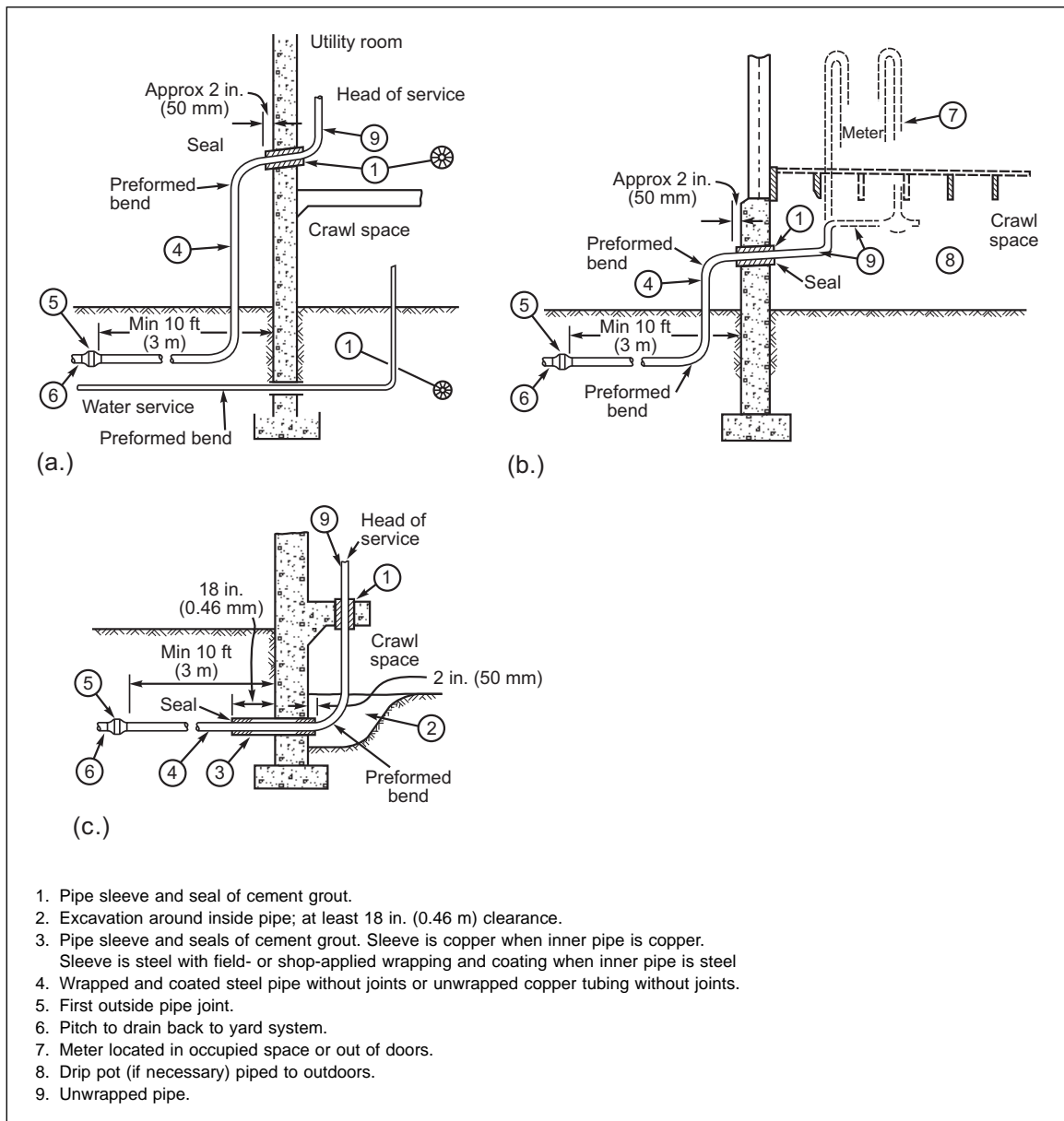

Fig. 2.2.4.2-1. Gas pipe entrance into buildings with crawl or unfrequented basement space. Arrangement (a) is preferred. Use arrangement (b) if impossible to eliminate piping from crawl or unfrequented basement space. Use arrangement (c) when necessary to have a buried gas-service entrance.

pipe with both preformed in one bending operation. Seal the sleeve in the foundation wall and the floor and the space between the protective pipe and the gas pipe tightly with cement grout.

2.2.4.5 Seal openings around all other buried pipes such as electric conduit, sewer, steam, or water with cement grout or asphalt mastic where they enter buildings through walls or floors, and where the openings are within 75 ft (23 m) of buried gas lines.

2.2.5 Indoor Piping

The following recommendations on indoor piping are in addition to those made under 2.1.1, General:

2.2.5.1 Install indoor gas pipe above ground and locate to avoid exposure to physical damage. Whenever possible, keep gas pipe out of crawl or unfrequented basement spaces. Do not install pipe in concealed, inaccessible spaces such as elevator shafts, chutes, air, or ventilation ducts.

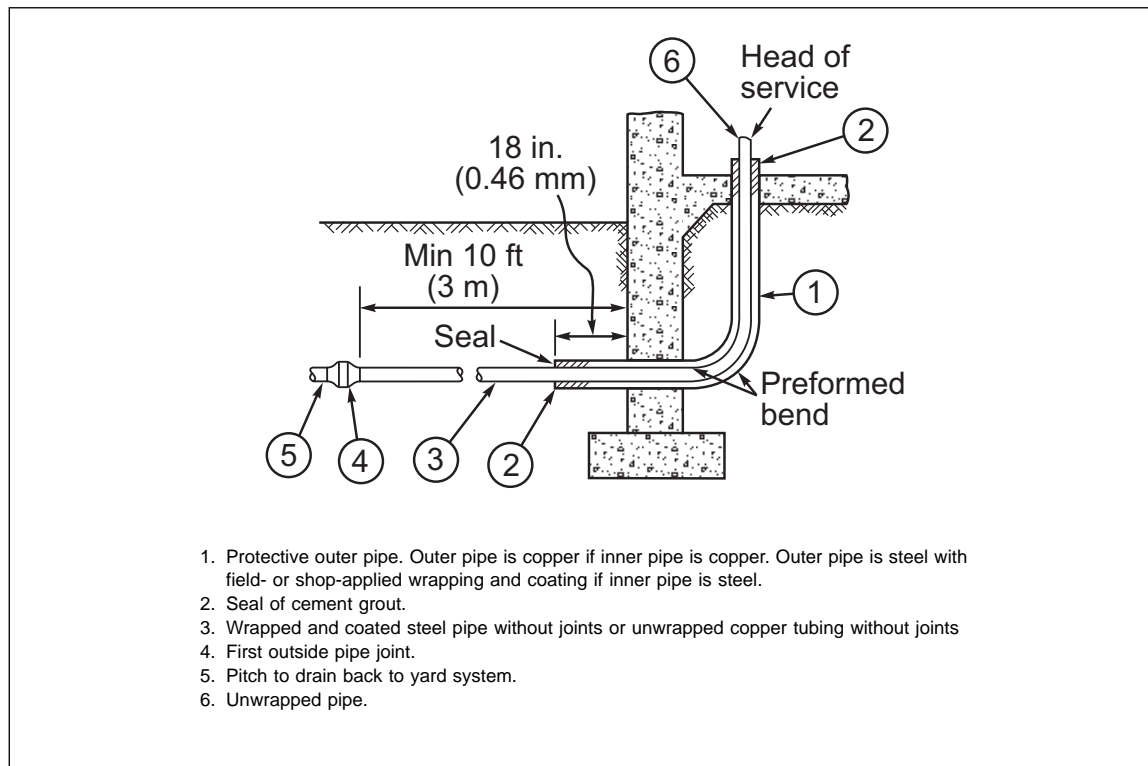

Fig. 2.2.4.4-1. Cased buried gas-service entrance to building with floor slab on grade.

2.2.5.2 Remove existing abandoned piping or have it capped at both ends. When branch piping is abandoned, cut off its connection at the supply line.

2.2.5.3 If pipe under buildings or in concealed, inaccessible spaces is unavoidable, encase in a large pipe. Where a pipe passes underground beneath a building without rising abovegrade, provide a vented casing. Vent all encased piping to a safe location.

2.2.5.4 Ventilate all crawlspaces or unfrequented basement areas (Fig. 2.2.5.4-1). Provide fresh air inlet openings well distributed in all crawlspace exterior walls, located to avoid obstruction and so that they can be readily inspected and kept open. Ensure screens over openings are not less than $\frac{1}{4}$ in. (6.4 mm) mesh. Allow no combustibles in the crawlspace.

2.2.5.5 Provide special inspections and maintenance for piping in buildings with crawlspaces or other unfrequented basement area, especially at multiple-housing units.

2.2.5.6 Use substantial hangers, such as pipe hooks, metal pipe straps, bands or hangers suitable for the size of pipe and of such strength and quality that piping cannot be moved accidentally. Locate hangers to maintain proper grade. Spacing of hangers should not exceed: 6 ft (1.8 m) for $\frac{1}{2}$ in. (12.5 mm); 8 ft (2.4 m) for $\frac{3}{4}$ or 1 in. (19 or 25 mm); 10 ft (3 m) for 1- $\frac{1}{4}$ in. (31.8 mm) or larger; or the distance between floor levels for vertical pipe, 1- $\frac{1}{4}$ in. (32 mm) or larger.

2.2.6 Equipment Valves

2.2.6.1 Lubricated plug cocks, iron-bodied brass-plug gas cocks, and gate, ball, and globe valves meeting specifications for the service intended may be used for controlling the flow of gas in pipes. Ensure valves for steel pipe have ends that are flanged or suitable for welding. With copper pipe having a wall thickness equivalent to Schedule 40 steel pipe, valves may have either screwed ends or ends suitable for brazing. With other copper pipe, ensure valve ends are suitable for brazing only. With ductile cast iron pipe, valve ends must be suitable for standardized mechanical joints.

2.2.6.2 For interconnections between natural gas and liquefied petroleum gas lines, provide a positive means of preventing one gas from entering the piping system of the other gas (Fig. 2.2.6.2-1).

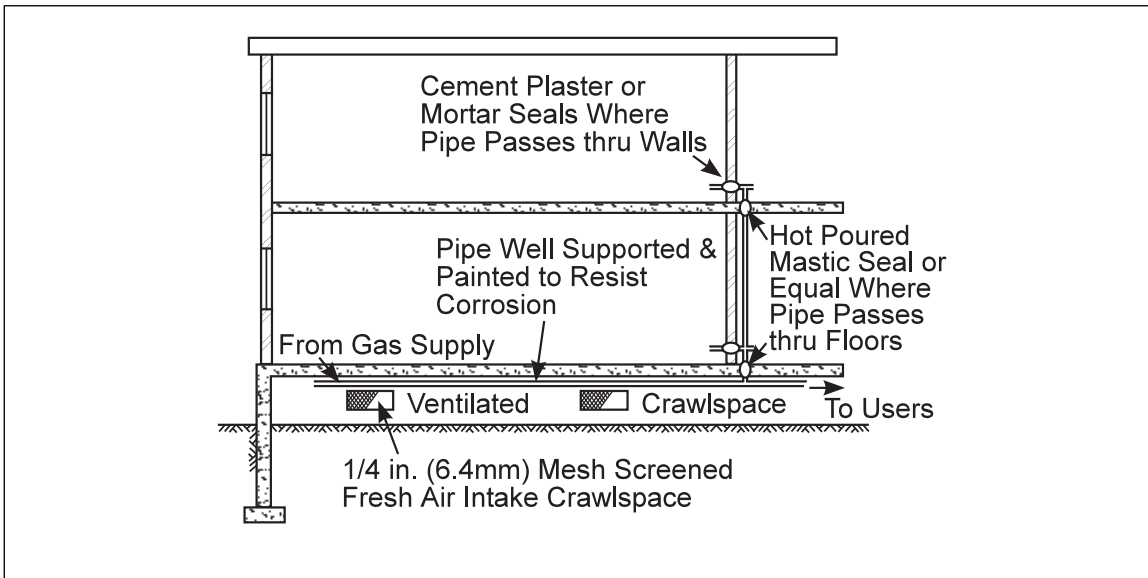

Fig. 2.2.5.4-1. Ventilation of crawspace containing gas piping.

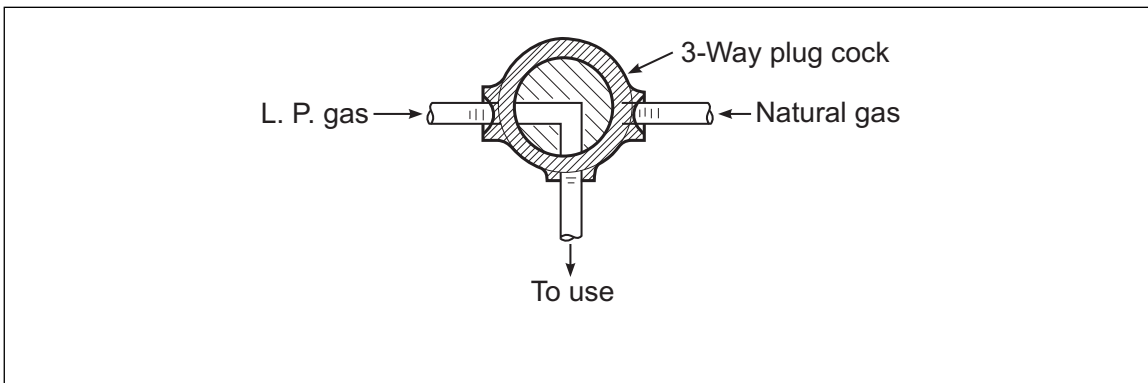

Fig. 2.2.6.2-1. Recommended interconnection arrangement for natural gas and LP-gas.

2.2.7 Meters

2.2.7.1 Locate meters safely. Avoid locating them in crawlspaces or small unventilated areas. Do not install where exposed to corrosion or physical damage. Install large high-pressure meters in detached meter houses. If installed in a small cut-off room in a main building, provide natural ventilation, with electrical equipment suitable for Class I, Group D, Division 1 locations. (See Data Sheet 5-1, *Electrical Equipment in Hazardous Locations*.)

2.2.7.2 Protect meters against overpressure. If the supply pressure serving a gas meter is above the desired outlet pressure, a pressure regulator is used. If the supply pressure is above the rated pressure for the meter, protect it against overpressure by a second pressure regulator installed in series with the first, or a relief valve or FM Approved high-pressure automatic emergency shutoff valve. Pipe regulator or relief valve vents to out-of-doors, using pipe of adequate size. If the meter pressure rating is not known, consult the local utility.

2.2.7.3 Provide vacuum protection for meters designed for less than 5 psi (34 kPa, 0.34 bar) working pressure. Provide a vacuum relief valve between a gas compressor or booster pump and the meter to automatically stop the pump motor and prevent the meter from collapsing if the pump can produce a vacuum exceeding 0.75 psi (5.17 kPa, 52 mb) (Fig. 2.2.7.3-1).

2.2.7.4 Back-pressure protection is needed if air or oxygen pressure exceeds the gas pressure, or if gas from a high-pressure system may back up through the compressor. Install a back-pressure check valve

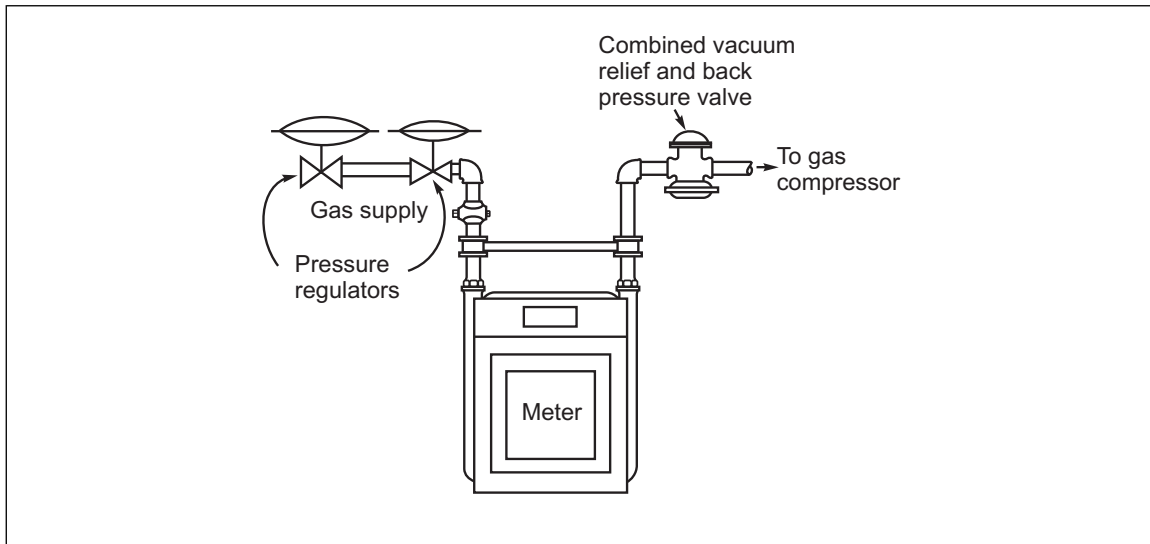

Fig. 2.2.7.3-1. Protecting meters against overpressure.

downstream of the meter if mixing introduces the hazard of accidental reverse flow (Fig. 9). Back-pressure protection may be combined with vacuum protection in a single unit (Fig. 2.2.7.4-1).

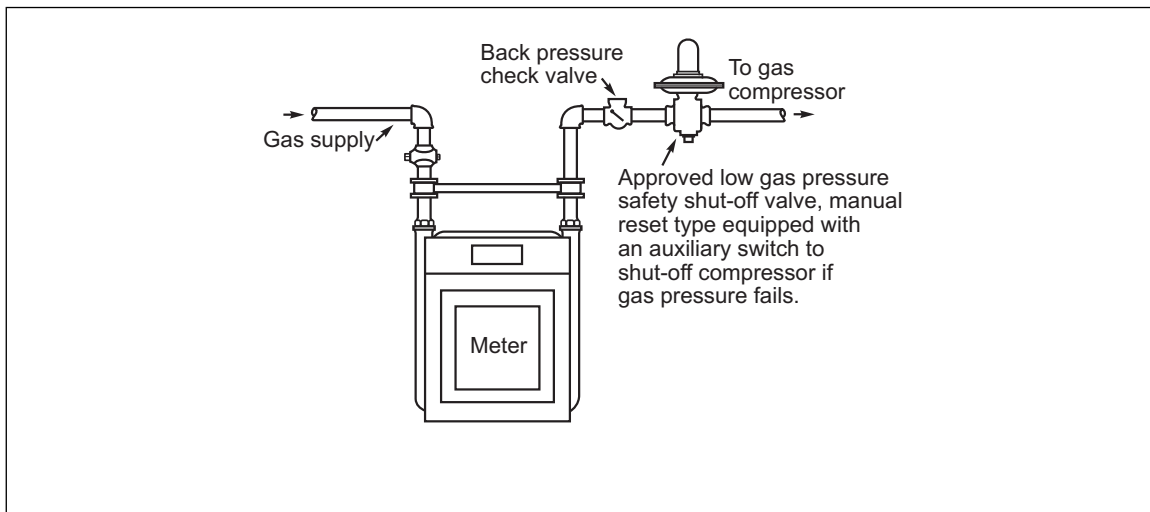

Fig. 2.2.7.4-1. Protecting meters against back pressure.

2.2.8 Pressure Regulators

2.2.8.1 Locate pressure regulators safely, as described for meters.

2.2.8.2 Provide overpressure protection for pressure regulators. If the gas pressure upstream of a regulator is above safe pressure for the equipment serviced, provide protection against overpressures by installing a second pressure regulator in series with the first, or a relief valve or FM Approved high-pressure automatic emergency shutoff valve. The first regulator may leak.

2.2.8.3 Vent the regulators. Except for vents of zero, governors used in connection with air-gas mixers or small regulators in large well-ventilated industrial areas where explosive concentrations of gas would not accumulate, atmospheric chamber vents of gas pressure regulators should be piped out-of-doors or to a location adjacent to a constant-burning pilot (Fig. 2.2.8.3-1).

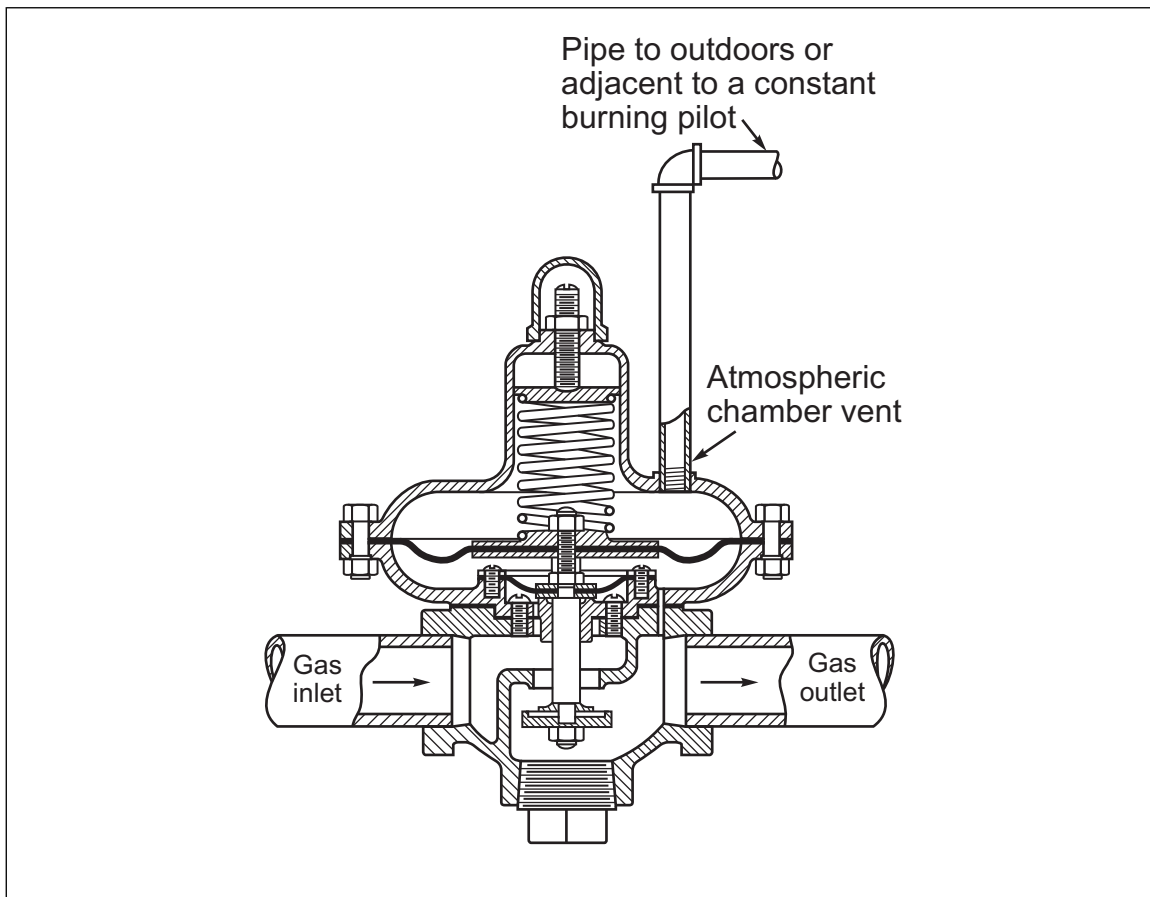

Fig. 2.2.8.3-1. Venting pressure regulators.

2.2.8.4 Small regulators (listed in ANSI 221.18, *Gas Appliance Pressure Regulators*) may be provided with a vent-limiting means that will limit the release of gas upon diaphragm rupture to no more than 2.5 ft³ per hour (0.071 m³/hr) of 0.6 specific gravity gas. These may be used without venting to out-of-doors.

2.2.9 Gas Wells

2.2.9.1 Locate wells about 400 ft (122 m) from important buildings. If adequate space separation cannot be provided, one of the following should be provided:

- a) Gas detection system at the well head site connected to a constantly attended location
- b) Storage tanks of weighting material (“mud”) with a manually starting pump that injects the material into the well to cap gas flow
- c) An automatic valve that caps the well in case of a blowdown (called a “down hole valve”)

In no case should a well be located less than 200 ft (61 m) from important buildings.

2.2.9.2 Install a blow-out preventer of sufficient size and working pressure rating to control normal hydrostatic pressure for the deepest pool to be penetrated on the drill casing. The preventer must be capable of closing off the casing when the drill pipe is not in the hole.

2.2.9.3 Notify the fire service before drilling commences.

2.2.9.4 Do not allow ignition sources within 100 ft (30 m) of the drilling.

2.2.9.5 Provide FM Approved 20-lb (9 kg) dry chemical extinguishers at strategic locations on the derrick floor.

2.2.9.6 Fence in the well to prevent mechanical damage and unauthorized valve operation.

2.2.10 High Pressure Gas Transmission Lines

High pressure pipe lines usually are operated with pressures of 250 psi to 1100 psi (1.7 MPA to 7.6 MPA, 17.3 bar to 75.9 bar). The following suggestions can help minimize damage.

2.2.10.1 Do not build over transmission lines. Locate proposed buildings at least 500 ft (150 m) from pipelines.

2.2.10.2 If a pipeline is close to an important building(s), encase the pipe within a larger pipe that is vented at least 300 ft (91 m) from the building. If this is not practical, brick up any windows facing the pipeline. If the walls facing the exposure are combustible, face them with a 2-hour rated noncombustible material.

2.2.11 Low Pressure Gas Holders

2.2.11.1 Locate low-pressure holders out-of-doors and at least 25 ft (7.6 m) from important buildings.

2.2.11.2 Provide inspection and maintenance to ensure that bell-travel guides do not bind and that the heating system for water seal and tank holds water temperature above 40°F (4°C).

2.2.11.3 Ensure the holder bell is visible through the compressor room window, or provide some other means for checking the height of the bell if a compressor takes suction from the gas holder. Provide travel limit switches to stop the compressor when the bell is still a safe distance from its lowest position to prevent collapsing the bell or drawing in air through holder seals.

2.2.12 Waterless Holders

2.2.12.1 Locate waterless holders out-of-doors and at least 25 ft (7.6 m) from important buildings.

2.2.12.2 Provide careful maintenance and natural ventilation to prevent a dangerous accumulation of explosive mixture in any space above the piston.

2.2.12.3 Provide automatic protection against overpressure when the piston reaches the top of its travel, and automatic vacuum protection near the bottom of the piston travel to prevent the gasholder from being completely emptied and collapsed. Ensure the protective devices do not allow air to enter the holder.

2.2.13 Pressure Holders

2.2.13.1 Locate pressure holders containing more than 1,000 standard ft³ (28.3 m³) of gas measured at 14.7 psi (101 kPa, 1 bar) and 32°F (0°C), at least 75 ft (23 m) from important buildings.

2.2.13.2 Ensure holders for pressures over 15 psi (102 kPa, 1.03 bar) are designed, constructed, installed, and operated according to recognized pressure vessel codes, such as the ASME code for unfired pressure vessels, and according to local ordinances.

2.2.13.3 Air or oxygen in pump suction presents a serious explosion hazard. Continuous gas analyzers may be useful for sampling gas delivered to the holder and sounding an alarm or shutting down the compressor if the oxygen content rises above a safe level. The calibration of such continuous analyzers must be checked on a regular schedule by Orsat or equivalent apparatus.

2.2.13.4 Ensure steel for pressure holders have a notched impact strength of 15 ft-lb (20.3 J) for standard Charpy keyhole specimen 0.4 by 0.4 in. (10.2 mm by 10.2 mm) at the minimum outdoor temperature to be expected at the location of the holder. Probable minimum temperatures can be determined from the U.S. National Weather Service records at the nearest station.

2.2.13.5 Ensure welded pressure vessels to contain gas in excess of 15 psi (103 kPa, 1.03 bar) are able to support a full water load and are tested hydrostatically under double maximum working pressure.

2.2.13.6 Ensure piping connected to a pressure holder has sufficient flexibility to prevent transmission of shock or stress to the shell.

2.2.14 Emergency Shutoff Valves

2.2.14.1 Valves controlling gas lines inside a building must be accessible. Clearly mark inside valves and valves controlling distribution mains. Train employees or the emergency response team (ERT) in the location and operation of the shutoff valves.

2.2.15 Compressed Natural Gas (CNG) Trailers and Modules

2.2.15.1 Separate CNG trailers, modules, or decompression equipment from exposures in accordance with Table 2.2.15.1.

Table 2.2.15.1. Separation Between CNG Bulk Storage and or Decompression Equipment and Exposures

Exposure	Release Orifice Nominal Diameter					
	0.75 in. (19 mm)		1.0 in. (25 mm)		1.5 in. (38 mm)	
	ft	m	ft	m	ft	m
Combustible Solids	80	25	80	25	100	30
Combustible Building	80	25	80	25	100	30
Noncombustible Building	50	15	50	15	65	20
Ignitable Liquids Storage	50	15	50	15	65	20
Bulk Flammable Gas Storage	50	15	50	15	65	20
Fire-Resistive Building	35	10	35	10	35	10

2.2.15.2 Where spacing in accordance with Table 2.2.15.1 is not available for a building, use Data Sheet 1-20, *Protection Against Exterior Fire Exposure*, to design exposure protection for exposed buildings.

2.2.15.3 Where spacing in accordance with 2.2.15.1 is not available for ignitable liquid or flammable gas storage, provide water spray protection on the bulk ignitable liquid or flammable gas storage tank(s) in accordance with Data Sheet 4-1N, *Fixed Water Spray Systems for Fire Protection*.

2.3 Operation and Maintenance

2.3.1 Testing

2.3.1.1 Clean, inspect, and test every piping system for gas tightness before placing it in service. Use compressed air or inert gas (never oxygen). Fuel gas may be used on systems operating at ½ psi (3.5 kPa, 0.035 bar) or less. Do not expose valves or their closing mechanism to excessive pressures.

2.3.1.2 Use a test pressure of at least 1.5 times the normal working pressure, but never less than 3 psi (20 kPa, 0.2 bar). When the test pressure exceeds 125 psig, the test pressure must not exceed a value that produces a hoop stress in the piping greater than 50% of the specified minimum yield strength of the pipe.

2.3.1.3 Ensure the system can hold the test pressure for at least ½ hour per 500 ft³ (14.15 m³) of pipe volume. When testing a system less than 10 ft³ (0.28 m³) in volume, the duration of the testing must not be less than 10 minutes. For large systems, i.e., more than 24,000 ft³ (680 m³), the duration need not exceed 24 hours.

2.3.1.4 A soap and water solution or another nonflammable solution may be brushed on joints and at other points to locate leaks. An Approved combustible gas detector may also be used. Do not use an open flame.

2.3.1.5 After the tightness test and before turning gas under pressure into new systems, or after a temporary shutoff, check to ensure that all openings from which gas can escape are closed. For systems with cushion tanks, receivers, large-size pipe, booster pumps, mixers, or other sizable equipment, the explosion hazard from air mixtures will probably be sufficient to require inert-gas purging before admitting fuel gas. Purge the inert gas with fuel gas before placing the pipeline in service.

2.4 Human Element

2.4.1 Emergency Procedures for Gas Leaks or Fires

2.4.1.1 If a gas leak or fire occurs, do the following:

1. Evacuate the building.
2. Notify the fire service.
3. Ventilate the building by opening doors and windows.

4. As far as is practical, eliminate ignition sources. If possible, cut electric circuits at a remote control source. Prevent smoking and open flame.
5. Shut off the gas supply to the area.
6. If the gas is ignited, do not extinguish the fire unless the shutoff valve is located nearby and can first be closed. If the gas line is still under pressure, extinguishing the fire will lead to an accumulation of gas which could result in an explosion.
7. Notify the gas supplier.

3.0 SUPPORT FOR RECOMMENDATIONS

3.1 Description and Hazards of Natural Gas and Gas Piping

Natural gas is widely used in industrial plants, commercial buildings, and housing units. Its use is so commonplace that the leakage hazard from faulty design and improper installation tends to be overlooked. This hazard can be avoided if reasonable precautions are taken.

3.1.1 Explosions from Leaks in Buried Pipe

Leaks in buried gas piping result from corrosion, faulty welds, or mechanical damage. Breaks usually occur at weak spots, such as threaded connections, or welds that embrittle adjacent metal. Soil settlement, thermal expansion, or heavy vehicles usually provide the force needed to break the pipe.

Earth is permeable to gas leakage. Surface-frozen earth and paving act as a barrier, so gas will travel long distances below grade. Leaking gas may travel considerable distances underground by following the pipe or nearby water, steam, sewer, or electric lines. The gas may enter a building through unprotected pipe openings in the foundation wall or floor slab.

Unpaved crawlspaces are particularly hazardous, since the ground may act as a vent for underground leakage. Gas may accumulate undetected in unfrequented and unventilated crawlspaces or leak into buildings where detection could be delayed. Either condition could lead to a severe fire and/or explosion.

3.1.2 Corrosion

External piping corrosion occurs at threaded joints, underground building entrances, contacts between pipe and low resistance conducting material or between piping of dissimilar metals and at coating or pipe defects.

This corrosion is an electrochemical reaction. The differences in piping materials or surrounding materials serve as the electrode. Current flows from the anode to the cathode; in the process, the anode loses material. With pipelines, enough material can be lost to create holes or thin spots in the pipe walls.

Effective corrosion protection can be provided by making the pipeline behave as the cathode (cathodic protection) and/or by effectively insulating the pipe.

There are two methods of providing cathodic protection (Fig. 3.1.2-1). One is to connect the pipeline to a direct current supply, which is usually provided by a rectifier. Anodes placed in the ground near the pipeline receive the direct current and allow the current to flow into the earth. If there are any uninsulated spots on the pipe, the current will flow along the pipe to those spots and to the rectifier. The other method is to place sacrificial magnesium anodes in the ground near the pipeline.

3.1.3 Compressed Natural Gas Trailers and Modules (Virtual Pipeline, Portable Pipeline)

To provide service in facilities where direct natural gas lines are not present, the use of mobile “virtual pipeline” systems are becoming increasingly common. These systems rely on Compressed Natural Gas (CNG) trailers or modules, which are periodically replaced and refilled, to provide continuous natural gas service.

According to manufacturers' literature, the majority of systems operate at 3,600 psi (250-bar) storage pressures, with a maximum hydraulic volume of 1,800 ft³ (50 m³). To protect these systems, pressure relief devices (PRDs) are designed to activate in the event of a fire exposure. In many of these systems, all of the cylinders are tied together into a single upward discharge, where the entire system de-inventories in the event of a fire. Typical exit orifices are approximately 0.75 – 1.5 in. (20-40 mm) in diameter, which is sufficient to fully blowdown the system in a timeframe on the order of 30-60 minutes.

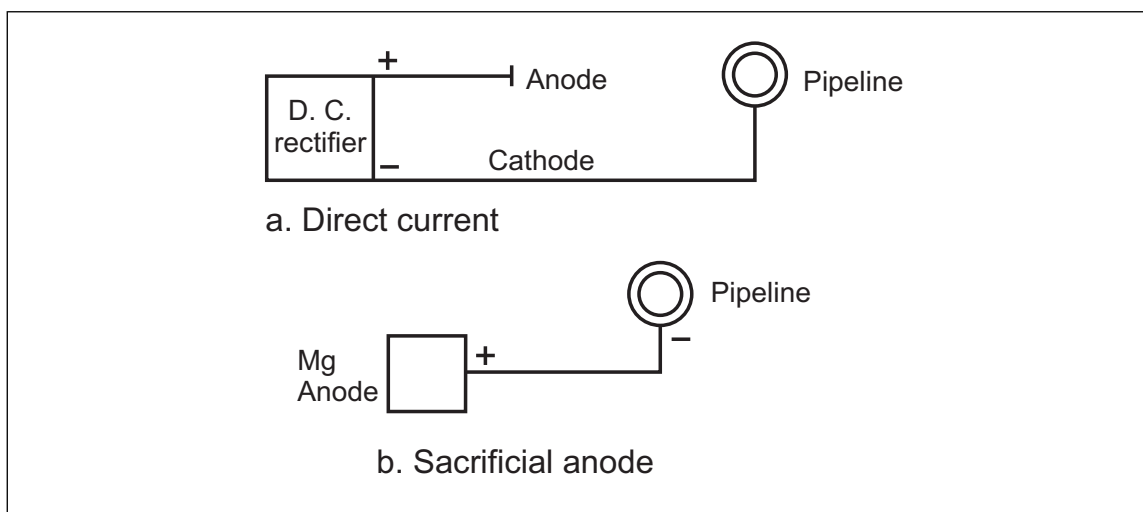

Fig. 3.1.2-1. Two methods of cathodic protection.

The separation distances recommended between CNG trailers or modules and exposures is based on a jet fire resulting from a full-bore release from the PRD. Where the recommended separation distance is provided, the risk of a flammable vapor cloud explosion is minimal due to the lack of congestion.

3.1.4 Natural Gas Wells

In areas where natural gas deposits are relatively close to the surface, wells may be drilled on plant premises. The gas may be used to supplement existing gas supplies. This type of gas well is usually 4000 to 5000 ft (1200 to 1500 m) deep and is drilled with a fluid rotary-type rig. The fluid can be air, natural gas, or “mud” (a special mix of water and chemicals). Debris from the rotary cutting is carried away by the fluid. Mud drilling is the slowest but the least hazardous. The hydrostatic pressure of the mud keeps the gas from escaping. When the proper depth has been reached, concrete is pumped down the well to seal the bottom and fill the space between the well hole and the metal casing that is inserted into the hole. Piping and equipment are installed at the well head and the concrete seal is hydrostatically broken to start the gas flow. Explosives are not normally used in drilling.

Gas pressures at the well head vary from 700 to 1400 psi (4.8 to 9.6 MPa, 48 to 96 bar). An average well produces 200,000 ft³ (5660 m³) of gas per day, although production usually falls off rapidly after several years. If a well is accidentally uncorked, it may produce gas at a rate up to five times as high for 1 or 2 hours before tapering off (called a “blowdown”).

The well head pressure is reduced, and the gas is cleaned, dried, and piped to a nearby gas utility-owned distribution main. Maintenance arrangements include daily or weekly visits by the contractor, who normally retains ownership of the equipment.

When the well is depleted, it is capped and the equipment is removed for possible re-use.

3.1.5 Earthquake

One of the hazards produced by major earthquakes is gas leakage and ignition. Collapsing buildings or ground and equipment movement can rupture or break gas piping. In the resulting confusion, shutting the gas lines may be overlooked. Ignition sources are readily available and gas fires are almost a certainty.

Movement severe enough to break gas piping also may break sprinkler piping and water mains, and cause electric power outages. The number of post-earthquake fires may overwhelm public fire service response. Gas lines in active seismic areas must be properly designed and installed. Ensure emergency precautions and instructions to shut off gas lines and gas-using equipment are posted.

3.1.6 Gasholders

Gasholders are used for reserve storage, to even pressure fluctuations or provide mixing space if the gas supply varies in density and heat content. Because liquefied natural gas systems can store the same amount of gas in a much smaller volume, gasholders are being phased out.

3.1.7 Pressure Holders 1 psi (6.89 kPa, 69 mb) and Over

Extensive damage may result from sudden rupture in pressure holders operating at service pressures up to several hundred psi (0.7 MPa). Rupture may be caused by ignition of accidental air-gas mixtures or structural failure.

3.2 Illustrative Losses

The following loss examples are adjusted to 1990 dollars.

3.2.1 Residential Explosion Caused by Separated Gas Line

A residence was damaged by an explosion resulting from a separated connection between the plastic service line and the compression fitting on the steel riser to the meter. Excavation several weeks earlier for sewers apparently had not been securely backfilled. March 1988; reported by the U.S. Department of Transportation, Office of Pipeline Safety (U.S. DOT, OPS).

3.2.2 Corroded Gas Main Fails

A 2 inch (50.8 mm) steel main had corroded about 15 ft (4.6 m) outside of a Texas motel. A leak survey about three months earlier had not detected any leakage, nor had any complaints of odor been received prior to the explosion. Testing after the accident, which seriously damaged the motel, revealed gas in the soil beneath the motel's paved area. The cathodic protection installed on the main about one year earlier was determined to be inadequate. (April 1988, reported by U.S. DOT, OPS.)

3.2.3 Cast Iron Gas Pipe Fails

A 4 inch (101.6 mm) cast iron gas main cracked circumferentially, resulting in an explosion and fire at a New Jersey residence. The pipe had weakened because of corrosion and failed due to external forces. Plastic pipe was used to replace the cast iron main. (January 1987, reported by U.S. DOT, OPS.)

4.0 REFERENCES

4.1 FM

Data Sheet 1-2, *Earthquakes*

Data Sheet 1-20, *Protection Against Exterior Fire Exposure*

Data Sheet 4-1N, *Fixed Water Spray Systems for Fire Protection*

Data Sheet 5-1, *Electrical Equipment in Hazardous Locations*

Data Sheet 7-95, *Compressors*

4.2 NFPA Standards

NFPA 54, *National Fuel Gas Code*, 1988.

4.3 Others

AGA 1-87, *Requirements for Interior Piping Systems Using Corrugated Stainless Steel Conduit*.

ANSI 13.1, *Scheme for the Identification of Piping Systems*.

ANSI 221.18, *Gas Appliance Pressure Regulators*.

ANSI Z223.1 — 1988.

ANSI/ASME B31.1, *Power Piping*, 1989.

ANSI/ASME B31.8, *Gas Transmission and Distribution Pipelines*, 1989.

APPENDIX A GLOSSARY OF TERMS

Approved: References to “Approved” in this data sheet means the product and services have satisfied the criteria for FM Approval. Refer to the *Approval Guide* for a complete listing of products and services that are FM Approved.

APPENDIX B DOCUMENT REVISION HISTORY

January 2023. Interim revision. Added recommendations for location of compressed natural gas supply trailers and modules (Section 2.2.15).

January 2020. Interim revision. Minor editorial changes were made.

June 2009. Reference to Data Sheet 7-53, *Liquefied Natural Gas (LNG)*, was deleted.

September 2004. References to FM Global earthquake zones have been modified for consistency with Data Sheet 1-2, *Earthquakes*.

January 2000. This revision of the document has been reorganized to provide a consistent format.

October 1990. Technical Revision.

February 1978. Technical Revision.