

GAS TURBINES

Table of Contents

	Page
1.0 SCOPE	3
1.1 Hazards	3
1.2 Changes	3
2.0 LOSS PREVENTION RECOMMENDATIONS	3
2.1 Introduction	3
2.2 Equipment and Processes	3
2.2.1 Protective Systems	3
2.2.2 Speed Control and Overspeed Protection	4
2.2.3 Inlet Air Systems	5
2.2.4 Fuel Supply and Proof of Flame	5
2.2.5 Condition Monitoring	8
2.2.6 Lube and Seal Oil Systems	9
2.2.7 Bearing Protection	11
2.2.8 Compressor Surge Protection	11
2.2.9 Control Systems	11
2.3 Operation & Maintenance	11
2.3.1 Protection Devices	11
2.3.2 Speed Control and Overspeed Protection System	11
2.3.3 Mechanical-Drive Gas Turbine Overspeed Prevention (Electronic and Mechanical Bolt Type Overspeed Trip Systems)	12
2.3.4 Inlet Air System	12
2.3.5 Fuel Supply System	13
2.3.6 Starting System	15
2.3.7 Condition Monitoring	15
2.3.8 Maintenance	18
2.3.9 Scheduled Inspections	18
2.3.10 Operational Flexibility	21
2.4 Operators	21
2.5 Contingency Planning	22
2.5.1 Equipment Contingency Planning	22
2.6 Alerts	22
3.0 SUPPORT FOR RECOMMENDATIONS	23
3.1 Inlet Air Systems	23
3.2 Fuel Supply System	24
3.2.1 Fuel Shutoff Valve Leakage	24
3.2.2 Fuel Shutoff Valve Leakage Testing	24
3.2.3 Alternative Fuels	25
3.3 Lube Oil System	25
3.3.1 Bearing Types	26
3.3.2 Mechanical System Resiliency	27
3.3.3 Electrical System Resiliency	27
3.3.4 System Design Review	27
3.4 Overspeed Trip System	28
3.5 Exhaust Temperature Control and Protection System	28
3.6 Condition Monitoring	28
3.6.1 Exhaust Gas Temperature Spreads	29



3.6.2 Vibration Monitoring 29

3.6.3 Performance Monitoring 29

3.6.4 Combustor Dynamics Monitoring 29

3.6.5 Lube Oil Testing 29

3.7 Compressor Stall, Surge and Protection 29

3.8 Turbine Wheel Space/Disc-cavity Temperatures 30

3.9 Starting System 30

3.10 Rotor Remaining Useful Life and Service Life Extension Options 30

3.11 Scheduled Inspection, Testing, and Maintenance 31

4.0 REFERENCES 31

 4.1 FM 31

 4.2 Other 32

APPENDIX A GLOSSARY OF TERMS 32

APPENDIX B DOCUMENT REVISION HISTORY 34

**APPENDIX C GUIDELINES FOR AN AUDIT AND INSPECTION PROGRAM FOR ALTERNATIVE
SERVICE PROVIDER (ASP) SERVICES AND COMPONENTS 36**

List of Figures

Fig. 2.2.4.2.1. Double block and bleed configuration 6

Fig. 2.2.4.2.2-1. Triple block and double bleed configuration 6

Fig. 2.2.4.2.2-2. Alternative triple block and double bleed configuration 7

Fig. 2.2.4.4.1. Double block and bleed configuration 8

Fig. 2.2.6.7. Simplified lube-oil system with typical considerations for locked open (LO) and locked
closed (LC) valves 10

Fig. 3.3.1.2. Simplified lube-oil system for a gas turbine with hydrodynamic bearings 26

List of Tables

Table 2.2.1. Alarm and Trip Summary for Protective Systems 4

Table 2.3.1. Recommendations for Testing Emergency Devices 11

1.0 SCOPE

This data sheet provides loss prevention recommendations for gas turbines used to drive generators for electrical power and mechanical equipment such as compressors. It covers aeroderivative and industrial gas turbines, but excludes microturbines.

Industrial applications include but are not limited to; prime movers for processing applications, mechanical drive, marine, and production of power and heat.

For the purposes of this data sheet, the gas turbine assembly includes the following sections: air inlet, compressor, combustion system (may include water injected for NO_x abatement), turbine, and exhaust. The gas turbine also includes protection systems, control and monitoring systems, and associated auxiliary systems.

For fire and explosion protection information, refer to Data Sheet 7-79, *Fire Protection for Gas Turbines and Electric Generators*.

1.1 Hazards

For information on hazards associated with gas turbines, refer to FM Understanding the Hazard (UTH) publication *Combustion Turbines* (P0230).

1.2 Changes

October 2024. Interim revision. Minor editorial changes were made.

2.0 LOSS PREVENTION RECOMMENDATIONS

2.1 Introduction

The recommendations in the following sections are for both aeroderivative and industrial gas turbines unless specifically stated otherwise. While aeroderivative and industrial gas turbine technologies have converged over the years, this data sheet will focus on the specific differences that have a direct impact on loss prevention. These differences include the following:

A. Maintenance of aeroderivative gas turbines is mostly done by changing out the engine (or sections of the engine) and sending it (or them) to a shop for maintenance. Most industrial gas turbines, however, are maintained onsite unless extensive repairs are needed. Some of the smaller ("package") industrial turbines can also be maintained by changing out the unit and sending it to a repair facility for maintenance (refurbishment).

B. Aeroderivative gas turbines use rolling element bearings, while industrial gas turbines typically use hydrodynamic bearings. In some cases, an aeroderivative gas turbine may use hydrodynamic bearings in the power turbine section.

C. The lube-oil systems differ as a result of the types of bearings used. Units provided with rolling element bearings have shaft-driven, positive displacement lube-oil pumps that provide an adequate oil supply for these bearings at various speeds, negating the need for external lube-oil pumps. Units provided with hydrodynamic bearings require lubrication during startup and shutdown and are typically lubricated using ac/dc motor-driven pumps.

D. Aeroderivative gas turbines have multiple shafts. Heavy-duty and most other industrial gas turbines are single-shaft machines. However, some of the smaller industrial gas turbines also have multiple shafts.

2.2 Equipment and Processes

2.2.1 Protective Systems

Provide gas turbines with the alarms and trips listed in Table 2.2.1. For alarm and trip settings, adhere to the original equipment manufacturers (OEM's) recommendations (typically in the operations and maintenance manual or the control specifications).

Table 2.2.1. Alarm and Trip Summary for Protective Systems

Protective System Device, Alarms and Trips	Alarm	Trip
Overspeed trip system:-Single-shaft-Multiple-shaft (each shaft)-Mechanical & electronic	x	x
Rotor thrust / axial position monitoring by axial proximity probes, or temperature in thrust bearing pads (see Note 4)	x	x
Low oil pressure sensor, main lube oil pump, activates standby pump	x	
Low oil-pressure sensor, auxiliary lube-oil pump	x	x
Low oil-pressure sensor, emergency lube- oil pump	x	
Emergency lube oil pump running	x	
High lube oil filter differential pressure	x	
Low oil-level sensor in lube oil tank (See Note 5)	x	x
High oil-level sensor in tank	x	
High oil-temperature sensor, lube-oil header, supply or bearing drains	x	x
Turbine thrust bearing thermocouple, high temperature, metal temperature, and/or drain lube-oil temperature (For existing installations, an operational procedure in place if no trip is provided). (See Note 2)	x	x
Turbine bearing high temperature, thermocouples or embedded RTDs in all Babbitt bearings and/or thermocouple in the roller bearing oil drain lines. (For existing installations, an operational procedure in place if no trip is provided). (see Note 2)	x	x
Roller Bearing Chip Detectors (an operational procedure to immediately shutdown and inspect the source of the chips should be in place)	x	
Vibration monitoring by fixed instrumentation or handheld device (includes a senior operations notification procedure)	x	
High vibration instrumentation on bearings including the gearbox unit, exceeds set point (includes a senior operations notification procedure) (See Note 1)	x	x
High exhaust gas temperature	x	x
High turbine exhaust temperature spread/blade path spread	x	x
High turbine wheel space or disc-cavity temperature monitoring	x	
Compressor bleed valve position error (failure to open on startup and shutdown, failure to remain closed at speed)		x
Inlet guide vane (IGV), variable stator vane (VSV), if equipped, position error/abnormal position feedback to DCS	x	x
Bleed heat anti-icing, if equipped, abnormal position feedback to DCS	x	
Compressor Surge Protection (See Note 5)		x
Dry Low NO _x flash back temperature	x	
High pressure differential across inlet air filter (run-back potential, if equipped)	x	
Combustion flame monitoring/flame-out protection		x
Over and under fuel pressure protection		x
Air intake structure implosion protection	x	
Dry Low NO _x combustion dynamics	x	x
Hydraulic pressure low, auxiliary power unit for valve actuation		x
DC emergency lube oil pump motor thermal overload	x	

Note 1. Trip is based on absolute (casing) radial vibration.

Note 2. This recommendation is for turbines with hydrodynamic bearings (may include aeroderivative power turbines). A unit trip may be warranted depending on manufacturer specifications regarding bearing metal temperature limitations.

Note 3. May be necessary due to bearing metal temperature limitations, notably on exhaust end bearings.

Note 4. This recommendation is for turbines with hydrodynamic (sliding) bearings. A unit trip may be warranted depending on manufacturer specifications regarding operating clearance limitations.

Note 5. Common for new state of the art F, G, H, J class gas turbines.

2.2.2 Speed Control and Overspeed Protection

2.2.2.1 Provide a speed-governing system capable of preventing the gas turbine speed from increasing into an overspeed condition when an instantaneous loss of electric, hydraulic, or aerodynamic load occurs.

2.2.2.2 Provide an emergency overspeed protection trip system or device that shuts off fuel to the gas turbine to prevent overspeed if the governing system fails to control the gas turbine speed. Ensure the trip system is independent of the governing system.

2.2.2.3 If the gas turbine has multiple shafts, provide individual overspeed trip protection for each shaft.

2.2.2.4 Electronic Overspeed Protection Systems

2.2.2.4.1 Test the electronic overspeed trip system at least annually, and when repair or maintenance activities have been conducted that may have affected the overspeed system, using a functional or simulated test. A simulated test is satisfactory if it is supplemented by an actual shutdown of the machine using the emergency trip function. The simulated test and the actual shutdown of the machine using the emergency trip function may be done at separate times within an annual period. See Section 2.3.2 for recommended testing guidance.

A functional overspeed test is a functional (fired) test of the overspeed trip system, performed at or below rated overspeed, to verify the system's integrity.

A simulated overspeed test is a test in which the functioning of the overspeed response, signal transmission, and emergency shutoff valve control respond to a simulated overspeed signal. Simulated tests typically do not test the emergency trip device and the fuel shutoff valves. The test can be conducted while the unit is online, without actually overspeeding it.

2.2.2.5 Mechanical Overspeed Protection Systems

2.2.2.5.1 Perform an annual functional (fired) test of the mechanical overspeed trip system at rated overspeed to verify the system's integrity. See Section 2.3.2 for testing guidance.

2.2.2.5.2 If the test is out of tolerance (as specified by the OEM), consider the overspeed test to have failed. Troubleshoot the overspeed system to determine and correct the cause of the failed test. Following that, conduct two additional tests in which the results agree within the tolerance specified by the OEM. Document all test results, including failed tests.

2.2.3 Inlet Air Systems

2.2.3.1 Provide an air inlet filtration system in accordance with the OEM's recommendations for the range of ambient conditions in which the gas turbine will operate.

2.2.3.2 Provide instrumentation to track the pressure differential across the air inlet filter, as well as any supplemental systems, such as evaporative cooling, when equipped.

2.2.3.3 In climates where icing of the inlet system may occur (ambient temperatures below 40°F [5°C]), make provision to prevent ice formation in the inlet system that can result in damage to the compressor airfoils.

2.2.4 Fuel Supply and Proof of Flame

Supply gaseous and liquid fuels to the gas turbine in accordance with the OEM's fuel specification(s) for the unit. Review fuel supply quality at least annually. Provide a fuel treatment system, as required, to maintain fuel quality within OEM fuel specifications, which include fuel properties such as contaminant limits and superheat requirements. Consider shale gas quality, as the distribution origin may be unknown and may adversely affect the combustion dynamics system and overall performance.

2.2.4.1 Proof-of-Flame

2.2.4.1.1 Provide a flame monitoring system interlocked to close the fuel shutoff valves and trip the gas turbine in the event of a failure-to-ignite or flameout during operation.

2.2.4.2 Gaseous Fuels

2.2.4.2.1 For gaseous fuels, do the following:

- A. Provide two fail-closed, automatic shutoff valves in series in the fuel supply line, with proof of closure.
- B. Provide an automatic vent valve (with position indication in the control room) between the two valves (double block and bleed, as shown in Figure 2.2.4.2.1).
- C. Additionally, provide a pressure or flow transmitter downstream of the fuel gas control valve to monitor the proper flow of fuel through the control valve during startup.

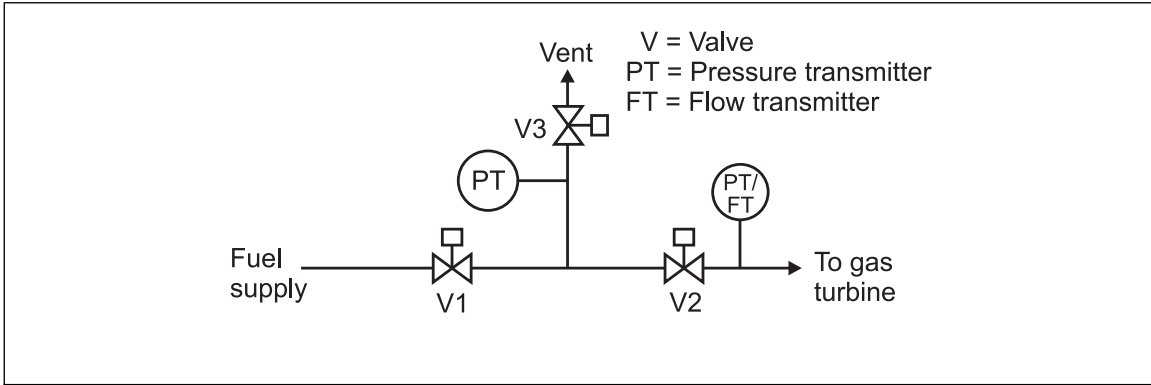

Fig. 2.2.4.2.1. Double block and bleed configuration

2.2.4.2.2 For a unit to qualify for gas turbine purge credit, provide three fail-closed, automatic shutoff valves in series in the fuel supply line, with proof of closure (with position indication in the control room). Provide automatic vent valves between these valves (triple block and double bleed). Two acceptable configurations are shown in Figures 2.2.4.2.2-1 and 2.2.4.2.2-2. Refer to Section 2.3.5 for additional information.

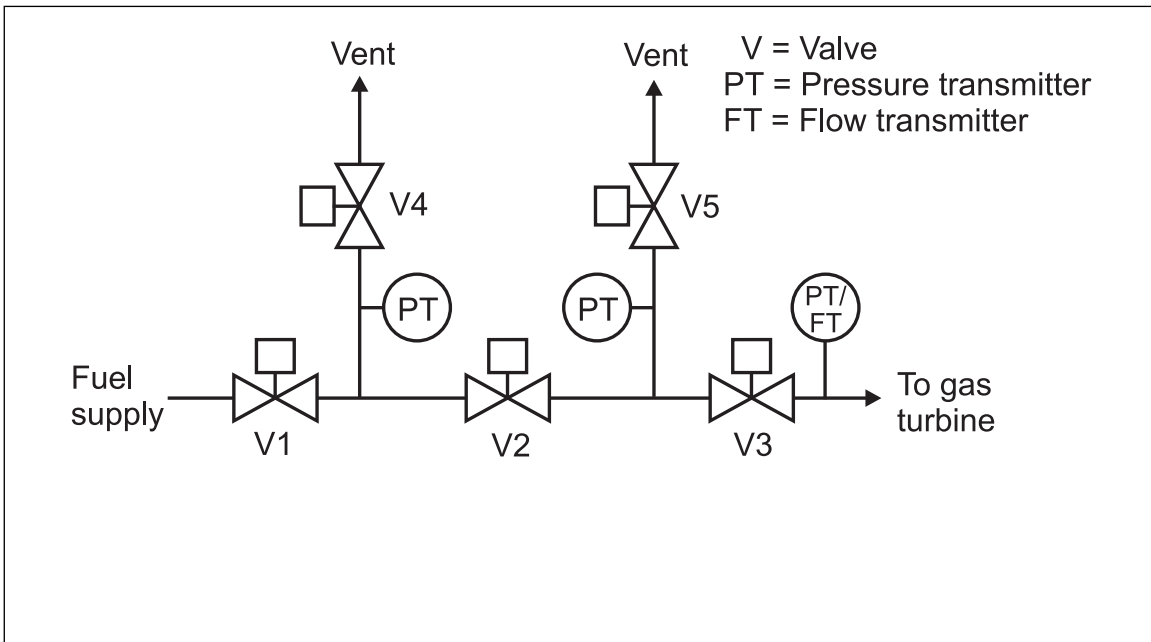

Fig. 2.2.4.2.2-1. Triple block and double bleed configuration

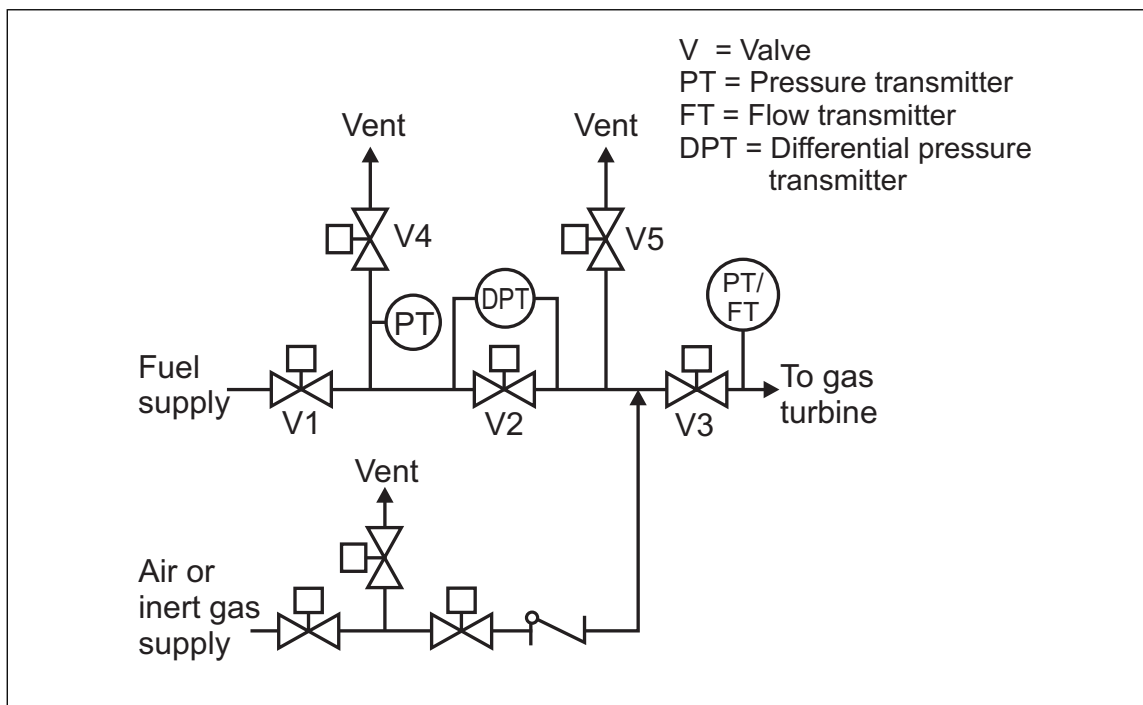

Fig. 2.2.4.2.2-2. Alternative triple block and double bleed configuration

2.2.4.2.3 Use shutoff valves that meet the gas turbine OEM's requirements for closing time and leakage.

2.2.4.2.4 Locate an automatic shutoff valve in a safe location outside the gas turbine enclosure to automatically isolate the fuel supply in case of a dangerous condition.

2.2.4.2.5 Monitor the gaseous fuel properties to ensure the fuel delivered is in accordance with the gas turbine manufacturer's recommendations for the unit. Caution is advised where fuel superheating is incorporated in the supply system for fuel condensation.

2.2.4.3 Fuel Gas System Leakage into Balance-of-Plant Equipment

2.2.4.3.1 Provide safeguards that prevent fuel gas from entering balance-of-plant equipment.

2.2.4.3.2 Where fuel gas is preheated using steam or feedwater from the balance-of-plant (e.g., in combined cycle plants), provide a method to detect fuel gas in the water or condensate line, or water in the fuel line during operation, as applicable. The specific type of leak detection will depend on the design of the heating system, and system parameters such as fuel and water pressure.

2.2.4.3.3 Develop a shutdown procedure to prevent gas migration through the balance of plant in the event a leak is detected prior to shutting the plant down for maintenance. If leak detection is not installed per Section 2.2.4.3.2, follow this shutdown procedure for all maintenance shutdowns (i.e., assume a leak is present whenever a shutdown occurs for the purposes of maintenance activities).

2.2.4.3.4 Prior to performing maintenance on a component that may have had fuel gas collect in it due to leakage, test the atmosphere inside the component for the presence of fuel gas. Use an FM Approved flammable vapor indicator to determine if flammable vapor is present, and purge the equipment of vapor before repairs are made. Route displaced flammable vapor to a safe location. Refer to Data Sheet 7-59, *Inerting and Purging Vessels and Equipment*, for additional information.

2.2.4.4 Liquid Fuels

2.2.4.4.1 Provide two fail-closed, automatic shutoff valves in series in each fuel supply line, with proof of closure. Provide a means to prevent or relieve excess pressure between the two stop valves (e.g., double block and bleed as shown in Figure 2.2.4.4.1).

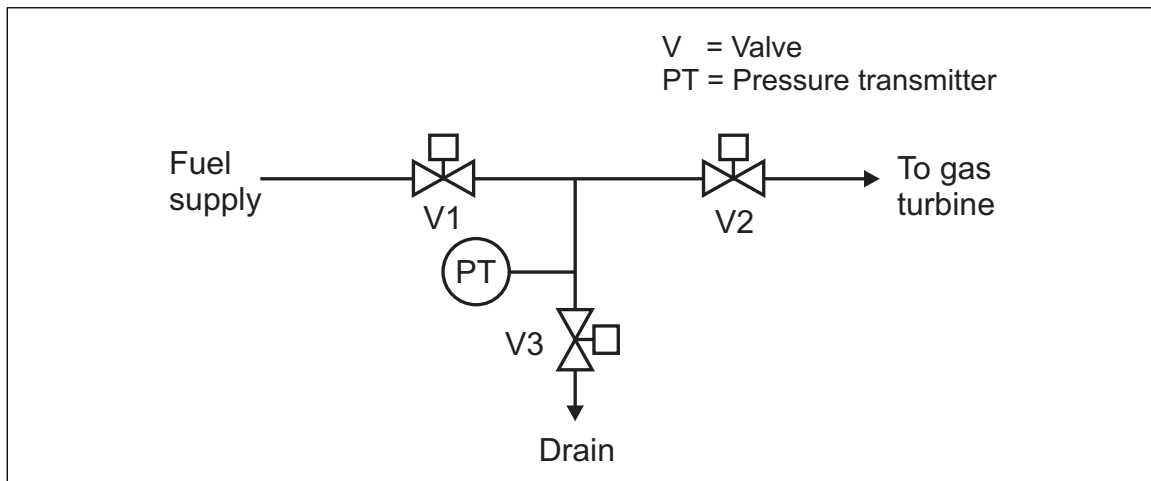

Fig. 2.2.4.4.1. Double block and bleed configuration

2.2.4.4.2 Use shutoff valves that meet the gas turbine OEM's requirements for closing time and leakage.

2.2.4.4.3 Locate an automatic shutoff valve outside the gas turbine enclosure to automatically isolate the fuel supply in case of a dangerous condition.

2.2.4.4.4 Install automatic drains (false start drains) in the lower combustor casings and/or exhaust casing of the gas turbine.

2.2.4.4.5 Monitor the liquid fuel properties to ensure the fuel delivered is in accordance with the gas turbine manufacturer's recommendations for the unit.

2.2.5 Condition Monitoring

2.2.5.1 Provide an exhaust temperature monitoring system downstream in the gas turbine exhaust that measures the temperature from each combustion can or fuel nozzle that will:

- A. Alarm if the exhaust temperature approaches the maximum allowable operating temperature or the maximum allowable temperature spread between combustors.
- B. Trip the unit if the exhaust temperature exceeds the maximum allowable operating temperature or the maximum allowable temperature spread between combustors.
- C. Track peak firing hours and temperatures, when equipped, for trending purposes.

2.2.5.2 Provide a continuous online vibration monitoring system to detect the vibration levels, issue alarms, and shut down (trip) the unit if necessary.

2.2.5.3 If there is a history of combustor instabilities with a particular combustion system design, install a combustion dynamics monitoring and protection system (CDMS) in accordance with the OEM's recommendations. This will aid in the health of the system, warn of potential issues, and forecast tuning needs.

2.2.5.4 Provide adequate measures to monitor and protect against surge conditions, where applicable. See Section 3.0 and Appendix A of this datasheet for more information on Compressor Stall, Surge and Protection, and the section on performance monitoring and surge in Data Sheet 7-95, *Compressors*, for more information on surge descriptions, conditions, protection schemes, and mitigation strategies.

2.2.5.5 Provide continuous online turbine rotor wheel space or disc-cavity temperature alarm for elevated temperatures in the turbine rotor between the turbine blade stages. For OEM designs that do not utilize wheel space or disc cavity temperature monitoring, provide an alternative temperature monitoring solution to monitor the rotor wheel/turbine disc component temperatures.

2.2.6 Lube and Seal Oil Systems

2.2.6.1 Lube and seal oil systems may service either a single component or a train of components. A train of turbomachinery may include components such as a steam turbine, gas turbine, generator, compressors, gearbox, torque converter, SSS-clutch, coupling, etc. If there is a common lube oil and/or seal oil system for these components, ensure the oil and the systems used are compatible with all of the components serviced.

2.2.6.2 Provide a separate source of oil for each train (or component) supplied.

2.2.6.3 Provide an emergency lube oil and seal oil system if it is required to safely shut down the unit if the primary oil supply is interrupted.

2.2.6.4 Ensure the emergency lube oil system configuration is inherently resilient and that no single failure can result in a loss of equipment lubrication. Ensure the emergency oil bypasses coolers and filters and feeds the bearings directly. Evaluate control circuits, electric power and/or piping systems to eliminate single points of failure.

A. When rotating equipment requires lubrication during shutdown and a DC pump is used for emergency shutdown, do the following:

1. To increase the reliability of the lube oil supply, provide separate DC power supply systems, including one separate DC bus for the emergency lube and generator seal oil, and one separate DC bus for the DCS control system uninterrupted power supply (UPS) and the protective relays and circuit breakers.
 - a. Make the auxiliary AC lube oil pump fail-safe (i.e., de-energize to automatically start the auxiliary AC pump on the loss on the loss of DC power).
2. Design the capacity of the battery bank powering the DC lube oil pump such that the battery can supply the DC pump for the duration of the coast-down time of the turbine train, plus 30 additional minutes. Reference Data Sheet 5-28, *DC Battery Systems*, for guidance on system design and sizing considerations. Refer to Appendix A for a definition of "coast-down time."
3. Provide a low-voltage alarm for DC buses at a continuously monitored location. Refer to Datasheet 5-28, *DC Battery Systems*, for more details.
4. Do not wire the DC emergency lube-oil pump motor thermal overload protective devices to trip the motor, only to sound the alarm in an operator-manned control room.
 - a. Recommend that the thermal overload alarms are logged into their maintenance management system as a high priority, so the DC motor can be tested, repaired or replaced as soon as practical.
 - b. In the event of motor thermal overload, allow the DC motor to run to failure, rather than tripping the emergency lube oil pump and damaging the turbine and generator bearings.
5. Provide a DC emergency lube-oil pump starter that is fail-safe (i.e., automatically starts the pump when the AC power, programmable logic controller (PLC), controlling hardware, or communication network is lost).
6. Provide a means for testing the automatic start functionality of the DC lube oil pump. Pressure drop via the pressure-sensing line independent of the lube oil system pressure is the preferred arrangement. Refer to the section on Emergency Lube Oil System Testing for more details.
7. Provide a means (e.g., a check valve) within the normal lube-oil supply line to ensure one-way flow so that under emergency conditions, when the emergency lube-oil pump is operating, the emergency supply cannot be short-circuited back into the lube-oil tank.
8. When the turning gear is not available for normal operation, provide an emergency operating procedure to manually rotate a hot rotor to prevent rotor bowing
9. Recommend adding an alarm to prevent starting the turbine whenever the emergency lube oil pump breaker is not in the "Auto" position.
10. Reference Data Sheet 7-109, *Fuel Fired Thermal Electric Power Generation Facilities*, for recommended startup permissive guidance for lube oil systems.

B. If rotating equipment requires lubrication during shutdown, and an AC or DC lube-oil pump is powered by an internal combustion engine backup generator, ensure the internal combustion engine generator is tested per Data Sheet 7-77, *Testing of Engines and Accessory Equipment*, and maintained per Data Sheet 13-26, *Internal Combustion Engines*, and Data Sheet 5-23, *Design and Protection for Emergency and Standby Power Systems*. Ensure the circuit breaker connecting the internal combustion engine backup generator is left in auto mode when in standby so it can start automatically as intended.

2.2.6.5 Lube-oil temperature is a critical operating parameter and if the machine operates for an extended period of time at elevated temperatures the bearings can be damaged. Provide high lube-oil temperature or bearing metal temperature trips as follows:

A. For a constantly attended unit: Provide an alarm on high lube-oil or bearing metal temperature and have a procedure in place for the operator to respond promptly to diagnose the source of the high temperature. If the high temperature condition cannot be corrected and the oil temperature reaches the design limit, direct the operator to trip the unit, or have the unit automatically trip when the temperature reaches the trip set point.

B. For an unattended unit: If the oil or bearing metal temperature reaches the maximum design set point, have the unit automatically trip.

2.2.6.6 Provide chip detector(s) in either the bearing sumps or the scavenge lines to detect the presence of metallic wear products for units with rolling element bearings.

2.2.6.6.1 Arrange the chip detectors for remote monitoring.

If a chip detector detects the presence of metallic wear products, the gas turbine should be immediately shutdown to investigate and remedy the source of the metallic chips.

2.2.6.7 Where identified and procedurally acceptable, lock open all lube-oil system valves, including impulse lines for instrumentation, which represent single points of failure within the piping arrangement to assist in preventing inadvertent closure. Include valve positions in standard and emergency operating procedures, as well as the respective P&IDs. Refer to Figure 2.2.6.7 for a simplified drawing of how this is applicable under normal operation.

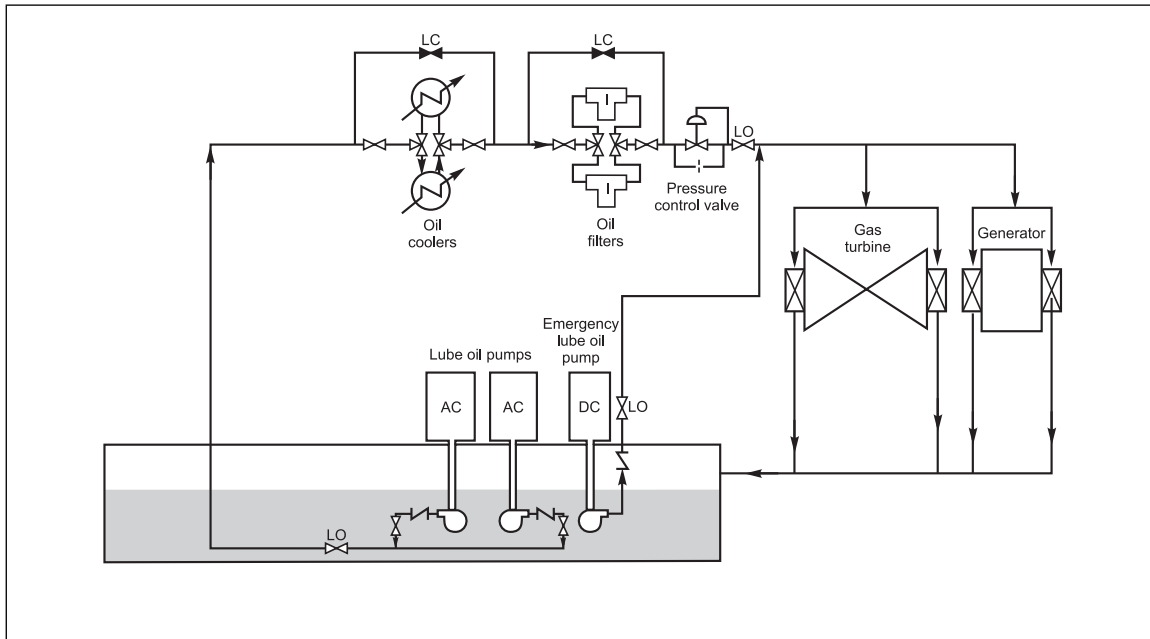

Fig. 2.2.6.7. Simplified lube-oil system with typical considerations for locked open (LO) and locked closed (LC) valves

2.2.7 Bearing Protection

2.2.7.1 Install embedded metal temperature thermocouple detection devices in the Babbitt material of the bearings or temperature thermocouples in the lube-oil drain return lines.

Provide high lube-oil temperature or bearing metal temperature trips as follows:

- A. Install thrust bearing axial displacement monitoring or thrust-bearing pad, high temperature detection, alarm, and trip.
- B. For a constantly attended unit: Provide an alarm on high lube-oil or bearing metal temperature, and have a procedure in place for the operator to respond promptly to diagnose the source of the high temperature. If the high temperature condition cannot be corrected and the oil temperature reaches the design limit, direct the operator to trip the unit; or have the unit automatically trip when the temperature reaches the trip set point.

2.2.7.2. Equip turbine bearings with vibration proximity probes/transducers to monitor the vibration of the rotor relative to the bearing. The measurement of the shaft displacement in two radial directions (X and Y) is used to provide alarm and trip.

- A. Do not provide a remote reset function of vibration trips for remotely operated units.
- B. Use vibration monitoring systems that have self-diagnostic capabilities.

2.2.8 Compressor Surge Protection

2.2.8.1 Provide a fail-safe automatic compressor anti-surge system with two out of three logic to detect abnormal damaging air flow conditions during operation. The specific system required is OEM-dependent. Reference Table 2.2.1, Alarm and Trip Summary for Protective Systems, for guidance on compressor surge protection.

2.2.9 Control Systems

2.2.9.1 Ensure the gas turbine controls meet the recommendations in Data Sheet 7-110, *Industrial Control Systems*.

2.3 Operation & Maintenance

Operate the unit within the limits specified by the OEM. Establish and implement as gas turbine inspection testing and maintenance program. See Data Sheet 9-0, *Asset Integrity*, for guidance on developing an asset integrity program, including quality assurance/quality control (QA/QC) practices and procedures.

2.3.1 Protection Devices

At a minimum, test emergency devices in accordance with the frequencies listed in Table 2.3.1.

Table 2.3.1. Recommendations for Testing Emergency Devices

Test	Frequency
For electronic overspeed protection system, one of the following: - Functional test - Simulated overspeed test plus shutdown by emergency trip (see Section 2.2.2)	Annually
For mechanical overspeed protection system: - Functional test (see Section 2.2.2)	Annually
Actuation of auxiliary and emergency lube-oil pump(s)	Quarterly (Note 1)
Calibration of protective instrumentation: Per Table 2.2.1	Annually (Note 2)

Note 1. Refer to Section to 2.3.7.6 Emergency Lube Oil System Testing, for additional guidance.

Note 2. Follow OEM and/or vendor recommended practices as first priority. Frequencies may vary depending on application, fuel supply, feasibility, and operational profile and mission.

2.3.2 Speed Control and Overspeed Protection System

2.3.2.1 Test the overspeed protection system annually using a functional (fired) or simulated test to verify the system’s integrity.

2.3.2.2 Perform a functional test of the overspeed trip system, at or below rated overspeed, in conjunction with the following events:

- A. During initial commissioning, before first synchronization to the grid
- B. After repair, rework, and/or replacement of any components of the overspeed protection system (forced outage, overhaul, or major inspection) before synchronization to the grid
- C. After repair, rework, and/or replacement of any components of the electronic overspeed protection system

Note: Performing a functional overspeed test for one of the reasons indicated above satisfies the annual functional testing recommendation.

2.3.2.3 After an extended shutdown of three or more months, perform a fired shutdown emergency trip test before loading the unit, to ensure the overall system (hydraulics, solenoids, etc.) have not degraded after months of inactivity.

2.3.2.4 Perform all tests, functional and simulated, in accordance with the OEM's recommendations as part of the asset integrity program.

2.3.2.5 Decrease the turbine load, so the generator circuit breaker (GCB) opens by reverse power. This will ensure that all fuel shut off valves are fully closed. Do not manually open the GCB in any circumstance, because this can lead to an instantaneous overspeed condition if the fuel supply valves are not fully closed.

2.3.2.6 Ensure the testing procedure includes the recording of completed overspeed trip test results, including a section for comments describing any aborted tests or other test difficulties experienced. Ensure operating personnel have documented proficiency in the procedure and control logic.

2.3.2.7 If the test was of the functional type, with the change of trip setpoint speed, include a field in the testing report for verification that the trip setpoint speed was returned to the original value; and this value was checked by a second responsible person.

2.3.2.8 Perform two tests with the maximum speeds within the tolerances specified by the manufacturer. If either test is out of tolerance, consider the overspeed test to have failed. Troubleshoot the overspeed system to determine and correct the cause of the failed test. Conduct one additional test with the tolerances specified by the OEM's instruction book/manual. Document test results, including any failed test(s).

2.3.3 Mechanical-Drive Gas Turbine Overspeed Prevention (Electronic and Mechanical Bolt Type Overspeed Trip Systems)

2.3.3.1 Perform visual and nondestructive fluorescent penetrant inspection (FPI) on the turbine and driven object shaft every 5 years.

2.3.3.2 Perform visual and ultrasonic test on coupling bolts, couplings, driveshaft and gears every 5 years.

2.3.3.3 Inspect coupling and clutches in accordance with Data Sheet 13-18, *Industrial Clutches and Clutch Couplings*. Inspect gears in accordance with Data sheet 13-7, *Gears*.

2.3.3.4 Inspect drive belts and drive chains every 5 years.

2.3.3.5 Inspect speed governor and surge protection system during every major turbine dismantle inspection.

For mechanical-drive gas turbines, a functional test is required after a major overhaul or any repair or replacement of overspeed trip system components, and before the driven equipment is connected.

2.3.4 Inlet Air System

2.3.4.1. Monitor the air inlet system differential pressures and perform inlet filter system maintenance as required and/or in accordance with the gas turbine manufacturer's recommendations. This includes any supplemental systems, such as evaporative cooling, and the age of the associated media. Frequent inspections are recommended due to the potential for deteriorating components based on usage. Methods to inspect these areas could include transparent windows, camera systems, or increased interval of internal inspections (while adhering to full FME protocols).

2.3.4.2. Monitor the quality of the water used in evaporative coolers and ensure the water quality is in accordance with the gas turbine manufacturer's recommendations. Water sourcing, including make-up and

demineralized systems, should be included. Any cross-connection opportunities for water sourcing should be evaluated for contamination; including closed loop, zero-liquid discharge, and makeup systems, as well as single header exposure to affect multiple units.

- A. System resiliency for monitoring and/or alarm detection is recommended to eliminate any single point of failure (e.g., sump level detection, conductivity probe redundancy, water quality sampling).
- B. Independent sampling is recommended prior to putting systems online after layup to mitigate quality concerns. Additionally, winterization or layup procedures should be implemented and adhere to OEM guidelines to maintain a clean and reliable operating environment.
- C. Water flow should be initiated prior to starting each unit and secured only after the unit has stopped rotating to limit ingestion of contaminants.
- D. Out-of-specification parameters require procedure actions and/or operator intervention to limit prolonged operation in this off-normal state. This should include alarm capabilities that notify the control room that an upset condition is occurring.
- E. As-found and as-left flow readings should be recorded for each respective unit daily.
- F. Sump water quality should be sampled daily via grab sample or remote monitoring to detect any deviated conditions and prompt operator actions. Conductivity should be measured independently and compared to the normal system probe reading regularly.
- G. Calibration of all associated monitoring, sampling, or metering equipment should adhere to OEM specifications, or at a minimum annually.

2.3.4.3. Ensure all supporting components to the air inlet system and augmented operations (i.e. foggers, chillers) are in good repair and working order. This may include flow meters, sight glasses, pressure gauges, conductivity probes, level switches, etc., as well as the structure itself (e.g., hardware such as brackets, screws, fasteners, nozzles) to ensure domestic object damage is not of concern.

- A. Post-continuous operation and/or prior to layup from sporadic operations, the GT inlet duct work downstream of the evaporative cooler, including the silencer panels, should be inspected for moisture corrosion, evidence of any evaporative cooler water droplet, or moisture carryover at the earliest opportunity or at a minimum annually.

2.3.5 Fuel Supply System

2.3.5.1 Monitor the quality of the water/steam for power augmentation and NO_x control as part of the combustion system, and ensure the water/steam purity is in accordance with the gas turbine manufacturer's recommendations

2.3.5.2 During the startup sequence, purge the unit in accordance with applicable procedures for the jurisdiction of installation.

2.3.5.3 For gaseous fuel systems designed per Figure 2.2.4.2.1 (double block and bleed), perform a leakage test on the two shutoff valves as follows:

- A. During the shutdown sequence, verify the first shutoff valve (V1) meets the OEM's leakage criteria. If leakage exceeds the OEM's criteria, do not restart the unit until the valve is replaced or refurbished.
- B. During the startup sequence, with airflow passing through the gas turbine, verify the most downstream shutoff valve (V2) meets the OEM's leakage criteria. If leakage exceeds the OEM's criteria, abort the start.

2.3.5.4 Following a gas turbine normal shutdown, purge credit is allowed for the subsequent start provided the gas turbine is fired with gaseous fuel and one of the fuel system configurations described in 2.3.5.4.1 or 2.3.5.4.2 is incorporated.

2.3.5.4.1 Triple-Block and Double-Bleed Configuration

For triple-block and double-bleed configuration do the following:

- A. Provide the following for a gaseous fuel-fired unit to qualify for purge credit using a triple block and double bleed configuration (Figure 2.2.4.2.2-1):
 1. During the shutdown sequence, verify the second shutoff valve (V2) meets the OEM's leakage criteria.

2. While the unit is shut down, continuously monitor both vent line valves to ensure they are open, and the three shutoff valves to ensure they are closed. If continuous monitoring is lost or any valve deviates from its assigned position, purge credit is lost and a subsequent start of the gas turbine requires a unit purge of the gas turbine and downstream components prior to light-off.
3. Continuously monitor pressures in the spaces between the shutoff valves to prove these spaces are not pressurized. If continuous monitoring is lost or either pressure indicates leakage, purge credit is lost and a subsequent start of the gas turbine requires a unit purge prior to light-off.
4. During the startup sequence, with airflow passing through the gas turbine, prove the most downstream shutoff valve (V3) meets the OEM's leakage criteria. If leakage exceeds the OEM's criteria, abort the start.

B. With this configuration, the maximum gas turbine purge credit period allowed is eight days (192 hours). If a unit purge is performed during the eight-day period, the purge credit is reinitiated for an eight-day period. Unit purges can be performed as needed to continue to extend the purge credit period provided the conditions in Section 2.3.5.4.2(A) are satisfied.

2.3.5.4.2 Triple Block, Double Bleed, and Pressurized Pipe Configuration

For Triple Block, Double Bleed, and Pressurized Pipe Configuration do the following:

A. Provide the following for a gaseous fuel-fired unit to qualify for purge credit using a triple block, double bleed, and pressurized pipe configuration (Figure 2.2.4.2.2-2):

1. During the shutdown sequence, prior to pressurizing the piping between valves V2 and V3, verify the second shutoff valve (V2) meets the OEM's leakage criteria.
2. Introduce air or inert gas to create and maintain a pressurized pipe section between the middle and most downstream shutoff valves (V2 and V3).
3. Continuously monitor fuel gas shutoff and vent valve positions. If continuous monitoring is lost or any valve deviates from its assigned position, purge credit is lost and a subsequent start of the gas turbine requires a unit purge prior to light-off.
4. Continuously monitor pressures in the two double block and bleed pipe sections. If the continuous monitoring is lost, or the pressure downstream of the middle shutoff valve falls to within 3 psi (0.2 bar) of the pressure upstream of this valve, purge credit is lost and subsequent start of the gas turbine requires a unit purge.
5. During the startup sequence, with airflow passing through the gas turbine, prove the most downstream shutoff valve (V3) meets the OEM's leakage criteria. If leakage exceeds the OEM's criteria, abort the start.

B. The purge credit period is maintained as long as the conditions in Part A above, Items 2, 3, and 4, are met. The purge credit period is not limited to eight days.

C. Ensure fuel cannot enter the air or inert gas supply line at any time.

2.3.5.5 Inspect the fuel system in accordance with the OEM's recommendations. At a minimum, perform inspections, testing, and maintenance of the fuel system during scheduled dismantle inspections (see Section 2.3.9.5 for additional interval information). As part of this inspection, test fuel shutoff valves for leak tightness.

2.3.5.6 Test automatic drains in the lower combustor casings and/or exhaust casing of the gas turbine annually to ensure they operate properly.

2.3.5.7 Inspect water injection lines for component integrity during operation, as water spray could cause casing distortion and possible blade rubbing.

2.3.5.8 When pursuing a test with alternative fuel or a new plant originally designed to burn alternative fuel, provide additional information on the test plan, additional instrumentation and monitoring and planned system modifications to the control, combustion, fuel delivery, emissions and GT enclosure ventilation/gas detection/fire protection systems.

2.3.5.9 Gas turbines equipped with an alternative fuel system other than natural gas or liquid fuel should follow the OEM guidelines to test fire the system annually, and perform short-term layup strategies to maintain

critical components in good working order and prevent corrosion. See Data Sheet 7-109, *Fuel Fired Thermal Electric Power Generation Facilities*, for additional layout guidance.

2.3.6 Starting System

2.3.6.1 Perform periodic inspection, testing and maintenance of the starting system components in alignment with the gas turbine scheduled outages. A minor inspection should be performed in conjunction with the gas turbine hot gas path outages and a major inspection in conjunction with the gas turbine major outages. Record maintenance performed, include the date of the maintenance checks and detail any equipment defects found or repairs and corrective actions performed.

2.3.6.2 Investigate the starting system configuration for single point failure risks; and depending on the level of component redundancy, determine if long lead time components should be part of an equipment contingency plan. See Data Sheet 9-0, *Asset Integrity*, Section 2.5 for guidance on Equipment Contingency Planning.

2.3.6.3 Refer to the following for detailed inspection, testing and maintenance guidance for starting system prime movers:

- Data Sheet 5-12, *Electric AC Generators*
- Data Sheet 5-17, *Motors and Adjustable Speed Drives*
- Data Sheet 7-95, *Compressors*
- Data Sheet 13-7, *Gears*
- Data Sheet 13-18, *Industrial Clutches and Clutch Couplings*
- Data Sheet 13-26, *Internal Combustion Engines*

Refer to Section 3.9, Starting System, for more information on starting systems

2.3.7 Condition Monitoring

2.3.7.1 Exhaust Temperature Spreads

2.3.7.1.1 Establish a “baseline value” of exhaust temperature spread with which to compare future data. Establish steady state baseline data during initial startup and before and after planned maintenance.

2.3.7.1.2 If monitored values differ from the expected operating parameters, evaluate the trend against the baseline, investigate the cause, and take corrective action as necessary.

2.3.7.2 Turbine Rotor Wheel Space/Disc-cavity temperatures

2.3.7.2.1 Provide an alarm setpoint for protection of rotor high wheel space/disc-cavity temperatures.

2.3.7.3 Vibration Monitoring

2.3.7.3.1 Establish baseline vibration signatures for monitoring and trending equipment performance. Establish new signatures any time an overhaul is performed or if adjustments are made to alignment or balancing.

2.3.7.3.2 If monitored values differ from the expected operating parameters, evaluate the trend against the baseline and investigate. Take corrective action as necessary.

2.3.7.3.3 Calibrate **all** vibration monitoring equipment after every major scheduled outage, but at least annually.

2.3.7.4 Performance Monitoring

2.3.7.4.1 Monitor the overall efficiency of the unit to track performance degradation and to determine when maintenance is required.

2.3.7.4.2 Establish steady-state baseline data at initial startup and before and after planned maintenance.

2.3.7.4.3 Monitor, maintain, calibrate, and overhaul the surge protection system in accordance with the OEM's recommendations. If surge protection performance has degraded, perform maintenance in accordance with the OEM's instructions.

2.3.7.4.4 Based on compressor performance degradation, water wash the compressor in accordance with the OEM's instructions.

2.3.7.5 Lube and Seal Oil System

2.3.7.5.1 Condition Monitoring Program

2.3.7.5.1.1 Establish an effective lube-oil system condition monitoring program that includes written documentation setting forth goals and requirements that are acceptable to the manufacturer for the machine application, operating history, and the risk. The basic elements of an effective lube-oil management, inspection, testing, and maintenance program include, but are not limited to, the following:

- A. Provide purchase specifications with every purchase order for replacement oil.
- B. Store replacement oil in properly identified, sealed containers. To prevent contamination, store oil in a clean, controlled environment.
- C. Sample the replacement oil prior to use to ensure it is the specified oil and not contaminated.
- D. Perform oil reservoir pre-closure inspection and sign-off to prevent debris from entering the oil system following any maintenance work and following refill. Follow OEM recommendations for startup of units as it relates to reservoir cleaning and screen mesh requirements.
- E. Conduct an oil analysis **two to four times annually**, depending on operating conditions and history. Additionally, conduct an analysis prior to outage planning to obtain information pertinent to the outage. Using a qualified lab, and in accordance with ISO standards, analyze oil samples to detect the presence of excess moisture, metallic particles, and contaminants (including varnish if the operating conditions make this a concern). Trend conditions to identify ongoing concerns.
- F. If oil is to be recycled onsite during an outage, adhere to the specifications for the conditioner to be used (e.g., oil type, the purity required, and the contaminants that could reasonably be encountered).
- G. The accumulators on lube-oil, control-oil, and seal-oil lines should be properly charged to prevent pressure shocks and inadvertent trips.

2.3.7.6 Emergency Lube Oil System Testing

2.3.7.6.1 Test the emergency lube-oil pump (ELOP) in accordance with the OEM's instructions, at the following frequencies:

- Quarterly
- After maintenance of the lube-oil pump system or instrumentation
- After any PLC software change, even if not related to the oil system
- No longer than 18 months if only functional testing is performed. Conduct this testing during a plant outage.

The pressure drop test is the preferred method, which is performed by dropping the oil pressure using a three-way valve and an orifice plate.

If a unit is started at least once every quarter and part of the startup procedure is to conduct a functional test of the emergency lube-oil pump, this is an acceptable alternative to quarterly testing. As part of this test, confirm operability of the pump by checking the outlet pressure, motor amperage, or other means as appropriate. Record and trend the results.

2.3.7.6.2 Perform a functional test and calibrate the pressure switches, pressure transmitters and level sensors in the system in accordance with the OEM's instructions but at least annually.

2.3.7.6.3 If a pressurized or gravity rundown tank is used to supply emergency lube-oil, test the tank low-level alarm at least annually.

2.3.7.6.4 For units that will run continuously for longer than the recommended test intervals, ensure the installation makes provision for the components of the emergency lube oil system to be tested while the unit is in operation.

2.3.7.6.5 If a lube oil cooler temperature control valve is used to control oil temperature, test and calibrate the control valve annually to prevent hot oil from bypassing the lube oil coolers and damaging the bearings.

2.3.7.6.6 Reference Data Sheet 5-28, *DC Battery Systems*, for inspection, testing and maintenance practices.

2.3.7.7 Lube-Oil and Seal-Oil System Condition Monitoring Program

2.3.7.7.1 Establish an effective lube-oil system condition monitoring program that includes written documentation setting forth goals and requirements that reflect the equipment's application, operating history, and the risk. The basic elements of an effective lube-oil management, inspection, testing and maintenance program include, but are not limited to the following:

- A. Provide purchase specifications with every purchase order for replacement oil.
- B. Store replacement oil in properly identified, sealed containers. To prevent contamination, store oil in a clean, controlled environment.
- C. Sample the replacement oil prior to use to ensure it is the specified oil and not contaminated.
- D. Perform oil reservoir pre-closure inspection and sign-off to prevent debris from entering the oil system following any maintenance work and following refill. Follow OEM recommendations for unit startup as it relates to reservoir cleaning and screen mesh requirements.
- E. Perform oil analysis according to the recommendations of the OEM regarding frequencies, point of sampling and reference values for each parameter.
- F. Sampling frequency: Start with quarterly analysis. The frequency might be decreased to every six months if good and continuous conditions are observed and trended. Additionally, conduct an analysis prior to outage planning to identify any adverse conditions that can be rectified during the outage.
- G. Use a qualified lab, and in accordance with ISO standards, have oil samples analyzed to detect the presence of excess moisture, metallic particles, and contaminants (including varnish if the operating conditions make this a concern). Trend conditions to identify ongoing concerns.
- H. Trend all parameters, search for any parameters with a tendency to deviate from the reference values and plan accordingly to address the situation. Consult with the OEM or a reputable contractor for guidance. White metal (babbitt) components might indicate wear at bearings. A high varnish potential indicates varnish is forming in the oil.
- I. If oil is to be recycled onsite during an outage, adhere to the specifications for the conditioner to be used (e.g., oil type, the purity required, and the contaminants that could reasonably be encountered).
- J. Ensure the oil sampling points are representative of the oil in the entire system. Have oil samples taken at the bearing oil return lines or drains. Unless recommended by the OEM, do not collect samples in points downstream of the oil filters and upstream of the bearings because those locations may not identify impurities in the oil tank or at the bearing pedestal oil sumps.
- K. For an oil-purification system using a centrifuge, ensure two additional samples are taken every two weeks. These samples are from the inlet and outlet sampling ports on the centrifuge itself. The intent of these samples is to help determine when the centrifuge needs cleaning and its effectiveness.

2.3.7.8 Compressor Surge Protection

2.3.7.8.1 Inspect, refurbish and calibrate the compressor surge protection system components and instrumentation as necessary but at least every turbine major dismantle outage. Refurbish or replace parts as necessary.

2.3.8 Maintenance

The primary scope of the maintenance effort includes the following:

- The gas turbine and its components
- Controls and accessories (including air inlet system)
- Interfaces with driven equipment

2.3.8.1 Ensure the gas turbine and its components are inspected, tested, and maintained in accordance with the OEM's recommended practices, typically included in the turbine operation and maintenance manuals with supplementary material provided via technical alerts (e.g., service bulletins and technical information letters) as part of the asset integrity program.

2.3.8.2 Ensure all OEM technical alerts have been or are being addressed in a timely manner (also see Section 2.6).

2.3.8.2.1 When an alternative service provider's gas turbine services or components are being (or have been) procured, have an audit and inspection (A&I) program in place to ensure quality components and services are procured. At a minimum, ensure the A&I program addresses the items listed in Data Sheet 9-0, *Asset Integrity*, as is appropriate for the services or components being procured.

2.3.8.2.2 Recommended inspection intervals are based on usage and do not consider the actual operating conditions for a specific unit. The intervals are affected by cyclic operation (starts and trips), load, firing temperature, fuel (type and quality), steam/water injection (amount and quality), and site environmental conditions. Conduct a review of these intervals if/when there is a change in operational profile or regime. Go to Section 3.10 for examples of how these intervals are calculated.

The method of determining the recommended inspection intervals differs for each OEM and class of machine. The following are typical methods of determining recommended inspection intervals:

- equivalent hours and equivalent starts (whichever is limiting)
- factored hours and factored starts (whichever is limiting)
- equivalent operating hours; a combination of hours and starts (each start is converted to an equivalent number of operating hours [EOH])
- fired hours (for aeroderivatives)

2.3.8.2.3 Implement a robust foreign material exclusion program during all maintenance and inspection activities. For further guidance on foreign material exclusion, see Data Sheet 9-0, *Asset Integrity*.

2.3.9 Scheduled Inspections

Provide the following types of inspections for each unit.

2.3.9.1 Initial Inspection

Perform an initial visual borescope inspection of the unit in accordance with the OEM's recommendation. This first inspection is done prior to the normal maintenance inspection interval to evaluate initial startup issues.

2.3.9.2 Running Inspection

Running inspections consist of monitoring operating conditions and local walkdown inspections of the equipment while the unit is operating. For additional information see Section 2.2.5.

2.3.9.3 Borescope Inspection

Borescope inspections are an effective method used to monitor the condition of internal components without removing the casing. Perform borescope inspections in accordance with OEM recommendations, but at least annually. The OEM's recommendations and target intervals are typically found in the operation and maintenance manual, service bulletins, or technical information letters. These target intervals are established based on average unit operating modes and may be adjusted in accordance with actual operating experience,

mode of operation, the fuels used, and the results of previous borescope inspections. Frequency of these inspections should be reevaluated with the manufacturer if the unit(s) experience a change in operational profile.

2.3.9.4 Inspection of Externals

2.3.9.4.1 During borescope and similar inspections, verify the condition of the upstream components, including all systems from the filter house to the compressor inlet. At a minimum, do the following:

- A. Inspect inlet air systems, and dirty and clean air sections, for corrosion, cracked silencers, damaged, or cracked expansion joints, and loose parts such as the nozzles for water wash, fogging, and wet compression.
- B. Inspect and maintain inlet foggers, wet compression, evaporative coolers, chiller coils, and anti-icing heaters (if installed) in accordance with the OEM's instructions.

2.3.9.4.2 Inspect gas turbine external devices in accordance with the OEM's recommendations. At a minimum, ensure the following steps are included in the inspection, testing, and maintenance plan:

- A. Dismantle and inspect the compressor bleed valve for freedom of operation and possible damage. Inspect and calibrate the bleed valve linear variable differential transformer (LVDT) position or limit switches that indicate open and closed.
- B. Inspect the lubrication system, including pumps, filters, coolers, and instrumentation.
- C. Perform a complete check of the control system.
- D. Inspect shaft coupling.
- E. If a mechanical trip device is used, inspect the overspeed trip mechanism and calibrate the plunger spring tension.
- F. Check the alignment of gas turbine bearings with those of their driven machines. If alignment is made while the set is cold, use valid estimates of pedestal temperatures at operating conditions to set cold offsets so the bearings will be aligned properly at steady-state conditions. A hot alignment at steady-state temperature is a satisfactory alternative if it can be accomplished readily.
- G. Test and inspect the lube oil cooler temperature control valve on an annual basis to prevent malfunction and hot lube oil from inadvertently bypassing the lube oil coolers.

2.3.9.5 Dismantle Inspections

2.3.9.5.1 Due to the critical nature of the work being performed, ensure adequate supervision or oversight is present at all times during all dismantle inspections, whether through internal or third-party resources, to ensure the work is being performed in accordance with all applicable procedures. Ensure the service provider is following necessary rigging and lifting practices, and documenting all appropriate findings. Ensure data sheets are being completed properly, pertinent QA/QC checks are being carried out, and a robust foreign material exclusion program is enforced.

2.3.9.5.2 Combustion Section Inspection

The combustion section dismantle inspection described below does not apply to aeroderivative gas turbines. The combustors on an aeroderivative gas turbine can be inspected as part of the maintenance borescope inspection. The following is the minimum scope of work recommended for a combustion section inspection (perform additional work as recommended in the OEM's inspection procedures):

- A. For industrial gas turbines with can-annular combustors, inspect combustor or combustor baskets (or cans) and transition pieces (or combustion annulus) for distortion, cracking, or unusual discoloration.
- B. For industrial gas turbines with annular combustors, inspect dismantled burners and lances.
- C. For industrial gas turbines with silo combustors, inspect burners and flame cylinder end plates, ceramic tile linings of the flame cylinders, metallic hot gas path items, and mixing and inner casings.
- D. Inspect fuel nozzles for erosion and obstruction, igniters for proper functioning and intact wiring, and flame detectors for lens condition, soundness of wiring, and specified response.
- E. Inspect freedom of operation and leak test gas valves, fuel oil valves, and dual-fuel check valves.

- F. Inspect fuel manifold drain valves and combustion casing drain valve(s) for freedom of operation.
- G. Inspect first-stage turbine nozzle vanes as far as is possible from the combustor side. Also inspect turbine blades, turbine nozzles, and outer tip seals as far as possible using a borescope.
- H. Inspect inlet, including operation of anti-icing equipment (if installed).
- I. Inspect thermocouple harness, tubes for pressure sensors, and vibration instrumentation for cracked or broken leads and other possible damage.
- J. Inspect exhaust duct for warping, cracking, and evidence of overheating, as well as for soundness of seals.

2.3.9.5.3 Hot Gas Path Inspection

The following is the minimum scope of work recommended for a hot gas path inspection (perform additional work as recommended in the OEM's inspection procedures):

- A. For heavy-duty industrial gas turbines, remove upper half of turbine casing.
- B. For aeroderivative gas turbines, remove gas generator from the gas turbine enclosure; unbolting of hot-section subassemblies for access to high-pressure and low-pressure turbines.
- C. Inspect thermal barrier coating (TBC) for evidence of spalling, erosion, and/or thermal fatigue.
- D. Inspect, including nondestructive examination (NDE) to whatever extent possible, rotating blades (buckets) for corrosion and erosion, impact damage, and thermal-fatigue cracking.
- E. Remove nozzle diaphragm sections for NDE. Thermal cracking may be found in the nozzle vanes and in the platforms. Manufacturers have standards for action to be implemented in connection with such cracking, ranging from no action, to weld repair, to replacement, depending on the locations, lengths and depths of the cracks.
- F. Perform NDE inspections of turbine disks in blade attachment slots and at bolt holes and disk bores for cracks and corrosion to whatever extent possible.
- G. Refurbish parts in accordance with manufacturer's recommendations as indicated, i.e. blending of nicks, dents and small thermal cracks in rotor blades, blending and weld repair of nicks and thermal cracks in nozzle vanes, and cleaning of cooling passages.
- H. Measure the axial clearances between stationary nozzle diaphragms and rotating wheels, between blade tips and shrouds, and of labyrinth seals. Compare these measurements with the manufacturer's specifications and with previous measurements.

2.3.9.5.4 Major Inspection

The purpose of the major inspection is to evaluate all of the internal components of the machine from the inlet through the exhaust. The inspection includes the components previously inspected in the combustion and hot gas inspections. The major inspection also provides access to the compressor rotor and stationary compressor blading, as well as the bearing assemblies. In addition to the combustion and hot gas inspections, include the following in the minimum scope of work for a major inspection (perform additional work as recommended in the OEM's inspection procedures):

- A. Inspect rotor and stator compressor blades for rubs, impact damage, corrosion, pitting, bowing, and cracking.
- B. Check all radial and axial clearances, including tip clearances, against their original values.
- C. Inspect casings, shells, and frames/diffusers for cracks and erosion.
- D. Inspect compressor inlet and compressor flow-path for fouling, erosion, corrosion, and leakage.
- E. Visually inspect the compressor inlet including the condition of the IGVs, IGV bushings, and first stage rotating blades.
- F. Inspect bearing liners and seals for clearance and wear.
- G. Visually inspect compressor discharge case and turbine exhaust struts for signs of cracking.

H. Perform NDE inspections of components in accordance with the OEM's recommendations. Consider NDE inspection techniques such as ultrasonic, phased array, or ping testing (i.e., resonant frequency testing) to identify defects and deficient conditions of components which have become more prevalent in the industry.

2.3.9.5.5 Rotor Inspection and Overhaul

Inspect and overhaul the rotor in accordance with the OEM's recommendations. The interval is based on the expected end of service life condition for some of the rotor components and is generally a teardown inspection and is the repair/replacement interval for the rotor.

2.3.10 Operational Flexibility

As market demand changes, modes outside of base load operation become more common. These profiles include terms such as cycling, peaking, intermediate, and two-shifting. Aspects to consider include additional unit starts, low or partial load, fast start/shutdown, ramp rate, load following operation, and extended layup. These variations in operational profiles could have a profound impact on equipment and components stemming from operating outside of nominal design limits to how the unit is operated, environmental conditions, fuel type/quality, and unit design (heavy duty vs. smaller units). This may cause units to become more susceptible to damage mechanisms that can shorten the service life of the unit. Reference Data Sheet 7-109, *Fuel Fired Thermal Electric Power Generation Facilities*, for recommended equipment layup procedures.

2.3.10.1 For flexible units, have an engineering assessment performed by the OEM or alternative service provider if a unit is operating outside its design criteria and/or profile (i.e., integrity operating window). Refer to Data Sheet 9-0, *Asset Integrity*, for more details. Apply a management of change process which includes aspects such as plant operating procedures, starts/trips, inspection intervals, testing, maintenance schedule, and operating conditions. Include an evaluation of current and new failure mechanisms, and how the unit will be impacted with age, hours, and cycles. Increased frequency of outages or overhauls will be necessary if identified areas of concern cannot be adequately inspected. The installation of additional supervisory instrumentation may also be required if areas of concern cannot be adequately inspected.

2.3.10.2 Units in flexible operation will experience more frequent turning gear use and increased wear. Turning gear failure could lead to extended down time due to rotor bowing and the long lead time for replacement parts. Adopt a condition-based preventative maintenance approach, which includes an internal visual inspection at each scheduled turbine outage. Perform a daily external inspection for oil leaks, vibration or unusual noises. Develop a contingency plan and adequate sparing to reduce downtime based on the specific turning gear design. Reference FM Data Sheet 9-0, *Asset Integrity*, for contingency plans and sparing.

2.3.10.3 For gas turbines operating in synchronous condensing mode, install a synchro, self-shifting (SSS) clutch between the turbine and generator to prevent unwanted rotation of the gas turbine. For aerodynamically coupled gas turbines, the clutch should be installed between the generator and the power turbine. Reference Appendix A: Glossary of Terms for a definition of synchronous condensing.

2.4 Operators

2.4.1 Refer to Data Sheet 10-8, *Operators*, for guidance on operator training programs, the competence of operators in their day-to-day roles, the supporting management structure, and organizational culture.

2.4.2 Ensure operators are trained to identify operational deviations that may lead to equipment damage, such as fuel or water quality excursions.

2.4.3 Ensure there are procedures in place to evaluate the effects of these operational excursions on the safety of operating the equipment.

2.4.4 Due to operational profiles changing, adequate refresher training and material should be made available to refamiliarize operating crews with methods of identifying trends of an off-normal state, as well as preparatory guidance to emergency conditions based on these profiles.

2.4.5 Create an emergency operating procedure for investigating the cause and origin of a trip before restarting a turbine. Restarting the turbine without rectifying the root cause of the trip can lead to increased damage. If the operator completes an initial investigation and a restart results in the unit tripping a second

time, the issue should be elevated to management to initiate a formal root cause analysis (RCA) prior to restarting the equipment. Reference Data Sheet 10-8, *Operators*, and Data Sheet 7-43, *Process Safety: under Incident Investigations*.

The following items should be included in the procedure for Restarting a Turbine Following a Trip emergency operating procedure:

- Maintain copies of process alarms and trip sequence history from the data historian before and after the trip to determine the chain of events, the initiating event and which safety device triggered the trip.
- Record the operating conditions (MW output, ambient temp, cold/hot start) immediately prior to the trip to diagnose any operational transients or related abnormalities.
- Perform a local equipment inspection for abnormal conditions such as damaged instrumentation, tripped breakers, cracks, noise, smell, smoke, leaks, vibration, deformation, loose bolts, missing gaskets, blockage and overheating discoloration. Document any abnormal conditions with photographs.
- When participating in an OEM remote monitoring and diagnostics program, consult with the OEM specialists to determine the cause and remedy for the trip.
- Determine whether all recommended OEM alarms and trips are installed, and that none were bypassed at the time of the incident. Reference Data Sheet 10-8, *Operators*.
- If internal turbine damage is suspected, a borescope inspection should be performed to rule out any internal damage or to prevent intensifying the damage.
- Root cause analysis (RCA) lessons learned should be formalized into a written training document to share across the plant shift teams.
- Based on the results of the RCA, implement appropriate loss prevention strategies; and inform your FM field Engineer regarding any resulting risk improvements.

2.5 Contingency Planning

2.5.1 Equipment Contingency Planning

2.5.1.1 When a gas turbine breakdown would result in an unplanned outage to site processes and systems considered key to the continuity of operations, develop and maintain a documented, viable gas turbine equipment contingency plan per Data Sheet 9-0, *Asset Integrity*. See Appendix C of that data sheet for guidance on the process of developing and maintaining a viable equipment contingency plan. Also refer to sparing, rental, and redundant equipment mitigation strategy guidance in that data sheet.

In addition, include the following elements in the contingency planning process specific to gas turbines:

- A. OEM design information for the gas turbine unit
- B. Processes and procedures needed for removal, dismantling, transportation, availability and installation of a gas turbine unit and/or components.
- C. Review of any service contracts with OEM and/or vendors to identify the duration of delivery of the gas turbine unit and/or components.
- D. When applicable, OEM and/or third-party vendor review to determine the optimum spare part strategy. Refer to Appendix C for more information.

2.5.1.2 When required by the equipment contingency plan, properly store and maintain equipment breakdown spare parts/components and/or units to ensure the viability of the units.

2.6 Alerts

Original equipment manufacturers and alternative service providers issue technical bulletins or alerts when design or operating problems occur that differ from expectations. Establish a bulletin/alert management process to track, prioritize and implement the bulletins/alerts utilizing a management of change process to

address any impacts on programs, procedures and gas turbine integrity and reliability. Urgency and implementation are designated by the timing and compliance codes within the bulletin/alert.

3.0 SUPPORT FOR RECOMMENDATIONS

3.1 Inlet Air Systems

The inlet air filter house and ducting system are designed to minimize airborne contaminants that could cause erosion and corrosion of gas turbine components. Many factors affect the efficiency of the filter system, including the choice of filter media used and maintenance and installation practices. Improper design, installation and/or maintenance of the inlet system could cause bypassing of the filter media, leading to unwanted contamination of downstream components.

It is essential that the inlet system be properly designed, installed and maintained, with no leaks or bypasses into the clean air section.

The inlet filter elements should be maintained or replaced according to the overall maintenance schedule provided by the original equipment manufacturer. If foggers or evaporative coolers are used, it is critical to maintain water quality and establish rigid guidelines for media maintenance and water monitoring to ensure proper operation. It is essential to the integrity of the inlet system that all gaskets and bolted joints be installed correctly to minimize the risk of dirty air and/or water contaminating the clean air section of the gas turbine.

Maintenance and operation of a gas turbine are influenced by the quality of the air the turbine consumes. Airborne contaminants such as dust, salt, and oil can cause compressor blade erosion, corrosion, and fouling. Particles entering the compressor can cause significant blade erosion. Corrosion of compressor blading causes pitting of the blade surface, which, in addition to increasing the surface roughness, also serves as potential sites for fatigue crack initiation.

Sources of contamination can be both external and internal.

A. Potential **external sources** of contamination include the following:

1. Coastal sites (elevated concentration of sodium and potassium chlorides)
2. Dry lake beds (high salt content)
3. Corrosive elements in ambient air, such as chlorides, sulfates, and nitrates
4. Cooling tower drift due to facility arrangement, prevailing wind direction, and cooling-water chemistry (water source, chemical treatment, etc.)
5. Blowout from the surrounding equipment (steam, lube oil, compressor, etc.) into the inlet filter compartment and filters
6. Local industrial and agricultural activities having potentially elevated emission sources

B. Potential internal sources for contaminants include the following:

1. Air and water bypass around filtration systems (coalescers, moisture separators, pre-filters, and final filters) due to the following:
 - a. Open implosion doors, access doors, and hatches
 - b. Missing or improperly installed filters, gaskets, and associated caulking
 - c. Improper operation and maintenance of power augmentation and protection systems such as evaporative coolers, foggers, chiller coils, and anti-icing steam heaters
2. Evidence of a corrosive environment includes, but is not limited to, the following:
 - a. Significantly damaged, degraded, or continually wet filter media
 - b. Corrosion on inlet and upstream components/structure
 - c. Visible deposits or residue in the inlet or on the filter media

Maintenance and operation of a gas turbine is influenced by moisture intake to the gas turbine using inlet foggers or evaporative coolers for power augmentation. If inlet foggers and evaporative coolers are not operated and maintained correctly, the water may not be fully vaporized and visible water droplets may enter

the unit. These water droplets can collect and coalesce on inlet surfaces causing local thermal distortion of the inlet bell-mouth and compressor casing, which can cause blade rubbing or cause rubs to worsen. Water droplets can also cause leading edge erosion on the first few stages of the compressor. This erosion, if sufficiently developed, may lead to blade failure. Any source of visible water in the compressor inlet, including rainwater ingress and evaporative cooler sump overflow, can have these effects. The use of evaporative cooling and fogging in normally restricted when ambient temperatures are <50°F (10°C).

Experience has shown that, depending on the quality of water used and condition of the inlet silencer and ducting material, fouling of the compressor can be severe with inlet foggers or evaporative coolers. Operation of a compressor in such an environment may lead to long-term degradation of the compressor due to corrosion and erosion, fouling, and material property degradation. The OEM's water quality standards for inlet foggers or evaporative coolers should be strictly followed.

3.2 Fuel Supply System

3.2.1 Fuel Shutoff Valve Leakage

Fuel shutoff valves are typically fail-safe valves (i.e., fail-closed) and may also control fuel flow or pressure. Excessive leakage through fuel shutoff valves can lead to fires or explosions in the gas turbine exhaust system. Causes of excessive leakage include, but are not limited to, the following:

- Fouling of valve seats with contaminated fuel
- Out-of-calibration servo control cards
- Faulted or out-of-calibration instrumentation
- Worn components including position sensors
- Contaminated hydraulic fluid
- Assembly errors after valve maintenance

3.2.2 Fuel Shutoff Valve Leakage Testing

The following are examples of methods that can be used to ensure the shutoff valves in gaseous fuel systems meet the original equipment manufacturer's (OEM's) operational leakage limit criteria. For each application, the time duration and allowable pressure rise or pressure decay need to be determined by the OEM as a function of fuel pressure and pipe section volume. The values in the following examples are illustrative and are included to clarify the approach.

3.2.2.1 The following is an example of how to leak test the gaseous fuel system shutoff valves in a double block and bleed configuration (refer to Figure 2.2.4.2.1):

A. Valve V1 leakage test (test sequence during shutdown to prevent excessive leakage of gas to atmosphere through vent):

1. When the fuel system control logic shuts off the fuel, vent valve (V3) is opened, and the two fuel shutoff valves (V1 and V2) are closed.
2. To test V1, close the vent valve (V3).
3. Monitor the pipe section between the shutoff valves (V1 and V2) for a pressure increase. The allowable pressure increase should be within OEM's acceptance criteria. Typically, a pressure increase of more than 10 psi (0.7 bar) in 30 seconds is considered excessive.
4. Failure of this test indicates a failure or leak in the shutoff valve V1.

B. Valve V2 leakage test (test sequence during startup):

1. Prior to any startup sequence, the vent valve (V3) should be open, and the fuel shutoff valves (V1 and V2) are closed.
2. To test V2 during the startup sequence, close the vent valve (V3) and open V1.
3. Close V1.

4. Monitor the pipe section between the shutoff valves (V1 and V2) for a pressure decrease. The allowable pressure decrease should be within the OEM's acceptance criteria. Typically, a pressure decrease of more than 10 psi (0.7 bar) in 30 seconds is considered excessive.
5. Since valve V1 was proved leak-tight during the preceding shutdown, failure of this test indicates that a failure or leak in downstream shutoff valve V2 may have occurred. Leakage could also have been through vent valve V3.

3.2.2.2 The following is an example of a valve-proving system for a gas turbine with gaseous fuel systems as shown in Figure 2.2.4.2.2-1 and 2.2.4.2.2-2:

A. Valve V2 leakage test (test sequence during shutdown):

1. Gas vent valves (V4 and V5) are opened, and the three fuel shutoff valves (V1, V2, and V3) are closed when the fuel system control logic shuts off the fuel.
2. To test V2, close both vent valves (V4 and V5) and open V1.
3. Monitor the pipe section between the middle and most downstream shutoff valves (V2 and V3) for a pressure increase. The allowable pressure decrease should be within the OEM's acceptance criteria. Typically, a pressure increase of more than 10 psi (0.7 bar) in 30 seconds is considered excessive.
4. Failure of this test indicates that a failure or leak in the middle shutoff valve (V2) has occurred.

B. Valve V3 leakage test (test sequence during startup: Prior to any startup sequence, both gas vent valves (V4 and V5) are open, and the three fuel shutoff valves (V1, V2, and V3) are closed.

1. To test V3 during the startup sequence, close both vent valves (V4 and V5) and open V1 and V2.
2. Close V1 and V2 and open V4.
3. Monitor the pipe section between the middle and most downstream shutoff valves (V2 and V3) for a pressure decrease. The allowable pressure decrease should be within the OEM's acceptance criteria. Typically, a pressure decrease of more than 10 psi (0.7 bar) in 30 seconds is considered excessive.
4. Failure of this test indicates that a failure or leak in the most downstream shutoff valve (V3) may have occurred. Leakage could also have been through vent valve V5.

3.2.3 Alternative Fuels

Alternative fuels are fuels other than the standard natural gas and distillate fuel oils that are typically utilized in gas turbines. Some examples of alternative fuels currently in use are hydrogen, ethane, ammonia and naphtha.

Alternative fuels typically have a lower BTU content per volume and a lower heating value than conventional fuels, so a larger fuel volume is required to maintain turbine firing temperature and power output. Combustion pressure fluctuation/flame stability is a concern; ensure that auto-ignition and/or flame flash back upstream into the fuel nozzle area doesn't result in turbine damage. Other potential risks are leakage due to low molecular weight, fire/explosion, and hydrogen embrittlement fatigue cracking of certain stainless steel, carbon steel and titanium components.

Burning hydrogen results in a higher moisture content which also increases the degree of heat transfer to the hot gas path components. Another consideration of alternative fuels used in a combined cycle plant are the HRSG purge cycle requirements to prevent accumulation of explosive gasses prior to start-up. Refer to Appendix A for a definition of alternative fuels. See Data Sheet 7-91, *Hydrogen*, for more information.

3.3 Lube Oil System

For rotating machinery, a properly designed, installed, operated, and maintained lube oil system is critical. Because of the vital function of this system, it is essential to ensure the system configuration, including electrical and mechanical support systems, is inherently resilient (i.e., no single failure can result in the loss of equipment lubrication). Additionally, locked-open valves will assist in preventing the inadvertent closing of the identified single points of failure.

A lube oil system may service a single piece of equipment or a train of equipment. In some cases this system may also supply control oil and seal oil. The focus of this section is on the lube oil system itself.

Lube-oil temperature is a critical operating parameter; and if the gas turbine operates for an extended period of time at elevated lube oil temperatures, the bearings can be damaged due to a reduction in oil viscosity. Malfunction of the lube oil cooler temperature control valve will allow hot lube oil to bypass the lube oil coolers. The oil temperature will increase to a point of thermal breakdown and loss in viscosity resulting in metal-to-metal contact damage in the bearings.

3.3.1 Bearing Types

3.3.1.1 Units with Rolling Element Bearings

A typical lube oil system includes a shaft driven pump and scavenge pumps. These pumps are typically driven from an accessory gear box. The scavenge pumps remove oil from the bearing sumps and deliver it to an external reservoir, filter, and cooling systems. These units typically have shaft-driven positive displacement lube-oil pumps that provide an adequate oil supply for these bearings at various speeds, negating the need for external lube-oil pumps.

3.3.1.2 Units with Hydrodynamic Bearings

Typical lube-oil systems are likely to include one of the following configurations depending on the OEM, unit size, and the age of the system:

- A. Two 100% capacity ac lube oil pumps and dc motor or steam driven emergency pump.
- B. A main shaft driven pump, a motor-driven startup/shutdown pump, and a dc motor or steam driven emergency pump.
- C. Same as (A or B) except that, in place of the emergency pump, a gravity or pressurized rundown tank (designed in accordance with OEM recommendations) is used for emergency backup.

A simplified diagram showing a typical lube oil system that utilized two AC motor driven pumps and a DC motor driven emergency pump is shown in Figure 3.3.1.2.

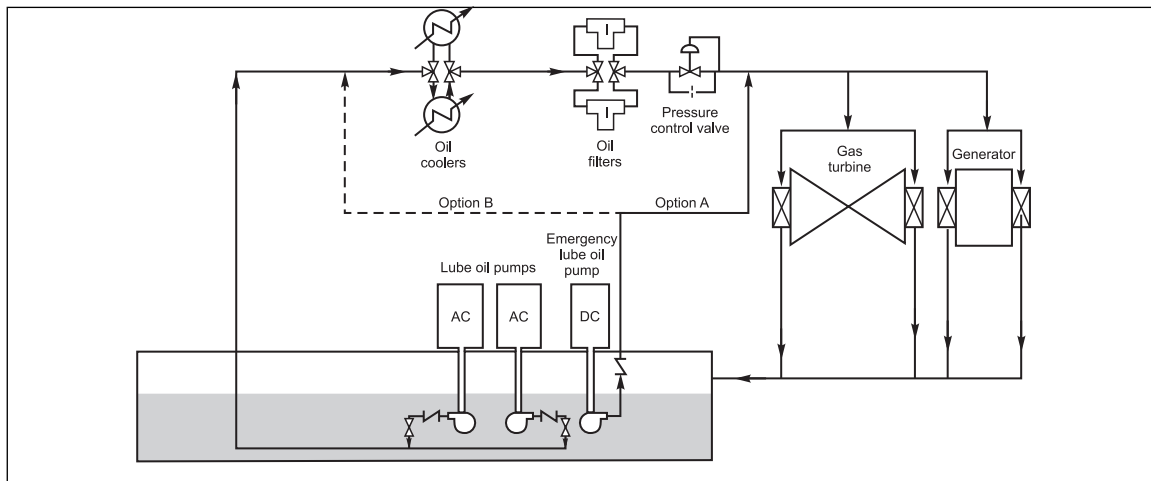

Fig. 3.3.1.2. Simplified lube-oil system for a gas turbine with hydrodynamic bearings

3.3.1.3 Thrust Bearing

A thrust bearing controls the axial position of the rotor in relation to the stationary turbine components. A thrust position monitor or thermocouples in the thrust bearing pads will provide early warning of thrust bearing failure due to a shift in rotor axial position or increased thrust bearing temperature. A thrust position monitor continuously measures the rotor thrust and monitors the rotor axial position within the thrust bearing relative to the axial clearances within the machine. Units equipped with a thrust bearing pad temperature monitoring

system can identify excess rotor thrust pressure and accelerated wear by an increasing trend in temperature (with alarm and trip settings). See Table 2.2.1 and Appendix A for more information on thrust bearings.

3.3.2 Mechanical System Resiliency

To illustrate the concept of mechanical system resiliency, refer to the system in Figure 3.3.1.2. In Option A the discharge of the DC emergency lube oil pump ties into the system after all of the system auxiliaries and with no intervening devices between the pump discharge and the bearings to be lubricated. Consequently, the flow from the emergency DC pump can flow directly to the bearings thus minimizing the risk of a lube oil loss.

In the system configuration shown as Option B, the discharge of the DC emergency lube oil pump ties into the system before the oil coolers, oil filters and the pressure control valves. These intervening devices increase the risk of a failure should one of the filter or cooler transfer valves fails and block flow or if the pressure control valve were to fail closed and block flow. In essence, this reduces the resiliency of the system. This risk can be mitigated by doing the following:

- A. Altering the configuration of the discharge pipework from the DC emergency lube oil pump so the discharge from the DC emergency lube oil pump feeds directly to the turbine-generator bearings (Option A in Figure 3.3.1.2). This oil feed line should be unimpeded and without valves.
- B. If altering the systems is not an option, do not attempt to changeover the filters or the cooler when the unit is online.
- C. If neither of the above are options and changeover is needed while online, provide procedures and operator training to ensure that the operators are aware of the potential risk of changing over the filters or coolers online and ensure they follow an appropriate changeover procedure. Any control valves after the DC pump piping connection should fail in the open position and any isolation valves should be locked open.

3.3.3 Electrical System Resiliency

Insufficient electrical system resiliency has led to multiple lube oil system failures that consequently led to significant mechanical damage. Predominantly, single DC bus systems designed to provide power for the unit digital control system, protection, and the emergency lube oil DC pump led to multiple losses in the industry.

When a single DC bus system is designed to provide power for the entire DC load, there is a potential for a unit trip and loss of electric power to the emergency lube oil pump when DC power is lost. If the AC pump(s) require DC power to either stay in operation or start up on low oil pressure, the resulting damage from lube oil starvation can be significant.

Independent DC systems for the emergency lube/seal oil system and for the control/ protection systems allow for a more resilient lube oil system. When a single DC bus system is designed to provide power for the entire DC load, the reliability of the AC lube oil pump should be ensured. This can be achieved by using fail-safe designs. In some designs fail-safe AC pumps are achieved by using the scheme of de-energizing in motor control circuit (MCC) to start the motor. This means normally energized (closed) coil of the relay in the control logic when the motor starter is in "auto position. To start the motor or to maintain the motor in running status, the relay coil is de-energized (open). It is also referred as "drop-out-to-run" design. By this method, the risk of failure to start the motor when required can be reduced. The intent of the recommendations in Section 2.2.6 is to ensure maximum reliability (resiliency) of the lube oil supply to turbine-generators, compressors, etc.

3.3.4 System Design Review

Careful review of the mechanical and electrical systems is needed to identify scenarios in which component failure and/or operator error could result in the failure of the emergency lube oil system. This hazard analysis can be done using a recognized methodology such as HAZOP (hazard and operability) or FMEA (failure modes and effects analysis). If the study identifies any deficiencies, these deficiencies should be remedied as soon as possible. See FM Property Loss Prevention Data Sheet 7-43, *Process Safety*.

3.4 Overspeed Trip System

3.4.1 Gas turbine control and protection system technology has evolved over the years to improve reliability and to accommodate increasingly complex operating requirements. Overspeed trip systems commonly found in gas turbines include:

- A. Mechanical bolt with single circuit electronic back-up activated by a relay from the main control sensor and circuit
- B. Electronic 2-out-of-3 voting logic activated by relays from sensors in the main control circuit
- C. Electronic 1-out-of-2 voting logic activated by relays and circuitry independent from the main control loop
- D. Electronic 2-out-of-3 voting logic activated by sensors and circuitry independent from the main control loop
- E. Mechanical bolt primary with independent electronic 2-out-of-3 voting logic back-up

3.4.2 Simulated overspeed trip system testing is typically achieved by one of the following methods (electronic systems only):

- A. A simulated test can be programmed into the control system and performed periodically. Depending on the system configuration, testing can be done while the turbine is online or offline.
- B. A simulated test can be performed using signal generators to simulate the overspeed condition and verify system integrity. Depending on the system configuration, testing can be done while the turbine is online or offline. If, in the process of doing a simulated test, it is necessary to use jumpers or to force logic, procedures should be in place to ensure the system, or portion of the system, is returned to its initial configuration before putting the full system back into service.
- C. In some modern control/protection systems with self-diagnostic capability it may be possible to achieve the same level of testing as a simulated test (Section 2.2.2.4) during startup and operation. Testing of the functionality of the components, circuit boards, and circuit board logic is normally done in the startup mode. Failure of a component or circuit can also be detected during operation and the failure will be identified and an alarm sent. If a unit has a self-diagnostic system, it should be confirmed that the level of testing matches or exceeds the level identified for the simulated test in Section 2.2.2.4. If this level of testing can be verified, it should be deemed an acceptable simulated test.

3.4.3 The systems listed above have been proven in service with those incorporating electronic 2-out-of-3 voting logic having higher reliability and, based on design logic, providing less chance for false trips.

3.4.4 Independent governor control/emergency trip circuitry is preferred.

3.5 Exhaust Temperature Control and Protection System

An over-temperature protection system protects the gas turbine against possible damage caused by over-firing the unit. Over-firing will negatively influence the service life of the hot gas path components and in the extreme, can lead to catastrophic component failures. Since it is not practical to directly measure the actual firing or turbine inlet temperature, this temperature is implied from the exhaust temperature measurements. Under normal operating conditions, the exhaust temperature control system reacts to regulate fuel flow when the firing temperature limit is reached. However, in certain failure modes the exhaust temperature and fuel flow can exceed operating limits. If this occurs, the over-temperature protection system provides an over-temperature alarm annunciation that allows the operator time to unload the gas turbine to avoid tripping the unit. If the temperature continues to increase, the gas turbine is tripped.

3.6 Condition Monitoring

Condition monitoring is a key component of a condition-based or predictive maintenance strategy. Condition monitoring is based on trending critical parameters to identify equipment degradation and to detect/predict incipient failures. Some of the key elements of a condition monitoring system for a gas turbine are included in the following sections. When the results from these different elements are combined, the ability to isolate the location of problems can be improved.

3.6.1 Exhaust Gas Temperature Spreads

An excessive exhaust gas temperature spread can be indicative of problems with the combustion system. It is important to establish a baseline value of the exhaust temperature spread with which to compare future data. When evaluating exhaust temperature spreads, it is not necessarily the magnitude of the spread, but the change in spread over a period of time that may be indicative of a problem. The accurate recording and plotting of exhaust temperatures can be helpful in diagnosing developing combustion problems.

3.6.2 Vibration Monitoring

Vibration monitoring is an effective technique to detect mechanical defects in a gas turbine. Regular vibration monitoring can detect bearing deterioration, mechanical looseness, and worn gears. It can also identify misalignment and rotor imbalance before it results in bearing or shaft damage. It is important to establish a baseline value of the vibration with which to compare future data. When evaluating vibration measurements, it is not necessarily the magnitude of the vibration, but the change in vibration over a period of time that may be indicative of a problem. Using vibration measurements in conjunction with lube-oil conditions and lube-oil or bearing metal temperatures has proven useful in many situations. Refer to ISO 10816 for references of vibration severity.

3.6.3 Performance Monitoring

Thermodynamic and compressor performance monitoring provides insight into equipment degradation by comparing measured gas turbine performance against a model of “expected” performance for the current ambient operating conditions, corrected to ISO conditions. It can be used to optimize maintenance planning, such as identifying the ideal time to perform a compressor water wash, and to identify incipient failures.

3.6.4 Combustor Dynamics Monitoring

Today's lean-burning gas turbines operate on the verge of flame-out to achieve the extremely low emissions required by environmental restrictions. Combustion instabilities resulting in pressure pulsations in the combustors are a consequence of this lean-burn operation. If left unchecked, these pulsations can cause high-cycle fatigue to the hardware and quickly damage components. Exhaust gas temperature spreads can detect some major instabilities but cannot detect incipient combustion instabilities. If a combustion system has a history of combustion dynamics issues, the OEM typically recommends that a combustion dynamics monitoring system, or CDMS, be installed.

3.6.5 Lube Oil Testing

The lube-oil system is designed to supply filtered lubricant at the proper pressure, temperature and viscosity for the operation of the turbine and its associated equipment, therefore monitoring the lube oil system is paramount to the operation of the unit. This should include analysis of the lube oil condition to provide a remaining useful life parameter, contamination concentration, and internal equipment condition to identify wearing of components.

Additionally, alert action items should be implemented to provide indications that a change has occurred in the system and needs further investigation. Internal analysis methods should be audited periodically for accuracy, and outsourced vendors should have undertaken a vetting process by the owner/operator. See Appendix C for more information.

3.7 Compressor Stall, Surge and Protection

3.7.1 Design features such as inlet guide vanes, variable-pitch stator vanes, compressor bleed valves, casing treatments and tip clearance controls are used to avoid compressor stall. The variable inlet guide vanes and the compressor bleed valves function together to limit air flow and control pressure in the compressor stages during turbine startup and shutdown. The purpose is to improve the compressor surge margin and eliminate stall.

3.7.2 Compressor surge results when a stall disturbance in compressor axial flow escalates into a rapid flow rate pulsation that becomes so violent that reverse flow is induced, accompanied by a loud “bang”. Small pressure waves are precursors to the rotating stall that escalates into surge. Violent surge events have resulted in combustor, compressor, inlet duct and thrust bearing damage.

3.7.3 Modern gas turbines are typically equipped with compressor surge detection systems to detect and prevent surge conditions. In a typical surge protection system, three differential pressure signals are monitored; and if 2-out-of-3 signals indicate that surging has occurred, a gas turbine trip will be actuated. Surge protection systems monitor the compressor mass flow during operation to prevent extreme loading and damage to compressor blading. The gas turbine trip has to be actuated immediately, because surges are very short events; and the reaction speed of the sensors and the protection logic must be fast. The measurable indicators of a surge event are rapid drop in compressor discharge pressure, spike in bearing vibrations, rise in turbine exhaust and compressor inlet temperatures and a drop in inlet filter pressure delta to zero or negative.

3.8 Turbine Wheel Space/Disc-cavity Temperatures

High temperature hot gas ingestion into the turbine wheel space/disc-cavity region can damage the rotor metallurgical properties due to oxidation, creep and temper embrittlement. An alarm setpoint provides protection and notification of an adverse condition. High temperatures indicate wear of the rotor body gas seals between turbine stages or a loss of cooling flow due to damaged turbine vanes or blades. The turbine vanes allow cooling air to pass to the interstage seal cavity/wheel space regions. The cooling air maintains an acceptable temperature environment in the turbine rotor disc cavity/wheel space regions.

3.9 Starting System

The starting system accelerates the gas turbine from turning gear speed to ignition speed and up to self-sustaining speed. Once the gas turbine reaches self-sustaining speed, the starting system disengages, shuts down and the GT accelerates on its own to its rated speed. The starting system also provides a means to purge the gas turbine and HRSG (if equipped) of any combustible fuel prior to ignition. It can also be used after shutdown to spin cool the gas turbine for maintenance or borescope inspections. It is also used to perform offline compressor water washing tasks.

Several types of starting systems are utilized for existing aeroderivative, industrial and generator drive gas turbines. These include pneumatic air motors (blowers), hydraulic motors, AC or DC electric motors, and internal combustion (gas or diesel) motors (common for black start units). Starting system prime movers typically use speed reducing gearboxes, torque converters and SSS-Clutches that disengage the starting system when the gas turbine speed is greater than the starting prime mover. Aeroderivative gas turbines typically use air or hydraulic motors, while D, E, and F class gas turbines utilize a large AC electric motor with a speed reduction gear box, a torque converter and an SSS-Clutch. The rotor turning gear equipment is typically integrated with the starting system gearbox.

New modern gas turbines utilize a Load Commutating Inverter (LCI) or Static Frequency Converter (SFC) adjustable frequency drive which energizes the generator as a synchronous motor to rotate the GT to ignition speed and self-sustaining acceleration. When the gas turbine reaches synchronous speed, the generator switches back from a motor to a generator.

Some multi-unit gas turbine plant designs use one LCI/SFC that is cross connected to start up one gas turbine at a time. This poses a single point failure risk, especially for a plant used in flexible operation, as it may pose a 100% time-element exposure. Other multi-unit gas turbine plants may have a more favorable configuration with a dedicated LCI/SFC for each GT, cross connected to start any one unit with tie switches between the starting buses. In this situation, multiple gas turbines can be started simultaneously if the customer's system permits. If one of the LCI/SFC starters fails, the other can be used to start the unit.

The LCI/SFC protective strategy provides a high level of fault protection that includes voltage surge protection and full fault suppression capability for internal faults or malfunctions. A drive system monitor and diagnostic fault indication continuously monitors the condition and operation of the LCI/SFC. It also provides ground fault and phase overcurrent protection.

The frequency of the starting system inspection and maintenance intervals are dependent on how often the gas turbine is started (flexible operation) and the ambient environmental conditions. Units in flexible operation will require more frequent inspections than a base-loaded gas turbine, and the OEM should be consulted for maintenance intervals based on the individual unit's operating history.

3.10 Rotor Remaining Useful Life and Service Life Extension Options

When considering the rotor remaining useful life for a specific gas turbine model, follow the OEM's recommended rotor guidance. The OEM will recommend a specific factored fired start (FFS)/equivalent start

(ES) or factored fired hour (FFH)/equivalent operating hour (EOH) interval when the rotor should be retired, replaced or receive a service life extension requalification. Some OEMs have applied a hard stop for rotors that have achieved a certain high level of fired starts/equivalent starts. Failure to perform a rotor remaining useful life inspection leaves the gas turbine at a greater risk of failure.

A rotor service life extension may be viable on a case-by-case basis dependent on the condition of the rotor, the specific rotor design, operating history, and prior maintenance or upgrades performed. When a Rotor Service Life Extension is a viable option, expect that some rotor components will either have reached the end of their service life or will have a minimal amount of remaining useful life and will require repair or replacement. Depending on the extent of refurbishment and part replacement, future rotor inspections may be required at a reduced interval.

The service life extension requires rotor removal, disassembly (unstacked), and thorough dimensional, NDE, and metallurgical evaluation. Some rotor components may require replacement based on inspection findings. A complete compressor and turbine rotor inspection includes surface and sub-surface non-destructive examination completed through magnetic particle, eddy current, x-ray, ultrasonic testing (UT), Phased-array UT, dimensional and metallurgical testing. Based on the results of the inspection, the rotor may be replaced with a new rotor, the rotor may receive a service life extension, or the rotor may be exchanged with a spare requalified rotor from another plant to reduce repair cycle time.

The service life extension requalification scope of work should be documented in a report. The report should provide the estimated remaining useful life in hours and starts, so the remaining useful life and next rotor inspection interval can be established.

3.11 Scheduled Inspection, Testing, and Maintenance

There are many factors that influence component life, and these must be understood and accounted for when planning inspection, testing, or maintenance activities. Some key factors in determining the inspection, testing, and maintenance interval requirements are starting cycle (hours per start), power setting, fuel, level of steam or water injection, and site environment. These factors directly influence the service life of replaceable gas turbine parts.

The methods of determining the recommended inspection interval differ by OEM and class of machine. These intervals are usage-based and do not consider the actual operating experience or the environment in which the machine operates. As a result, there are considerations for intervals based on average, base-loaded, natural gas-fired operating conditions.

4.0 REFERENCES

4.1 FM

Data Sheet 5-12, *Electric AC Generators*
Data Sheet 5-17, *Motors and Adjustable Speed Drives*
Data Sheet 5-28, *DC Battery Systems*
Data Sheet 7-43, *Process Safety*
Data Sheet 7-59, *Inerting and Purging Vessels and Equipment*
Data Sheet 7-79, *Fire Protection for Gas Turbines and Electric Generators*
Data Sheet 7-95, *Compressors*
Data Sheet 7-109, *Fuel-Fired Thermal Electric Power Generation Facilities*
Data Sheet 9-0, *Asset Integrity*
Data Sheet 10-8, *Operators*
Data Sheet 13-7, *Gears*
Data Sheet 13-18, *Industrial Clutches and Clutch Couplings*
Data Sheet 13-26, *Internal Combustion Engines*

Understanding the Hazard: *Combustion Turbine* (P0230)
Understanding the Hazard: *Outages at Power Generation Facilities* (P15110)
Understanding the Hazard: *Vibration of Rotating Equipment* (P0178)
Understanding the Hazard: *Lube Oil Testing* (P0219)
Understanding the Hazard: *Turbine Corrosion Due to Poor Water Quality or Steam Purity* (P0272)

Understanding the Hazard: *Flexible Operations in Thermal Power Generation (W333750)*

Understanding the Hazard: *Power Generating Assets Due for Retirement (W333404)*

4.2 Other

National Fire Protection Association (NFPA). NFPA 85, *Boiler and Combustion System Hazards Code*.

International Standards Organization (ISO). ISO 8217:2017, *Petroleum Products-Fuels (class F)-Specifications of Marine Fuels*.

International Standards Organization (ISO). ISO 10816, *Mechanical Vibration-Measurement and Evaluation of Machine Vibration-Part 8: Reciprocating Compressor Systems*.

APPENDIX A GLOSSARY OF TERMS

Aeroderivative gas turbine: Units derived from aircraft jet or fanjet engines. Typically, the gas generator section will be derived from an aircraft engine and the balance of the turbine designed for power (drive) applications.

Alternative fuels: Are fuels other than standard natural gas (methane) and distillate fuel oils (low sulfur diesel, No. 2 fuel oil, kerosene or jet fuel) that are typically utilized in power generating gas turbines. Examples of alternative fuels consist of but are not limited to landfill gas, bio gas, naphtha, syngas, methanol, steel mill flue gas, refinery flare gas, liquified petroleum gas (LPG), propane, ethane, hydrogen, and ammonia.

Alternative service provider (ASP): An entity that is not affiliated with the original equipment manufacturer.

Base load unit: A generating unit operated at or near full capacity on a nearly continuous basis.

Bearings: Anti-friction roller and ball bearings, commonly found on aeroderivative gas turbines, carry a shaft load by interposing rolling elements between an inner and outer race. Either can carry radial or thrust (axial) loads or both. Large industrial gas turbines utilize hydrodynamic sleeve type journal bearings incorporating tilting pads that aid in rotor alignment and stability.

Coast-down time: When a gas turbine trips and the fuel supply is cut off, coast-down time (also called run-down time) is the time it takes for the rotor to coast down from its rated operating speed to a stop or turning gear speed (~6 RPM). A typical industrial gas turbine coast-down time is 30 minutes.

Compressor stall: Occurs when boundary layer separation initiates along the compressor airfoils. The compressor can no longer push the air downstream and can spread into a rotating stall condition. Compressor stall can result from compressor degradation, which includes:

- Inlet guide vane and variable stator vane bushing and linkage wear causing off-design airflow angles
- Excessive blade tip and seal leakage
- Increased airfoil surface roughness
- Oil and dirt deposits fouling the compressor flow path or a sudden downstream backpressure event (blockage in the combustor or turbine)

If left unaddressed, rotating stall can escalate into an extreme case of compressor failure called surge.

Compressor surge: results when a stall disturbance in the compressor axial flow escalates into a rapid flow rate pulsation that becomes so violent that reverse flow is induced, accompanied by a loud "bang". Small pressure waves are precursors to the rotating stall that escalates into surge. Some of the potentially measurable indicators of a surge event are a rapid drop in compressor discharge pressure, a spike in bearing vibrations, a rise in turbine exhaust and compressor inlet temperatures and a drop in inlet filter pressure delta to zero or negative. Modern gas turbines are equipped with surge detection systems to detect and prevent surge events.

Cycling unit: Cycling involves a generating unit being removed from service frequently to satisfy market conditions and load demand requirements. Mechanical and thermal stresses may significantly increase when compared to a base load unit.

Duty Cycle: is a term used to define a turbine's operating profile based on the annual number of starts or hours accumulated. A high duty cycle is defined as annual start-stop cycles greater than 100 or annual operating hours > 5,000. Low duty cycle is defined as annual start-stop cycles ≤ 100 or annual operating hours ≤ 5,000.

Fail-safe condition: When a piece of machinery or other component reverts to a safe condition in the event of breakdown or malfunction.

Fired factored hours (FFH)/Equivalent operating hours (EOH): is used to calculate maintenance intervals and considers the effects of the duty cycle, fuel type, load setting and steam/water injection.

Fired factored starts (FFS)/Equivalent starts (ES): is used to calculate maintenance intervals and considers the effect of fuel type, load setting (part load, base load, peak load), peaking-fast starts, trips (trip severity factor) and load step changes and steam/water injection.

Flexible operation: A term more commonly used to cover various modes of operation, and occasionally synonymous with cycling. Flexible operation includes the following main operational modes:

- Startup/shutdown cycling
- Load following/load cycling
- Minimum load operation
- Higher ramp rate (fast start, forced cool down)
- Weekend/extended shutdowns

Flexible operations can be attributed to a plant's cost of fuel and its competition with cheaper forms of electrical generation (renewables). Conventional power plants may be called upon to cycle to smooth load fluctuations produced by renewable energy, primarily wind and solar energy.

Functional overspeed test: A functional (fired) test of the overspeed trip system, performed at or below rated overspeed, to verify the system integrity. The full functional test ensures all system components are tested in concert with one another and includes verification of the mechanical or electronic overspeed trip mechanisms, positive closing of the fuel valves, and for generator-drive gas turbines, the proper functioning of the reverse power relay 32 to disconnect/open the generator breaker.

Hydrodynamic (sliding) bearings: Bearings that carry a shaft load on a self-renewing film of lubricant. Thrust bearings support the axial loads, and radial loads are supported by journal bearings.

Industrial (frame) gas turbine: Any gas turbine manufactured solely for use in industry. The larger machines (OEM dependent, typically >100MW) are referred to as "heavy-duty gas turbines" and the smaller units (OEM dependent, typically 5-70MW) as "packaged gas turbines."

Integrity operating window (IOW): Sets of limits used to determine the different variables that could affect the integrity and reliability of a piece of machinery or process. Machinery operated outside of IOW's may cause otherwise preventable damage or failure.

Load following unit: A generating unit operated over a range of MW versus standard base load MW output to satisfy grid demand. Due to load changes required for these output variations, thermal stresses may see a significant increase.

Microturbine: A small gas turbine engine typically of radial design, closer in concept to low-cost turbochargers than the more complex axial industrial and aeroderivative gas turbines. The size of these machines is usually 2 MW or less.

Peaking unit: A generating unit that undergoes load following profiles but with additional attributes of high load-change ramp rates. Units of this profile may see increased thermal stresses due to the cyclic nature of the required load changes.

Ping test: Physical test to determine the natural and resonant frequencies of an assembly

Rolling element bearings: Bearings that carry a shaft load by interposing rolling elements between an inner and outer race. The two general types of rolling element bearings are ball and roller. Either can carry radial or thrust (axial) loads or both.

Runback: A reduction in load due to upset conditions during operation.

Simulated overspeed test: A test in which the functioning of the overspeed response, signal transmission, and emergency shutoff valve control respond to a simulated overspeed signal. Simulated tests typically do not test the emergency trip device and the fuel shutoff valves. The test can be conducted while the unit is online, without actually overspeeding it.

Synchronous condensing operation: A gas turbine generator can be operated as a synchronous condenser (SC), providing grid stability in the form of frequency and VAR support. Synchronous condensers are beneficial in renewable energy intensive grids. During synchronous condensing operation, the gas turbine is initially fired to synchronize the generator to the grid; then it is shut down and disconnected from the generator. This disconnection can be by means of a clutch installed between the generator and turbine, or by shutdown of an aerodynamically coupled gas turbine. During operation, the generator is still synchronized to the grid and rotating at operating speed, but the gas turbine is unfired.

Thrust bearing: Gas turbines are designed with inherently opposing thrust forces between the compressor and turbine sections that helps to balance rotor axial thrust. A thrust bearing controls the axial position of the rotor in relation to the stationary turbine components. Aeroderivative gas turbines may use a single angular contact ball bearing with a rotor thrust balance piston to maintain load on the thrust bearing or a double angular contact ball bearing that controls thrust in both axial directions. Industrial gas turbines typically utilize a tilting pad Kingsbury style thrust bearing to maintain axial loads in both directions.

Triple modular redundant (TMR): A fault-tolerant system in which three systems monitor a process and the results are processed by a voting system to produce a single output. If any one of the three systems fails, the other two systems can correct and mask the fault. If the voter fails, the complete system will fail; however, in TMR systems the voter is much more reliable than the other TMR components.

Turndown: A generating unit that undergoes load changes to minimum operating parameters, typically to limit start/stop cycles while remaining connected to the grid.

APPENDIX B DOCUMENT REVISION HISTORY

The purpose of this appendix is to capture the changes that were made to this document each time it was published. Please note that section numbers refer specifically to those in the version published on the date shown (i.e., the section numbers are not always the same from version to version).

October 2024. Interim revision. Minor editorial changes were made.

July 2024. Interim revision. Clarifications were made to the following:

- A. Added a DC emergency lube oil pump motor thermal overload alarm to Table 2.2.1
- B. Provided clarifications for lube oil DC power supply systems.
- C. Added guidance to test, repair or replace emergency lube oil pumps which have experienced a thermal overload alarm.
- D. Added guidance to provide an emergency operating procedure to manually rotate a hot rotor when the turning gear is not available.
- E. Recommend adding an alarm to prevent starting the turbine whenever the emergency lube oil pumpbreaker is not in the "Auto" position.
- F. Added clarifications to emergency lube oil system testing.
- G. Added lube oil cooler temperature control valve guidance.
- H. Provided a redirect to Data Sheet 7-109 for recommended equipment layout procedures.
- I. Added guidance for flexible units to have an engineering assessment performed if a unit is operating outside its design criteria.
- J. Added turning gear inspection and maintenance guidance for units in flexible operation.
- K. Added guidance for units in synchronous condensing operation.
- L. Added a definition for synchronous condensing operation in Appendix A Glossary of Terms

January 2024. Interim revision. Lube and seal oil systems Section 2.2.6.4, Item 4 b & c was changed from 12 hours to 8 hours to reflect that batteries are designed to provide the design duty cycle for 8 hours.

July 2023. Interim revision. Editorial changes made for additional clarity on service life and remaining useful life terminology.

February 2023. Interim Revision. Made editorial changes to provide additional clarity:

- A. Updated Alarm and Trip Summary for Protective Systems in Table 1.
- B. Added recommendations to provide continuous online turbine rotor wheel space or disc-cavity temperature alarm for elevated temperatures.
- C. Added recommendations to provide independent backup power systems for lubrication pumps to prevent single-point failures and guidance on backup battery capacity to align with Data Sheet 13-3, *Steam Turbines*.
- D. Added a recommendation to provide an emergency operating procedure to manually rotate a hot rotor to prevent rotor bowing when no lube oil or turning gear is available.
- E. Added recommendations for AC or DC lube-oil pump powered by an internal combustion engine backup generator.
- F. Added recommendations for bearing temperature and vibration detection.
- G. Added recommendations for gas turbine compressor surge protection.
- H. Added recommendations for electronic overspeed trip system testing to align with Data Sheet 13-3.
- I. Added recommendations for mechanical drive gas turbine overspeed testing to align with Data Sheet 13-3.
- J. Added recommendations for fuel supply quality, test firing alternative fuels and layup of alternative fuel systems.
- K. Added recommendations for gas turbine starting systems.
- L. Added recommendations to establish an effective lube-oil system condition monitoring program to align with Data Sheet 13-3.
- M. Added recommendations for gas turbine rotor lifetime extension and rotor requalification.
- N. Added recommendations for investigating the cause and origin of a unit trip before restarting the turbine to prevent increased damage.
- O. Added recommendations for thrust bearing guidance.
- P. In Appendix A, Glossary of Terms, added definitions for alternative fuels, coast down time, compressor stall and surge, duty cycle, fired factored hours, fired factored starts, flexible operation and thrust bearings.

July 2022. Interim revision. Made editorial changes to provide additional clarity on gas turbine bulletins/alerts.

January 2022. Interim revision. Minor editorial changes were made.

October 2021. Interim revision. Minor editorial changes were made.

April 2021. Interim revision. Minor editorial changes were made.

January 2021. Interim revision. Added guidance to support air inlet and power augmenting systems.

October 2020. Interim revision. Minor editorial changes were made.

July 2020. Interim revision. Updated contingency planning and sparing guidance. Added new terms to the Glossary.

July 2019. Interim revision. Minor editorial changes were made.

April 2019. This document has been completely revised. Significant changes include the following:

- A. Added guidance for overspeed and lube-oil protection systems, in addition to lube-oil testing.
- B. Added guidance for auxiliary systems and their associated hazards.

- C. Added guidance on an audit and inspection program for evaluating alternative service providers.
- D. Added inspection, testing, and maintenance (ITM) strategies, where applicable, regarding intervals and associated programs.
- E. Addressed flexible operation and industry trends.

January 2019. Interim revision. Minor editorial changes were made.

October 2018. Interim revision. Minor editorial changes were made.

April 2018. Interim revision. Minor editorial changes were made.

October 2017. Interim revision. Minor editorial changes were made.

April 2017. Interim revision. Minor editorial changes were made.

April 2012. This data sheet has been completely revised and reorganized. The main thrust of the reorganization was to combine the loss prevention recommendations common to heavy-duty and aeroderivative gas turbines.

Technical changes include the following:

- Added inlet air system recommendations
- Updated overspeed protection recommendations
- Removed cooling air flow and temperature alarm and trip recommendations
- Updated lube-oil temperature trip recommendations
- Addressed condition monitoring (EGT spread, vibration, performance monitoring)

May 2010. Minor editorial changes were done for this revision.

January 2005. The following changes were done for this revision:

1. Section 2.1.2.1, Maintenance Testing. Overspeed revised from actual to simulated at less than rated speed.
2. Section 2.1.2.6. Revised to be consistent with 2.2.2.6. Actuation of back-up lube oil pump quarterly versus weekly. Quarterly is adequate for verification of functionality. The emergency pump provides further back-up.

May 2003. Minor editorial changes were done for this revision.

January 2001. This revision of the document was reorganized to provide a consistent format.

APPENDIX C GUIDELINES FOR AN AUDIT AND INSPECTION PROGRAM FOR ALTERNATIVE SERVICE PROVIDER (ASP) SERVICES AND COMPONENTS

When equipment services and/or components are being (or have been) procured, an Audit and Inspection (A&I) Program should be in place to ensure that quality components and services are being procured. See Data Sheet 9-0, *Asset Integrity*, for universally applied equipment guidance.