

DATA CENTERS AND RELATED FACILITIES

**Table of Contents**

	Page
<b>1.0 SCOPE</b> .....	4
1.1 Hazards .....	4
1.2 Changes .....	4
<b>2.0 LOSS PREVENTION RECOMMENDATIONS</b> .....	5
2.1 Introduction .....	5
2.2 Construction and Location .....	5
2.2.1 General .....	5
2.2.2 Walls .....	6
2.2.3 Doors and Windows .....	6
2.2.4 Penetrations .....	7
2.2.5 Ceilings .....	7
2.2.6 Floors .....	7
2.2.7 Cables .....	7
2.2.8 Cable Raceways and Routing Assemblies .....	7
2.2.9 Insulation .....	8
2.2.10 Earthquake .....	8
2.2.11 Windstorm .....	9
2.2.12 Flood/Storm Water Runoff .....	9
2.3 Occupancy .....	9
2.3.1 General Data Center Areas (Offices, Lobby, Security) .....	9
2.3.2 Data Processing Equipment Room .....	9
2.3.3 Tape Cartridge Storage Rooms .....	20
2.3.4 Storage and Maintenance Areas .....	21
2.3.5 Utilities and Support Systems .....	21
2.4 Protection .....	28
2.4.1 General .....	28
2.4.2 Portable Fire Extinguishers .....	28
2.4.3 Detection: Design Specifications .....	28
2.4.4 Suppression: Design Specifications .....	30
2.5 Equipment and Processes .....	39
2.5.1 Mobile/Modular Data Centers .....	39
2.5.2 Network/Broadcast Control Rooms .....	40
2.5.3 Diagnostic Equipment .....	41
2.6 Inspection, Testing, and Maintenance .....	41
2.6.1 Heating, Ventilation and Air Conditioning (HVAC) .....	42
2.6.2 Fire Protection .....	42
2.6.3 Electrical Power Distribution .....	43
2.7 Human Element .....	43
2.7.1 Facilities .....	43
2.7.2 Emergency Response Team (ERT) .....	44
2.7.3 Power Isolation Plan .....	44
2.7.4 Disaster Recovery Plan .....	45
2.7.5 Business Continuity Plan .....	45
2.7.6 Flood Emergency Response Plan .....	46
2.7.7 Contingency Plan .....	46
2.7.8 Service Interruption Plan .....	47



2.7.9 Security ..... 48

**3.0 SUPPORT FOR RECOMMENDATIONS** ..... 49

3.1 Construction and Location ..... 49

3.1.1 General ..... 49

3.1.2 Penetrations ..... 49

3.1.3 Cables ..... 49

3.1.4 Insulation ..... 49

3.1.5 Earthquake ..... 49

3.2 Occupancy ..... 50

3.2.1 Data Processing Equipment Rooms ..... 50

3.2.2 Raised Floor and Above-Ceiling Areas Containing Cable ..... 50

3.2.3 Hot/Cold Aisle Containment and Hot Collar Systems ..... 50

3.2.4 Servers, Mainframes, and Supercomputers ..... 50

3.2.5 Quantum Computers ..... 51

3.2.6 Li-Ion Battery Backup Units in Data Processing Equipment Rooms ..... 51

3.2.7 Tape Cartridge Storage ..... 52

3.2.8 Utilities ..... 53

3.3 Protection ..... 60

3.3.1 General ..... 60

3.3.2 Detection ..... 61

3.3.3 Suppression ..... 62

3.4 Equipment and Processes ..... 63

3.4.1 Mobile/Modular Data Center ..... 63

3.4.2 Diagnostic Equipment ..... 64

3.5 Loss History ..... 64

3.5.1 NFPA ..... 64

**4.0 REFERENCES** ..... 64

4.1 FM ..... 64

4.1.1 FM Approvals ..... 65

4.2 Other Standards ..... 65

**APPENDIX A GLOSSARY OF TERMS** ..... 66

**APPENDIX B DOCUMENT REVISION HISTORY** ..... 70

**APPENDIX C PERFORMANCE TEST PROCEDURES FOR VEWF D SYSTEMS** ..... 74

C.1. Objectives ..... 74

C.2. Heated Wire Test ..... 74

**APPENDIX D CLEAN AGENTS** ..... 76

**APPENDIX E TESTING OF POWER ISOLATION DISCONNECT CONTROL SYSTEMS** ..... 77

**APPENDIX F BIBLIOGRAPHY** ..... 78

**List of Figures**

Fig. 2.1. Conceptual layout of data center facility ..... 5

Fig. 2.3.2.2.3. Flowchart to determine the above-floor protection option for the data processing equipment room ..... 11

Fig. 2.3.2.3.5. Flowchart for determining the protection option, below raised floors and above ceiling spaces, for the data processing equipment room ..... 13

Fig. 2.3.2.4.10.A. Conceptual view of cold aisle containment system (Note: Other containment configurations can be used to control the cooling of servers) ..... 15

Fig. 2.3.2.4.10.B. Conceptual view of hot aisle containment system ..... 16

Fig. 2.3.2.4.10.C. Conceptual view of hot collar containment system ..... 16

Fig. 2.3.2.4.10.D. Conceptual view of hot/cold aisle with horizontal air flow without a raised floor ..... 17

Fig. 2.3.2.5.2. Typical server cabinet and rack arrangement ..... 17

Fig. 2.3.2.7.1. Typical configuration of Battery Back-up Units in Distributed Power System ..... 19

Fig. 2.3.2.7.3. Vertical barrier location ..... 19

Fig. 2.3.5.2.3.3. Utility Main Switchgear ..... 22

Fig. 2.4.3.7.1. Very early warning fire detection (VEWFD); air-aspirating type ..... 29

Fig. 2.4.4.2.3.D. Schematic of preaction valve with test discharge line ..... 33

Fig. 3.2.8.1.1.a. Electrical power distribution for a data center (Redundant Distribution) ..... 53

Fig. 3.2.8.1.1.b. Electrical power distribution for a data center (PDU Pairing) ..... 54

Fig. 3.2.8.1.1.c. Uninterruptible power system for a data center) ..... 55  
Fig. E-1. Basic power isolation disconnect control system framework ..... 77

**List of Tables**

Table 2.4.4.2.2. Sprinkler System Operation Sequence ..... 31  
Table 3.2.8.3. Medium and Low Voltages Used in Various Countries ..... 57  
Table 3.2.8.6. Tier Requirements Summary ..... 59  
Table C-2. Heated-Wire Test Parameters ..... 74  
Table D-1. Design Concentrations for Clean Agents ..... 76  
Table D-2. Design Concentrations for Clean Agents with an Energized Electrical Hazard ..... 76

## 1.0 SCOPE

This data sheet contains property loss prevention recommendations for data centers and their critical systems and equipment. This data sheet also identifies the hazards associated with these facilities and recommends risk-mitigation solutions from a property protection and business continuity perspective.

Related facilities covered in this data sheet include network control rooms, broadcast equipment and diagnostic equipment. Where the term “data center” is used in this document, facilities that have similar electronic equipment are also intended.

This data sheet does **not** cover the following:

- Telecommunication and broadcast facilities that use direct current (DC) power; refer to FM Property Loss Prevention Data Sheet 5-14, *Telecommunications*.
- Motor control centers and switchgear rooms; refer to FM Property Loss Prevention Data Sheet 5-19, *Switchgear and Circuit Breakers*.
- Industrial control system (ICS) instrumentation equipment rooms, control centers or process control rooms; refer to FM Property Loss Prevention Data Sheet 7-110, *Industrial Control Systems*.

## 1.1 Hazards

The main hazard associated with data centers and similar facilities is damage to sensitive electronic equipment caused by smoke, liquid from a variety of sources, and natural hazard exposures.

Fire-related hazards include energized equipment and cabling, power supply areas (backup generator fuel systems and UPS batteries) and storage of spare cables (plastics) and other combustible materials. Fire involving energized equipment and cabling will grow slowly, release large amounts of smoke, and cannot be completely extinguished until the power is shut off.

Hazards to the functional operation of a data center include lack of power to data processing equipment support systems (e.g., HVAC).

## 1.2 Changes

**October 2024.** Interim revision. The following changes were made:

- A. Modified the current recommendations to identify data centers should not use polyvinyl chloride (PVC) construction materials (Section 2.2.1).
- B. Added new Appendix E, *Testing of Power Isolation Disconnect Control Systems*, which provides an overview of the integrated system with by-pass that allows for testing the depowering of electrical equipment in the data processing equipment room.

## 2.0 LOSS PREVENTION RECOMMENDATIONS

### 2.1 Introduction

A data center consists of equipment room(s), utilities, and support infrastructure. See Figure 2.1 for a conceptual layout.

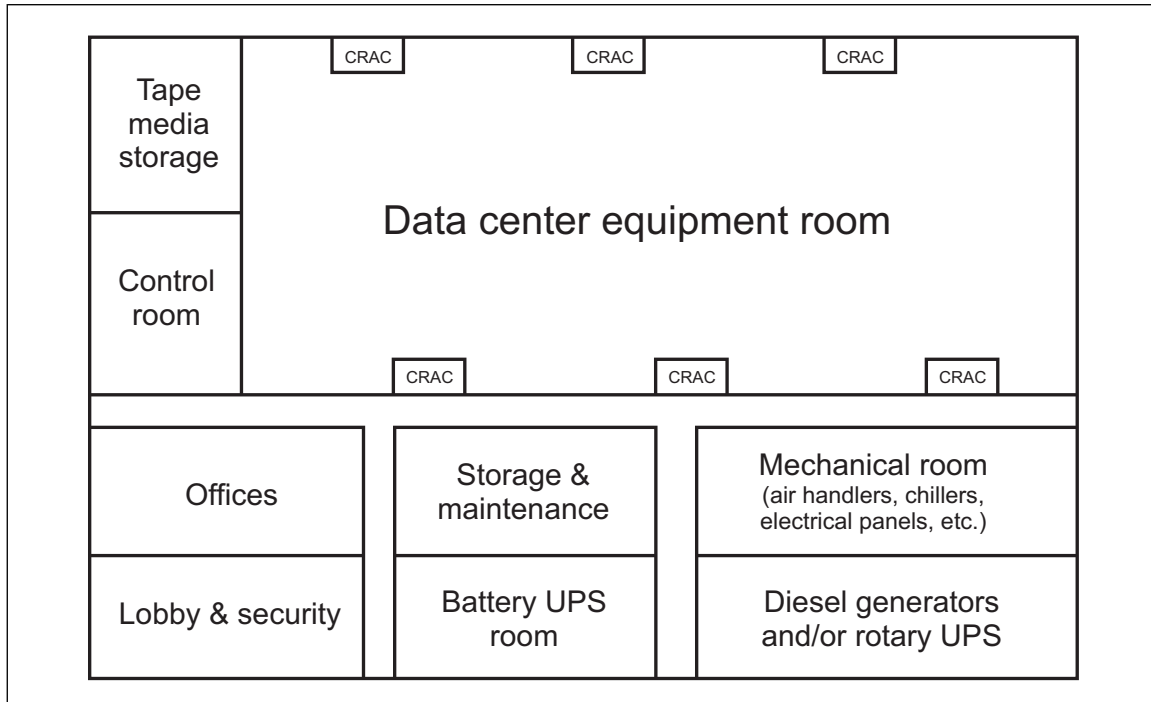

Fig. 2.1. Conceptual layout of data center facility

The following represents FM's loss prevention recommendations for new data centers and related facilities. Particular attention should be given to using noncombustible construction materials, plenum-rated wires and cables, plenum-rated raceways and routing assemblies, non-fire-propagating hot/cold aisle containment materials, and noncombustible filters and insulation. Fire detection and suppression options are also provided.

Use FM Approved equipment, materials, and services whenever they are applicable and available. For a list of products and services that are FM Approved, see the *Approval Guide*, an online resource of FM Approvals.

## 2.2 Construction and Location

### 2.2.1 General

2.2.1.1 Construct data centers of noncombustible materials. Plastic materials, including those of fire-retardant composition, can produce large quantities of smoke and should not be used.

2.2.1.2 If plastic materials are used, provide materials **FM Approved to:**

A. FM Approval Standard 4882, *Class 1 Interior Wall and Ceiling Materials or Systems for Smoke Sensitive Occupancies*

B. FM Approval Standard 4884, *Panels Used in Data Processing Center Hot and Cold Aisle Containment Systems*

2.2.1.2.1 Do not use polyvinyl chloride (PVC) materials for construction of data centers.

2.2.1.3 Protect data centers against external fire exposure, such as from green wall installations, waste collection, fuel tanks and fuel unloading stations. Do not allow combustible material to expose the building

or the air intake(s) for the building. Provide blank masonry walls or other suitable protection when an unfavorable exposure or the potential for vandalism from outside the building exists. (Refer to Data Sheet 1-20, *Protection Against Exterior Fire Exposure*.)

2.2.1.3.1 Protect data centers from exterior exposure in accordance with the following:

- Transformers in accordance with Data Sheet 5-4, *Transformers*.
- Diesel generators in accordance with Data Sheet 5-23, *Design and Protection for Emergency and Standby Power Systems*.
- Diesel fuel tanks and unloading stations in accordance with Data Sheet 7-88, *Outdoor Ignitable Liquid Storage Tanks*.

2.2.1.4 For high rise data centers, construct the building in accordance with Data Sheet 1-3, *High-Rise Buildings*.

2.2.1.5 For multi-story (non-high rise) data centers, construct the building in accordance with Data Sheet 1-3, *High Rise Buildings*, for the following:

- Fire resistance of building elements
- Protection of openings in floors
- Protection of penetrations

2.2.1.5.1 Do not locate data centers in multistory buildings that have inadequately protected or unprotected areas of the building.

2.2.1.6 Provide prevention and mitigation associated with a liquid release and the potential damage in accordance with Data Sheet 1-24, *Protection Against Liquid Damage in Light-Hazard Occupancies*.

2.2.1.7 Locate data centers so they are not exposed to damage from any hazardous process, storage, corrosive or ignitable liquid or vapor, industrial pollutants, or mechanical equipment such as overhead cranes.

2.2.1.8 Provide supervision of the data center to prevent unauthorized access to the premises and assets in accordance with Data Sheet 9-1, *Supervision of Property*.

## 2.2.2 Walls

2.2.2.1 Provide one-hour fire-rated interior walls, partitions, and floors in accordance with Data Sheet 1-21, *Fire Resistance of Building Assemblies*, for all of the following:

- data processing equipment rooms
- battery power rooms, uninterruptible power supply (UPS) rooms
- network/fiber optic rooms

2.2.2.2 Provide fire-rated interior walls, partitions, and floors for power equipment rooms (standby generator and AC power) in accordance with Data Sheet 5-23, *Design and Protection for Emergency and Standby Power Systems*.

2.2.2.3 Have fire-rated interior walls built from the structural floor of the room to the structural floor above (or to the roof).

2.2.2.4 Protect openings in fire walls, fire partitions and floors in accordance with Data Sheet 2-0, *Installation Guidelines for Automatic Sprinklers*.

2.2.2.5 Use the limiting factors in Data Sheet 1-42, *MFL Limiting Factors*, to limit the maximum exposure from property loss and business interruption. Provide particular consideration of these recommendations to campus style data center locations having multiple data center buildings on the premises of the campus.

## 2.2.3 Doors and Windows

2.2.3.1 Minimize interior windows and doors to the data processing equipment room. For essential interior windows and doors, use tempered or wired glass for windows and minimum 3/4 hour fire-rated doors.

2.2.3.2 If doors are held open intermittently or permanently, provide an electromechanical or electromagnetic holding mechanism interlocked to close the door on smoke detector actuation.

### 2.2.4 Penetrations

2.2.4.1 Seal openings in fire-rated floors and walls through which ducts, pipes, wires, and cables pass using an FM Approved or listed penetration seal with a fire-resistance rating equivalent to the rating of the wall or floor.

2.2.4.2 Provide a leakage-rated penetration seal with a rating as low as possible, but not exceeding 7 ft<sup>3</sup>/min/ft<sup>2</sup> (2.1 m<sup>3</sup>/min/m<sup>2</sup>) in addition to the fire-resistance rating for equipment room penetrations (see Section 3.1.2).

2.2.4.3 When new construction or modifications are in progress, install temporary FM Approved fire-stop penetration seals (e.g., bricks, plugs, cushions) for protection when work is stopped at night and during weekends.

2.2.4.4 Seal openings in fire-rated floors and walls through which HVAC duct(s) pass with an FM Approved fire damper that has a fire-resistance rating equivalent to the rating of the wall or floor.

2.2.4.5 Provide smooth or protected electrical cable openings in floors (e.g., grommets, cable glands) to prevent damage to the cables.

### 2.2.5 Ceilings

2.2.5.1 Construct suspended ceilings of Class I materials; see Data Sheet 1-12, *Ceilings and Concealed Spaces*.

2.2.5.2 Limit the maximum height of ceilings in data centers to 30 ft (9 m). (See Section 2.4.4.2.1 and Section 3.3.3.1.)

### 2.2.6 Floors

2.2.6.1 Construct floors, raised floors, and structural supporting members for raised floors of noncombustible materials.

### 2.2.7 Cables

2.2.7.1 Provide all grouped cables and cable trays (power and data) in accordance with Data Sheet 5-31, *Cable and Bus Bars*, in addition to the following recommendations in this section.

2.2.7.2 Use communication and data cable (e.g., coaxial and fiber optic) and power cables that meet one of the following criteria:

- A. FM Approved Class Number 3972; Group 1 or Group 1-4910
- B. Plenum rated cable listed to Underwriters Laboratories (UL) Standard 910
- C. Cable that has maximum flame spread distance of 5 ft (1.5m) or less tested in accordance with NFPA 262.

2.2.7.3 When communication, data and power cables cannot be provided in accordance with Section 2.2.7.2, provide protection for propagating and combustible materials in accordance with Section 2.4.4.2, Section 2.4.4.3 and Section 2.4.4.4.

2.2.7.4 Provide power cables separate from communication/data cables by keeping the power cables in an independent cable tray/raceway or routing assembly.

2.2.7.5 Remove abandoned or routine spare cables that are not in service and are not intended for future service.

### 2.2.8 Cable Raceways and Routing Assemblies

2.2.8.1 Use cable raceways and routing assemblies made of noncombustible materials.

2.2.8.2 When cable raceway and routing assemblies must be constructed of plastic, use one of the following:

- A. FM Approvals 4910 specification-tested plastics listed in the Building Materials section of the *Approval Guide* (FM4910 plastics), or
- B. Plenum-rated plastic raceways listed to Underwriters Laboratory (UL) Standard 2024.

### 2.2.9 Insulation

2.2.9.1 Provide building insulation and elastomeric materials installed on the building and on the floor beneath a raised floor in accordance with Data Sheet 1-57, *Plastics in Construction*.

2.2.9.2 Provide pipes and ducts using insulation with one of the following:

- A. Noncombustible insulating materials (e.g., foil-wrapped fiberglass or mineral fiber wool), or
- B. FM Approved insulation (Approved to FM Approvals Standard 4924)

### 2.2.10 Earthquake

If the facility is located in FM 50-year through 500-year earthquake zones as defined in Data Sheet 1-2, *Earthquakes*, adhere to the recommendations in this section.

2.2.10.1 For new facilities (and for existing facilities at significant risk), have a seismic risk analysis conducted by a consulting firm specializing in earthquake design and evaluation. Consider all aspects of facility construction design, as well as process and building service equipment for local code compliance and applicable recommendations of Data Sheet 1-2, *Earthquakes*, and components and systems in the scope of Section 2.2.10.

2.2.10.2 Use construction and protection components that are listed in the *Approval Guide* for seismic protection whenever possible.

2.2.10.3 Provide seismic protection adequate to resist the forces specified in Data Sheet 1-2, *Earthquakes*, or the local building code, whichever is more stringent, for the items identified in Sections 2.2.10.4 through 2.2.10.7.

2.2.10.4 Provide seismic bracing and anchoring of all fire protection system components, piping, pumps, cylinder banks, etc. per Data Sheet 2-8, *Earthquake Protection for Water-Based Fire Protection Systems*. This recommendation applies to sprinklers, water mist, clean agent and hybrid fire protection systems.

2.2.10.5 Provide seismic anchoring and bracing for data processing equipment (e.g., server racks, mainframes, automated tape libraries).

2.2.10.5.1 Seismic isolation (e.g., free-rolling-base isolator pads under servers) of electronic equipment is an acceptable alternative to anchoring if a detailed seismic analysis is provided for the specific location.

2.2.10.6 Provide seismic bracing for raised floor systems, including mechanical anchors (e.g., bolts) at the base of the raised floor support pedestals to the structural floor, and separate bracing to resist lateral movement of the access floor (e.g., angled cross bracing from the structural floor to the access floor supports).

2.2.10.7 Provide seismic bracing of data processing equipment support systems (with the performance goal of maintaining uninterrupted data equipment system operations during and after an earthquake), including but not limited to, the following:

- A. HVAC: air handling units, liquid piping (e.g., chilled water, condensing water, condensate drains, refrigerant), cooling towers, pumps, etc.
- B. Plumbing and process piping conveying liquids (e.g., potable water, roof drains, pure water, etc.) located in or above data processing equipment spaces and that cannot be relocated.
- C. Electrical power and data raceways: single conduit 2-1/2 in. (6.35 cm) or greater diameter, cable raceways, cable trays and conduit racks where the total load is more than 10 lb/ft (15 kg/m). No additional seismic protection is needed on these items if they are supported by hangers 12 in. (0.3 m) or less in length.
- D. Uninterruptible power systems (UPS), including restraint of battery racks and batteries to the racks.
- E. Emergency power generation systems: generators, fuel tanks and fuel piping.
- F. Electrical power systems: switchgear, motor control centers, transformers and bus bars.



### 2.2.11 Windstorm

2.2.11.1 Design buildings, roof-mounted equipment, and ground-mounted equipment for wind forces in accordance with Data Sheet 1-28, *Wind Design*, and Data Sheet 1-29, *Roof Deck Securement and Above-Deck Roof Components*.

2.2.11.2 Design towers in accordance with Data Sheet 1-8, *Antenna Towers and Signs*.

2.2.11.3 Minimize the number of exterior windows and doors to the data center. When required, provide them in accordance with Data Sheet 1-28, *Wind Design*.

### 2.2.12 Flood/Storm Water Runoff

2.2.12.1 Select a building site that is above the predicted 0.2% annual exceedance (500-year) flood elevation and includes 1 to 2 ft (0.3 to 0.6 m) of freeboard. Ensure the building site is at least 500 ft (152 m) from direct wave impacts and/or high flood-flow velocities (i.e., above 7 fps [2 m/s]). (See Data Sheet 1-40, *Flood*.)

2.2.12.2 Protect data centers, critical systems, and equipment of the facility and related facilities against storm water runoff in accordance with Data Sheet 1-40, *Flood*.

2.2.12.3 Provide dedicated water-removal capability for all below-grade areas subject to flooding from storm water runoff or sewer backup. This drainage should include backwater valves or other devices to prevent backflow during an extreme rainfall event.

2.2.12.3.1 Provide automatic-starting sump pumps with an alarm to a constantly attended area.

2.2.12.3.2 Connect electric-powered sump pumps to the backup power supply.

## 2.3 Occupancy

This section summarizes typical areas of a data center and the general protection recommendations that apply to these areas. Guidance is provided for attributes that can impact the effectiveness of fire protection and to identify specifications (e.g., air flow, cable type) that permit that protection option.

Recommendations on how to provide specific detection and protection for the various equipment and occupancy areas in a data center are included in Section 2.4, Protection.

### 2.3.1 General Data Center Areas (Offices, Lobby, Security)

2.3.1.1 Provide fire detection in areas that are adjacent to the data processing equipment room and in rooms containing systems or equipment critical to the continued operation of the data processing facility (e.g., offices, hallways, utility rooms, loading docks) in accordance with Data Sheet 5-48, *Automatic Fire Detection*.

2.3.1.2 Provide automatic sprinkler protection throughout all of the data center building for the appropriate hazard classification in accordance with FM Property Loss Prevention Data Sheet 3-26, *Fire Protection for Nonstorage Occupancies*.

2.3.1.3 Provide fire alarm systems in accordance with Data Sheet 5-40, *Fire Alarm Systems*.

### 2.3.2 Data Processing Equipment Room

#### 2.3.2.1 General

Automatic water-based fire protection is recommended to provide the highest possible level of flexibility for protection of the various hazards.

2.3.2.1.1 Limit the use of paper and other combustibles in the data processing equipment room to a “scant” quantity. (Scant in this context means a quantity and distribution of combustibles that, in a worst-case fire scenario, could be successfully extinguished using only one portable fire extinguisher.)

2.3.2.1.2 Do not store cartons and packing materials from equipment or plastic cassettes within the data processing equipment room.

2.3.2.1.3 Establish a formal manual power isolation plan in accordance with Section 2.3.5.4 and Section 2.7.3 regardless of the type of fire protection being provided.

### 2.3.2.2 Data Processing Equipment Room (Above Floor)

2.3.2.2.1 Provide FM Approved very early warning fire detection (VEWFD; see Appendix A, Glossary of Terms) in accordance with Section 2.4.3 for the data processing equipment room and HVAC return air systems.

2.3.2.2.2 Where an enhanced level of detection is desired for critical business operations and/or in support of manual power isolation, install VEWFD directly in equipment racks or cabinets.

2.3.2.2.3 Use the flowchart in Figure 2.3.2.2.3 to determine which fire protection option can be provided to protect the data processing equipment room.

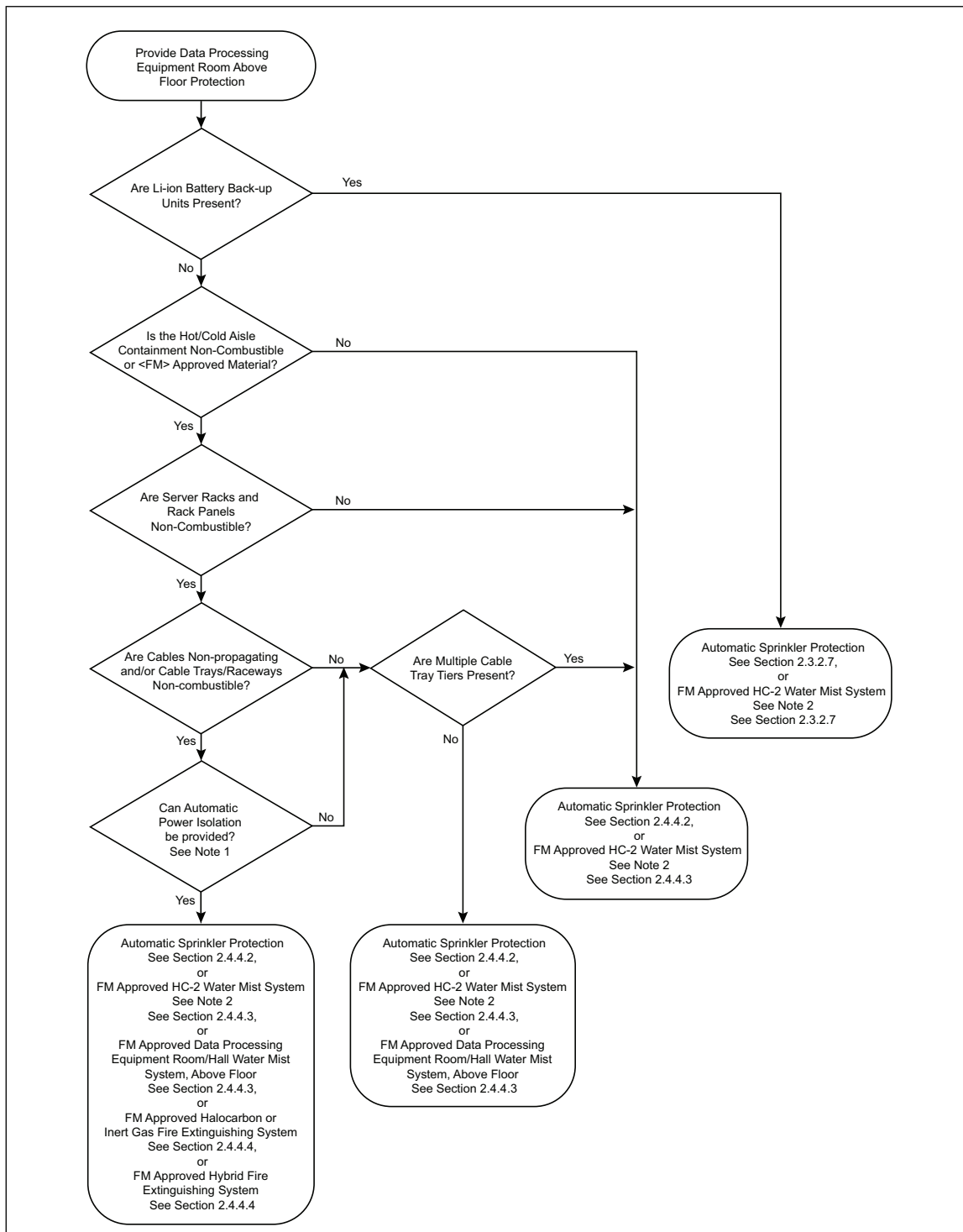

Fig. 2.3.2.2.3. Flowchart to determine the above-floor protection option for the data processing equipment room

**Notes for Fig. 2.3.2.2.3:**

**Note 1.** Automatic power isolation as recommended in Section 2.4.4.4.1 is preferred to prevent reignition and smoke recirculation. Alternatively, a manual power isolation option can be considered when provided in accordance with Section 2.3.5.4.1. When automatic or manual power isolation cannot be provided, use one of the alternative, water-based protection options outlined in the flowchart in Figure 2.3.2.2.3.

**Note 2.** Currently (as of January 2024), no FM Approved HC-2 water mist systems are available for this application category identified in the FM Approval Class 5560 Standard. The FM *Approval Guide* should be referenced for the most current listing.

**2.3.2.3 Raised Floor or Above-Ceiling Spaces Containing Combustibles (Concealed Spaces)**

2.3.2.3.1 Provide or extend FM Approved very early warning fire detection (VEWFD) from the data processing equipment room into spaces below the raised floor or in above-ceiling spaces that contain cables in accordance with Section 2.4.3.

2.3.2.3.2 Smoke detection systems below the raised floor space may be omitted under either of the following conditions:

- A. If only FM Approved Group 1, Group 1-4910, or UL-listed plenum-rated cables are present.
- B. If VEWFD is provided at the air return for forced air re-circulated from below the raised floor into the room.

2.3.2.3.3 Provide an automatic fire protection system in the following places:

- A. Below a raised floor area or above-ceiling spaces with combustible construction or insulation.
- B. Below noncombustible raised floors or in above-ceiling spaces when propagating cables are present.

2.3.2.3.4 Fire protection for cables below raised floors or above-ceiling spaces is not needed when the types of cables identified in Section 2.2.7.2 are used.

2.3.2.3.5 When fire protection is to be provided, use the flowchart in Figure 2.3.2.3.5 to determine which fire protection option can be provided for protecting combustibles in concealed spaces (e.g., below the raised floor, above ceiling spaces or ceiling air plenum, in the data processing equipment room).

In the context of this flowchart, concealed spaces are either below the raised floor, above ceiling spaces or ceiling air plenum, or in the data processing equipment room.

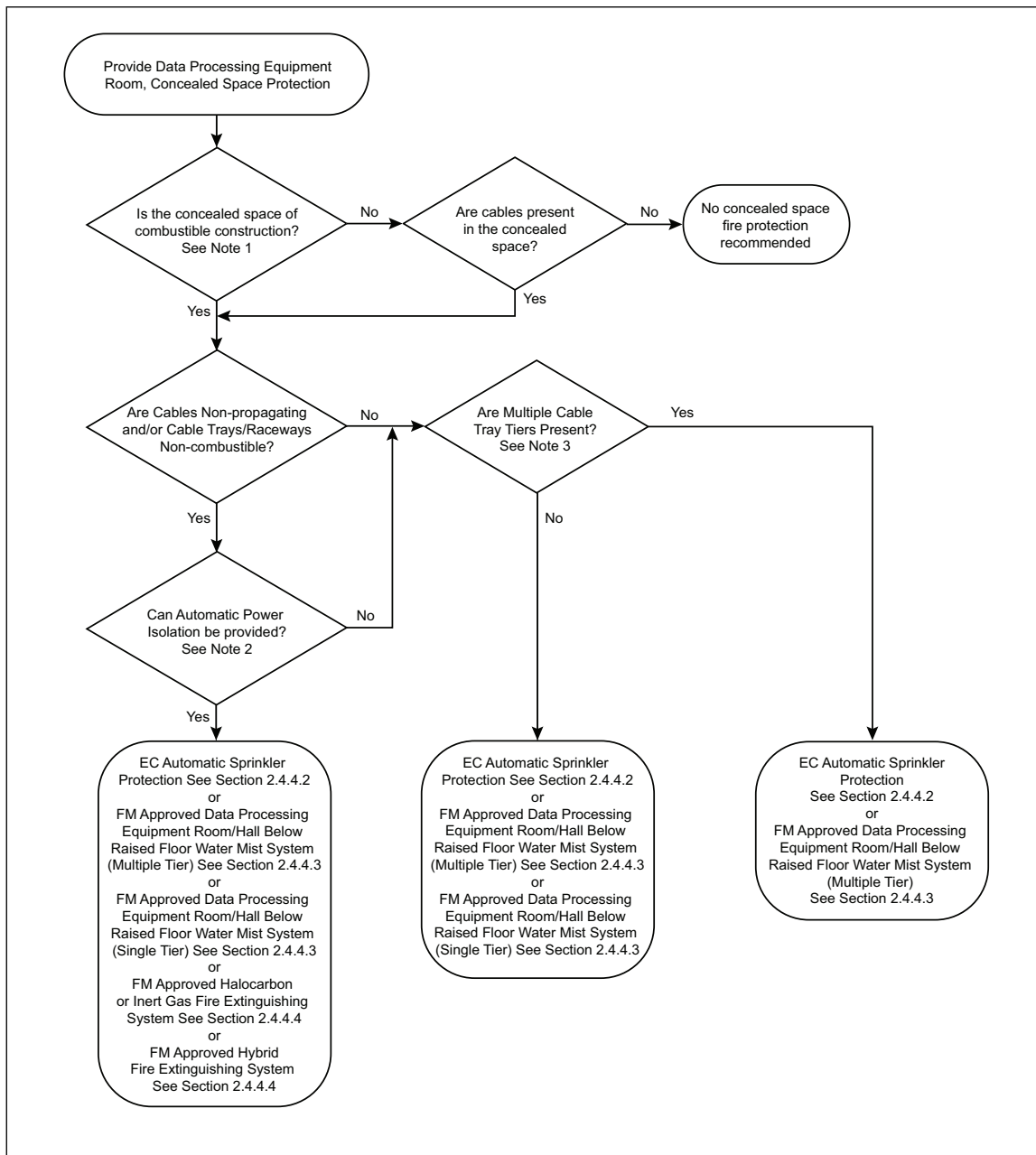

Fig. 2.3.2.3.5. Flowchart for determining the protection option, below raised floors and above ceiling spaces, for the data processing equipment room

**Notes for Fig. 2.3.2.3.5:**

**Note 1.** See Section 2.3.2.3.8 when combustible elastomeric materials and floor supports beneath a raised floor are to be provided.

**Note 2.** Automatic power isolation as recommended in Section 2.4.4.4.1 is preferred to prevent reignition and smoke recirculation. Alternatively, a manual power isolation option can be considered when provided in accordance with Section 2.3.5.4.1. When automatic or manual power isolation cannot be provided, use one of the alternative protection options.

**Note 3.** The number of allowable tiered cable trays for water mist systems is identified in the FM Approval Guide listing.

2.3.2.3.6 Provide one of the fire protection systems, as determined in Figure 2.3.2.3.5, to protect the combustibles under the raised floor or above ceiling spaces in the data processing equipment room.

2.3.2.3.7 Actuate the fire protection system by smoke detection in accordance with Section 2.4.3.

2.3.2.3.8 Do not install exposed combustible elastomeric materials onto the floor and floor supports to prevent condensation build-up beneath raised floors.

2.3.2.3.8.1 When the installation of combustible elastomeric materials on the floor and floor supports beneath a raised floor is unavoidable, provide protection in accordance with the relevant recommendations in Data Sheet 1-57, *Plastics in Construction*.

2.3.2.3.9 Provide a ready means of access in proximity to the detectors, sprinklers, and fire extinguishing system nozzles in the raised floor or above-ceiling space for inspection and maintenance.

#### 2.3.2.4 Hot/Cold Aisle Containment and Hot Collar Systems

2.3.2.4.1 Provide containment systems constructed of one of the following (listed in order of preference):

A. Noncombustible materials

B. FM Approved plastic containment panels listed as Class 4884, *Panels Used in Data Processing Center Hot and Cold Aisle Containment Systems*.

2.3.2.4.2 If a solid containment ceiling is installed as a portion of the hot/cold aisle containment system, provide one of the following:

A. Adequate automatic fire protection (e.g., sprinklers, water mist, clean agent or hybrid) beneath the ceiling (designed per Section 2.4.4 and 2.3.2.4.4)

B. FM Approved (Class 4651) drop-out ceiling panels in conjunction with adequate automatic fire protection at ceiling level in the data processing equipment room. Install drop-out ceiling panels in accordance with Data Sheet 1-12, *Ceilings and Concealed Spaces*, and the following:

1. Use quick-response sprinklers or quick-response automatic water mist nozzles installed at ceiling level.
2. Limit the height of the drop-out ceiling panels above the floor to 15 ft (4.5 m).
3. Limit the distance between the drop-out ceiling panels and the sprinklers located above the ceiling to 20 ft (6.0 m).
4. Limit the distance between the drop-out ceiling panels and the automatic water mist nozzle located at ceiling level to the maximum ceiling height in the water mist system's FM Approval listing.

2.3.2.4.3 If containment curtains or other vertical partitions form part of the containment system or hot collar in such a way that the automatic fire protection at ceiling level can be obstructed, do one of the following:

A. Locate the partitions so they do not impede the discharge of the protection system for the contained area.

B. Provide additional discharge devices (e.g., automatic sprinklers, water mist nozzles, clean agent nozzles or hybrid nozzles) for the automatic fire protection (designed per Section 2.4.4 and 2.3.2.4.4) in the contained area.

2.3.2.4.4 When protection is to be supplied within the containment system, provide the following:

A. FM Approved quick-response (QR) sprinklers with a minimum density of 0.2 gpm/ft<sup>2</sup> (8 mm/min) over:

1. 2500 ft<sup>2</sup> (230 m<sup>2</sup>) for a wet system configuration, or
2. 3500 ft<sup>2</sup> (320 m<sup>2</sup>) for a dry system configuration

B. FM Approved quick-response automatic water mist nozzles arranged in accordance with their FM Approval listing.

C. Sprinkler deflector or nozzle distance from the ceiling:

- Minimum: 1.75 in. (44 mm)
- Maximum: 4 in. (100 mm)

2.3.2.4.4.1 If a grated ceiling is installed as part of the hot aisle containment system, provide a maximum spacing of 4 ft (1.2 m) between sprinklers or an automatic water mist nozzle at the ventilation ceiling and plenum interface. (See Figure 2.3.2.4.10.B.)

2.3.2.4.5 Do not use the following containment devices as alternatives to providing sprinklers below the ceiling or within the containment system:

- A. Containment panels mounted with fusible links
- B. Automatic releases on curtains and panels

2.3.2.4.6 When hot collar systems are used (see Figure 2.3.2.4.10.C), evaluate sprinkler locations for obstructions in accordance with Data Sheet 2-0, *Installation Guidelines for Automatic Sprinklers*.

2.3.2.4.7 If the data processing equipment room and exhaust/air return (see Section 2.3.2.2) has been provided with an FM Approved VEVFD system, no detection is needed beneath a solid cold aisle containment ceiling.

2.3.2.4.8 Arrange and install detection in the hot aisle containment system or hot collar in accordance with the manufacturer's design guide and/or application guide for this specific application.

2.3.2.4.9 Verify the FM Approved detection within the containment system (hot aisle) is listed for the ambient temperature of its location.

2.3.2.4.10 If a halocarbon and inert gas (clean agent) or hybrid (inert gas and water) fire extinguishing system is installed for the containment system, provide the following:

- A. The clearance of the discharge nozzle(s) from the sidewall(s) of the containment system, provided in accordance with the fire extinguishing system manufacturer's design, installation and operation manual included with the FM Approval listing.
- B. The proper design concentration within the volume of the containment system.
- C. The proper design concentration surrounding the containment system(s).
- D. A halocarbon and inert gas (clean agent) or hybrid (water and inert gas) fire extinguishing system designed in accordance with Section 2.4.4.4.

Figures 2.3.2.4.10.A and 2.3.2.4.10.B provide conceptual views of typical cold aisle and hot aisle containment systems with vertical air flow and typical sprinkler/nozzle placement. Figure 2.3.2.4.10.C provides a conceptual view of a hot collar containment system with vertical air flow and typical sprinkler/nozzle placement. Figure 2.3.2.4.10.D provides a conceptual view of a hot and cold aisle containment systems for horizontal air flow with no raised floor.

**Note:** Other containment configurations can be used to control the cooling of servers.

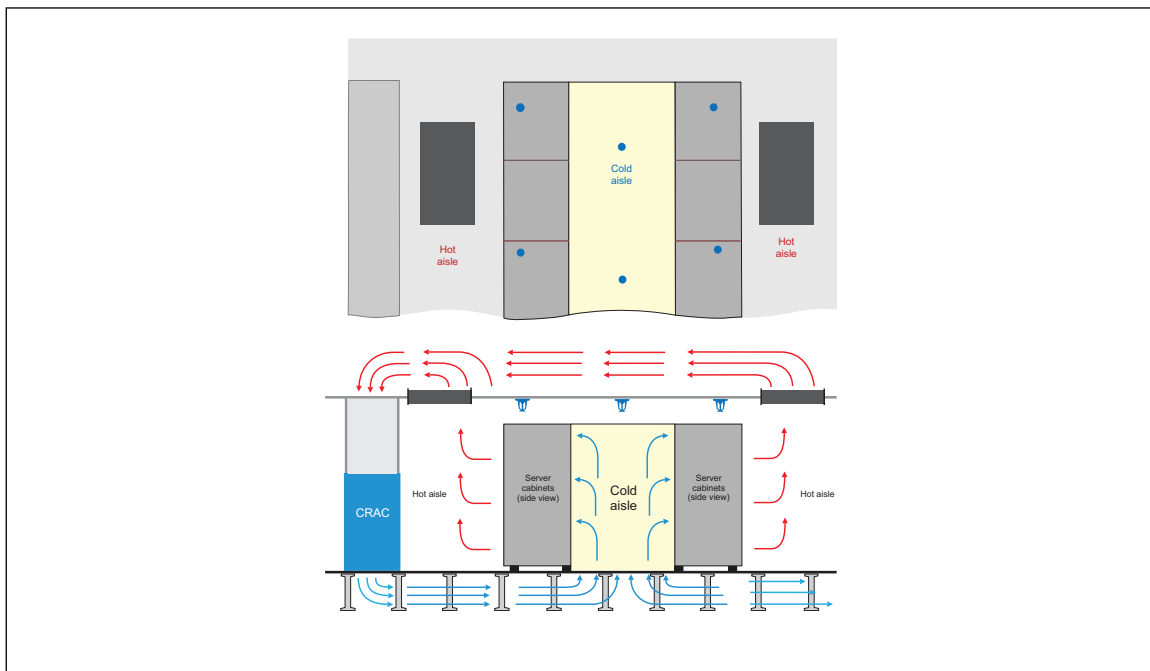

Fig. 2.3.2.4.10.A. Conceptual view of cold aisle containment system (Note: Other containment configurations can be used to control the cooling of servers)

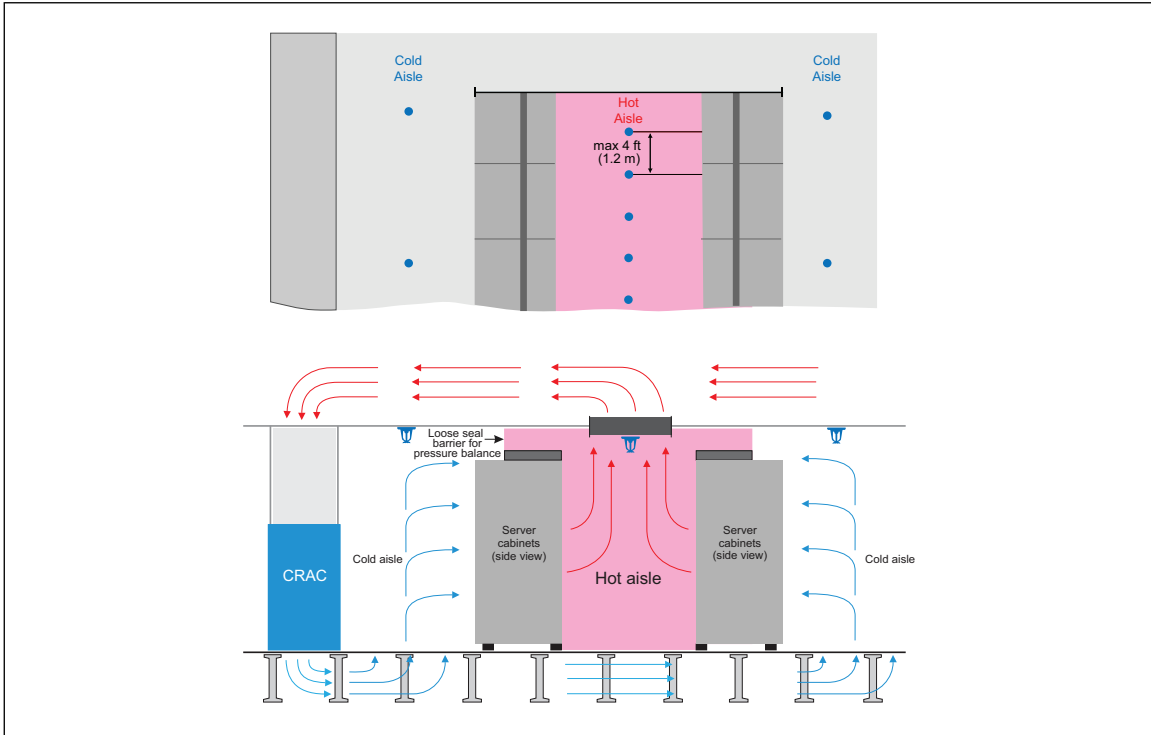

Fig. 2.3.2.4.10.B. Conceptual view of hot aisle containment system

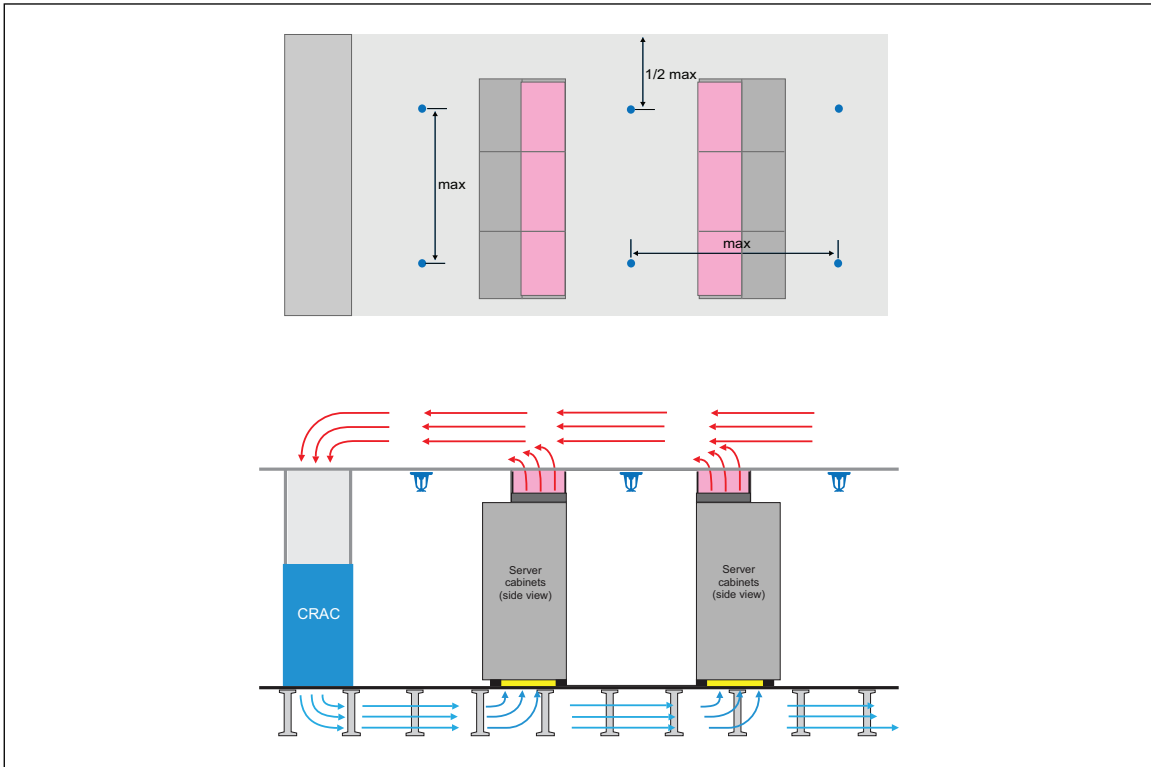

Fig. 2.3.2.4.10.C. Conceptual view of hot collar containment system



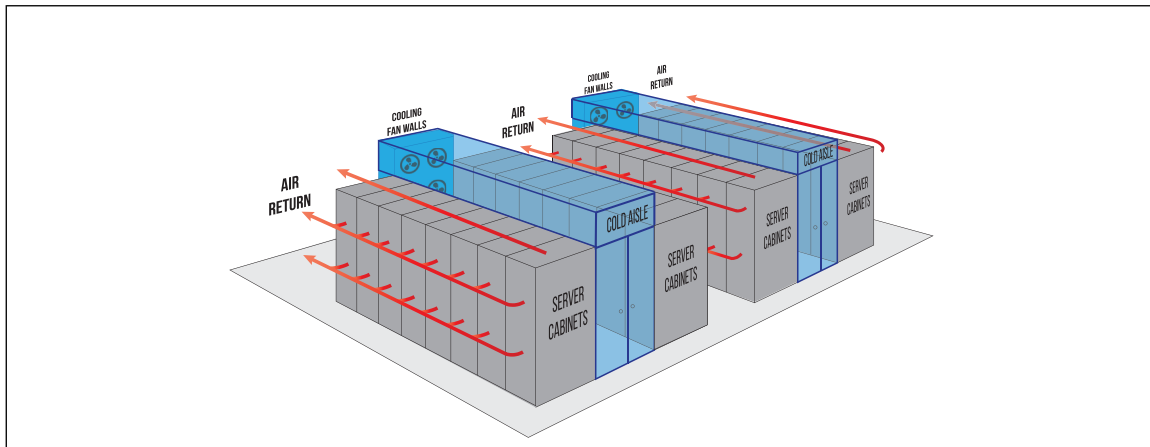

Fig. 2.3.2.4.10.D. Conceptual view of hot/cold aisle with horizontal air flow without a raised floor

### 2.3.2.5 Equipment – Servers, Mainframes, Supercomputers Computers

2.3.2.5.1 Use equipment and replacement parts listed to safety standards for their intended purpose by a nationally recognized testing laboratory (NRTL).

2.3.2.5.2 Provide server enclosures (e.g., cabinets) and racks constructed of noncombustible materials. See Figure 2.3.2.5.2 for a typical server cabinet and rack arrangement.



Fig. 2.3.2.5.2. Typical server cabinet and rack arrangement

2.3.2.5.3 Provide blanking plates constructed of one of the following (listed in order of preference) for empty server slots when used to route air flow in the equipment racks or hot/cold aisle containment system:

- A. Metal
- B. Noncombustible material
- C. Plastic material listed to the FM Approval Standard Class 4884

2.3.2.5.4 If data processing equipment is liquid-cooled or uses immersion cooling, provide an alarm to indicate fluid leakage in accordance with Data Sheet 1-24, *Protection Against Liquid Damage in Light-Hazard Occupancies*.

2.3.2.5.5 If a liquid is used for lubrication and/or cooling of the server equipment, use one of the following:

- A. A container of sealed construction
- B. A non-ignitable liquid
- C. Vent/pressure relief to a safe location for a container that is pressurized.

2.3.2.5.6 Provide proper grounding for equipment in accordance with Data Sheet 5-19, *Switchgear and Circuit Breakers*, Data Sheet 5-20, *Electrical Testing* and the manufacturer's instructions.

#### **2.3.2.5.7 Protection of Servers, Mainframes**

2.3.2.5.7.1 When reducing equipment damage from an incipient fire to minimum possible levels is essential, or to facilitate a quicker return to service, provide an FM Approved halocarbon or inert gas (clean agent) fire extinguishing system with VEWFD detection to protect the data equipment within the data processing equipment room. This approach supplements the automatic sprinkler or water mist system protection for the data processing equipment room.

2.3.2.5.7.2 Install the halocarbon or inert gas (clean agent) fire extinguishing system in accordance with the applicable recommendations in Section 2.4.4.4.

2.3.2.5.7.3 Install FM Approved very early warning fire detection (VEWFD) to actuate the halocarbon or inert gas (clean agent) fire extinguishing system in accordance with Section 2.4.3.

#### **2.3.2.6 Quantum Computers**

See Section 3.2.5 for information on Quantum computers.

#### **2.3.2.7 Li-ion Battery Back-up Units for Distributed Power Systems**

2.3.2.7.1 Where Li-ion battery back-up units (BBU) are installed in a server rack as a distributed power system, the recommendations in this section are to be applied if the following conditions exist:

- A. Maximum power capacity of 20 kWh per server rack as a distributed power configuration. (Refer to Section 3.2.6 for calculating power capacity.)
- B. No more than two shelves containing BBU modules located together in the same area of the rack. (See Figure 2.3.2.7.1 for typical configuration.)
- C. Aisle spacing between server rows is a minimum of 4 ft (1.2 m).
- D. Ceiling height is a maximum 30 ft (9 m). (Refer to Section 3.3.3.1.)
- E. No limitation on the building/room size (area in ft<sup>2</sup>/m<sup>2</sup>).

2.3.2.7.2 Server racks with distributed Li-ion battery back-up units (BBU) exceeding the maximum capacity of 20 kWh per rack should be considered Energy Storage Systems (ESS); and the recommendations identified in Data Sheet 5-33, *Lithium-Ion Battery Energy Storage Systems*, should be followed.

2.3.2.7.3 Provide vertical barriers in all server rack rows where Li-ion distributed power systems are used or expected to be used, regardless of the power capacity. Provide vertical barriers as follows (see Figure 2.3.2.7.3).

2.3.2.7.3.1 Locate vertical barriers after every third rack along the entire length of server rows.

2.3.2.7.3.2 Use a minimum 20-gauge (0.9 mm) solid sheet metal for the vertical barriers on the side of every third rack to limit the fire spread.

2.3.2.7.3.3 Completely cover the side of the server rack with the barrier to fit the rack side profile.

2.3.2.7.3.4 Install the barrier in a way that will not reduce the effectiveness of the hot/cold aisle air flow cooling arrangement (i.e., kept to the side frame profile of the server racks).

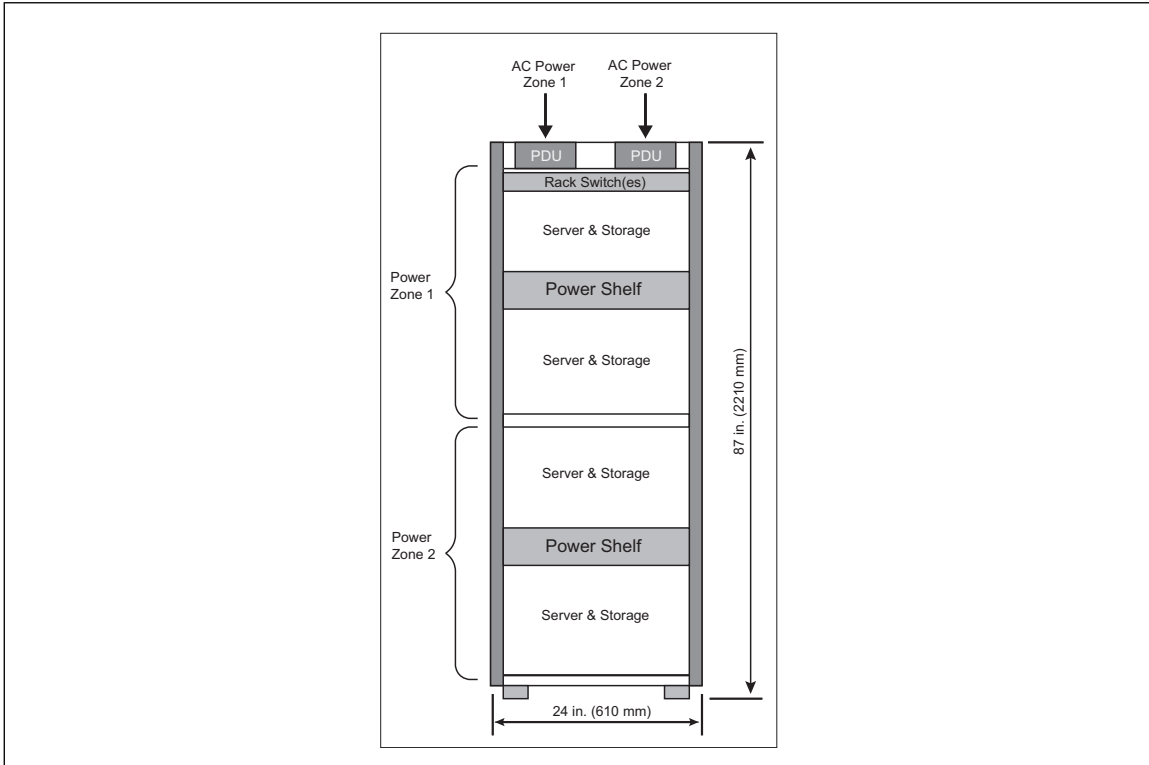

Fig. 2.3.2.7.1. Typical configuration of Battery Back-up Units in Distributed Power System

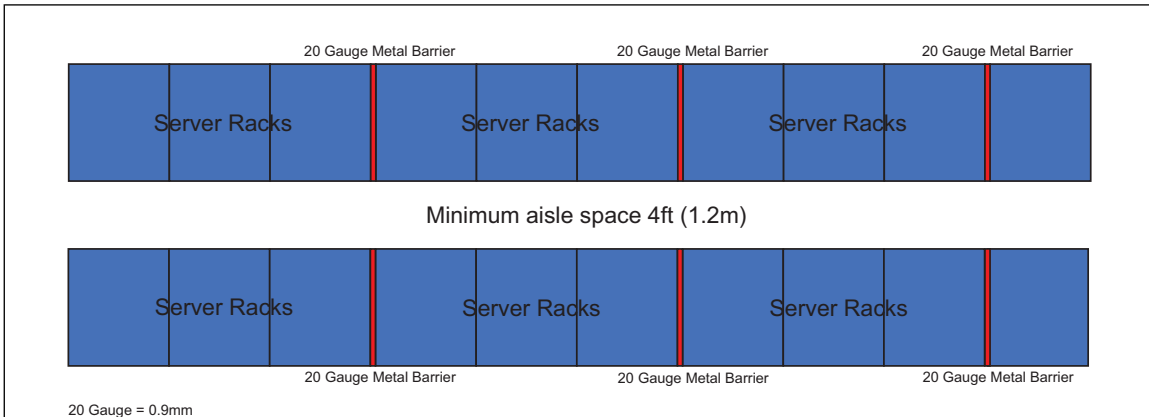

Fig. 2.3.2.7.3. Vertical barrier location

2.3.2.7.4 Provide one of the following automatic protection options throughout all building areas associated with this hazard:

A. FM Approved quick-response (QR) sprinklers in accordance with Data Sheet 2-0, *Installation Guidelines for Automatic Sprinklers*, and having the following specifications:

1. Minimum density 0.2 gpm/ft<sup>2</sup> (8 mm/min). Sprinkler deflector distance from the ceiling (min: 1.75 in. [44 mm]; max: 4 in. [100 mm]).
2. For wet, non-interlock or single interlock preaction systems, use a demand area of 2500 ft<sup>2</sup> (230 m<sup>2</sup>).
3. For double interlock preaction systems, use a demand area of 3,500 ft<sup>2</sup> (320 m<sup>2</sup>).

4. Provide a maximum linear spacing of 12 ft (3.6 m) and area spacing of 144 ft<sup>2</sup> (13.4 m<sup>2</sup>), or a reduced spacing and area for clearance from obstructions, in accordance with Data Sheet 2-0, *Installation Guidance for Automatic Sprinklers*.

B. Use FM Approved automatic water mist systems with the following specifications:

1. Approved for protection of non-storage, Hazard Category (HC-2) occupancies.
2. Provided in accordance with Sections 2.4.4.3.2 through 2.4.4.3.9.

2.3.2.7.5 Provide a water supply duration of 60 minutes.

2.3.2.7.6 Do not use halocarbon or inert gas (clean agent) fire extinguishing systems to provide protection for data processing equipment rooms with distributed Li-ion battery back-up units. (See Section 3.2.6)

### 2.3.2.8 Tape Cartridge Storage

#### 2.3.2.8.1 Automated Tape Cartridge Storage Units

A fire inside any automated tape cartridge storage unit can cause significant nonthermal damage to electronic equipment in the surrounding space.

2.3.2.8.1.1 Use tape cartridge cassettes constructed of one of the following:

- A. Noncombustible materials
- B. Plastics that have been specification-tested to FM Approval Standard 4910. Specification-tested products are listed in the Building Material section of the *Approval Guide*.

2.3.2.8.1.2 When tape cartridges are constructed of combustible materials, provide all of the following:

- A. An FM Approved very early warning fire detection (VEWFD) system within the cabinet in accordance with Section 2.4.3.
- B. An interlock with smoke detection to de-energize the electrical service to the cabinet in accordance with Section 2.7.3.
- C. Protection provided by one of the following within each unit:
  1. Automatic sprinkler protection per Section 2.4.4.2 in accordance with protection being provided by the ceiling sprinkler system.
  2. A halocarbon and inert gas (clean agent) fire extinguishing system with extended discharge in accordance with Section 2.4.4.4.

### 2.3.3 Tape Cartridge Storage Rooms

2.3.3.1 Provide a separate room for tape cassette storage with minimum 1-hour fire-rated walls that span from slab to slab. Ensure any doors and windows to this room have a minimum 1-hour fire rating.

2.3.3.2 Provide automatic sprinkler protection in accordance with the recommendations for solid piled storage of unexpanded plastics in Data Sheet 8-9, *Storage of Class 1, 2, 3, 4 and Plastic Commodities*.

2.3.3.3 When limiting damage to an incipient fire is essential, provide an FM Approved clean agent fire extinguishing system with detection to protect the tape storage room. This detection supplements the automatic sprinkler protecting the facility. Install the halocarbon or inert gas (clean agent) fire extinguishing system in accordance with Section 2.4.4.4.

2.3.3.4 To further minimize the potential for a serious incident, do the following:

- A. Control access to the cassette storage room (e.g., lock doors).
- B. Back-up cassettes to an offsite location.

2.3.3.5 Provide fire hose connections for rooms containing movable aisle storage. Locate connections for fire hoses to reach all sections of the movable storage units.

### 2.3.4 Storage and Maintenance Areas

2.3.4.1 Protect storage areas in accordance with Data Sheet 8-9, *Storage of Class 1, 2, 3, 4 and Plastic Commodities*.

2.3.4.2 Locate new, packaged data processing equipment awaiting installation in storage and staging areas separate from data processing equipment rooms (i.e., where fire involving the storage will not expose critical equipment).

2.3.4.3 Do not store combustible materials in electrical or mechanical equipment rooms.

### 2.3.5 Utilities and Support Systems

#### 2.3.5.1 Power and Utility Cables

2.3.5.1.1 Protect grouped power and utility cables based upon their cable tray material and configuration in accordance with Section 2.2.7, Cables and Data Sheet 5-31, *Cable and Bus Bars*.

#### 2.3.5.2 Electrical Distribution System

2.3.5.2.1 Data centers rely on stable, uninterrupted electrical power. The performance goals for the electrical distribution system are as follows:

- A. The electrical distribution system must be designed with sufficient redundancy, so that the failure of a single piece of equipment will not result in the interruption of a large portion of the data processing capabilities of the data center.
- B. The power quality of the electrical distribution systems must meet the requirements of the utilization equipment.
- C. For critical data centers, sufficient emergency/standby power must be provided to allow operation of the data center without utility power.
- D. The design of the electrical distribution system must allow for the inspection, testing and maintenance of the major components. Special attention may be needed when designing uninterruptible power supplies, automatic transfer switches and emergency power systems to allow functional testing and maintenance of these devices without interrupting operations.
- E. Design the electrical distribution system to limit voltage dips at sensitive equipment due to faults in the electrical equipment. This design can be accomplished using current limiting fuses, fast acting trip devices, uninterruptible power supplies (UPS), continuous power supplies (CPS) or other means.
- F. Provide electrical protection in accordance with the applicable FM data sheets.

2.3.5.2.2 Electrical Power System Studies - For new construction or when major additions are made, perform the following studies in accordance with the International Testing Association's Standard for Acceptance Testing Specifications (NETA ATS) or another recognized equivalent standard:

- A. Short-circuit study
- B. Coordination study
- C. Arc-flash hazard analysis
- D. Load-flow study
- E. Stability study

#### 2.3.5.2.3 Electrical Utility

2.3.5.2.3.1 Provide a reliable source of power to the data center.

2.3.5.2.3.2 Have a qualified engineering firm perform a regional power supply reliability study as part of the site selection process for a new data center facility.

- A. Focus the study on the number, duration and cause of major system outages to the proposed site over a minimum 10-year period.
- B. Consider future load growth and the utility's plans to address the growth.

2.3.5.2.3.3 Provide a minimum of two independent utility feeds to the facility's main substation. (See Figure 2.3.5.2.3.3 for examples.) Arrange the utility feeds as follows:

- A. Supply each feed from a separate substation. Establish the power supply from substations that are as electrically independent as possible.
- B. Arrange the utility's protective scheme so that a fault in one substation or feed will not cause tripping of the other substations or feeds to the facility.
- C. Arrange each feed so that no single event, such as a substation fire, vehicle collision, wildland fire or excavation, will affect more than one feed.
- D. Where the utility feeds enter the main facility substation, provide a fire-resistive cable coating on all critical cables to ensure a single fire event does not affect more than one feed.
- E. Size the feeds so the facility can meet its entire power requirement with one feed out of service.
- F. Provide adequate lightning protection and surge protection for each feed in accordance with Data Sheet 5-11, *Lightning and Surge Protection for Electrical Systems*.

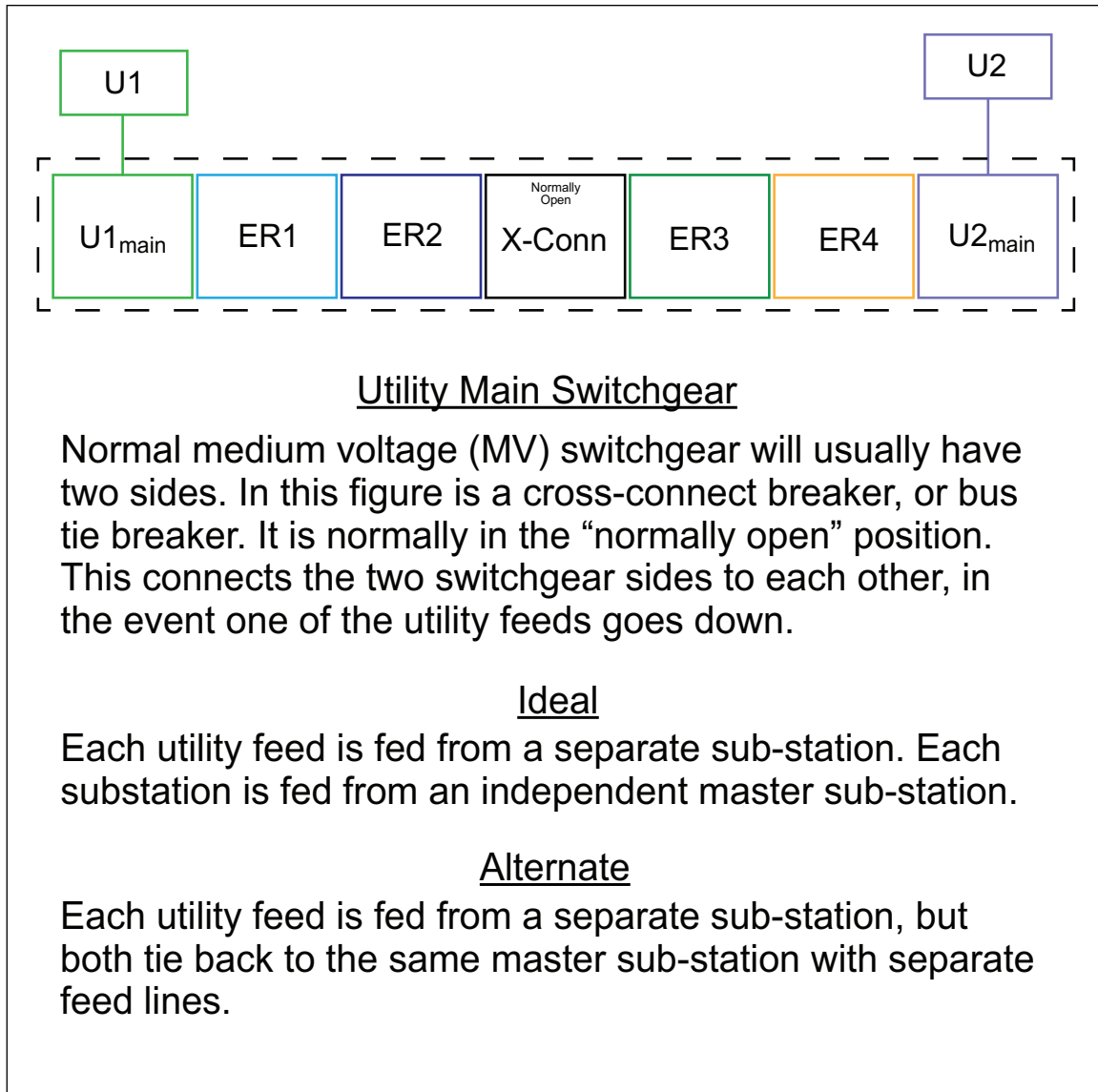

Fig. 2.3.5.2.3.3. Utility Main Switchgear

**2.3.5.2.4 Electrical Distribution System Operating at or Over 1,000 V**

2.3.5.2.4.1 Incorporate the following into the distribution system:

- A. Provide a minimum of N+1 transformers at the HV and MV level.
- B. Arrange the transformers to have adequate separation in accordance with Data Sheet 5-4, *Transformers*.
- C. Arrange the control/protection systems so they are not subject to a common impairment.
- D. Arrange the distribution system so the full demand of the site can be supplied with any one component of the system out of service for maintenance or repair. Ensure the design of the distribution system considers heating from harmonic distortion due to non-linear loads as required.
- E. Arrange feeders from the substation(s) to the equipment so an impairment in one run will not affect the other runs:
  - 1. Encase underground conduits in concrete, and place a tracer/warning tape above the conduits. Common splice vaults should not be used. If splices in the underground run are unavoidable, a separate splice vault should be used for each conduit.
  - 2. Feeders should not be run in a common underground tunnel unless provisions are in place to prevent a fire in the tunnel from affecting multiple feeders.
  - 3. Feeders run on overhead lines should be run on separate power poles and routed to prevent a common impairment from affecting multiple feeders.
- F. Provide lightning and surge protection for power supplies to data center systems in accordance with Data Sheet 5-11, *Lightning and Surge Protection for Electrical Systems*.

**2.3.5.2.5 Electrical Distribution System Operating Below 1,000 V**

2.3.5.2.5.1 Arrange the distribution system so the data center and support equipment can be supplied with a single distribution transformer, distribution cable, main breaker or tie breaker temporarily out of service.

2.3.5.2.5.2 Arrange the design of the distribution system to mitigate heating from harmonic distortion due to non-linear loads as required.

**2.3.5.2.6 Emergency/Standby Power Generators**

2.3.5.2.6.1 Provide sufficient on-site generation so that the data center operations will be unaffected by a loss of utility power. See Figure 2.3.5.2.6.1.

2.3.5.2.6.2 Locate diesel generators and fuel supplies in accordance with Data Sheet 5-23, *Design and Protection for Emergency and Standby Power Systems* and Data Sheet 13-26, *Internal Combustion Engines*.

2.3.5.2.6.3 Provide one of the following fuel supplies for the generators, listed in order of preference:

- A. A fuel supply which lasts 24 hours
- B. A documented service interruption plan (SIP) that specifies the generators are to be refueled at a rate that allows uninterrupted operation of the generators for 24 hours

2.3.5.2.6.4 Provide fire detection and protection in accordance with recommendations for fuel storage, fuel piping, and diesel generator protection in Data Sheet 5-23, *Design and Protection for Emergency and Standby Power Systems*.

2.3.5.2.6.5 To prevent accidental use, permanently cap old fuel lines to diesel fuel tanks if no longer connected.

2.3.5.2.6.6 When work is performed on fuel lines or fuel filters, use lock-out, tag-out procedures on fuel pumps supplying fuel to diesel generator day tanks to prevent accidental starting of pumps and discharge of fuel while the area is unattended.

2.3.5.2.6.7 Provide noncombustible soundproofing materials when soundproofing materials are required.

**2.3.5.2.7 Uninterruptible Power Supply (UPS)**



2.3.5.2.7.1 Where battery UPS systems are provided, design, locate and install the system in accordance with Data Sheet 5-28, *DC Battery Systems*.

2.3.5.2.7.2 Provide UPS power for data center systems susceptible to power fluctuations when the interruption of the system may result in significant business interruption or financial loss. See Data Sheet 5-23, *Design and Protection for Emergency and Standby Power Systems*.

#### **2.3.5.2.8 Battery Back-Up Units (BBU) for Distributed Power Systems**

2.3.5.2.8.1 When battery back-up units (BBU) (see Section 3.2.6) are used in the data processing equipment room, ensure they meet the following conditions:

- A. Limit the maximum power capacity to 20 kWh per server rack. See Section 3.2.6 for calculating power capacity.
- B. No more than two shelves containing BBU modules should be located together in the same area of the rack. (See Figure 2.3.2.7.1 for typical configuration.)

2.3.5.2.8.2 Server racks with Li-ion battery back-up units (BBU) exceeding the maximum capacity of 20 kWh per rack should be considered Energy Storage Systems (ESS), and the recommendations as identified in Data Sheet 5-33, *Energy Storage Systems*, should be followed.

#### **2.3.5.3 Heating, Ventilation, and Air Conditioning (HVAC)**

2.3.5.3.1 Provide heating, ventilation and air-conditioning (HVAC) systems in accordance with Data Sheet 1-45, *Air-Conditioning and Ventilation Systems*, Data Sheet 7-13, *Mechanical Refrigeration* and the recommendations in this section.

##### **A. Reliability**

Provide minimum N+1 online redundancy for HVAC components such as fans, air handling units (AHU), computer room air-handling (CRAH) units, computer room air-conditioning (CRAC) units, chillers, cooling towers, pumps, controls, humidification system components, etc. used to maintain the data processing equipment space environmental conditions (e.g., temperature, relative humidity) required for normal operations.

##### **B. Forced Air Distribution Systems**

1. Provide air-handling equipment and air flow paths (e.g., AHUs, ducts) that are independent from those connected to other building spaces.
2. If providing air-handling equipment and air flow paths that are independent from those connected to other building spaces is not physically possible, do the following:
  - a. Provide smoke dampers in ducts leading into the data processing equipment space; such that closure isolates the data processing equipment space from supply, return or exhaust airflow in the remainder of the building.
  - b. Provide listed smoke dampers with maximum leakage per Leakage Class II of UL 555S *Standard for Smoke Dampers*. Where smoke dampers are located at fire rated partitions, provide combination fire and smoke dampers rated per UL 555S **and** UL 555 *Standard for Fire Dampers*.
3. Provide a positive pressure of at least 0.05 in. (3 mm) water gauge in the data processing equipment rooms, relative to adjacent areas.
4. Interlock forced cooling air ventilation to reduce the ventilation air velocities to less than 5 ft/sec (1.5 m/s) upon activation of the pre-alarm condition for the VEVFD system.
  - a. Design forced air distribution systems using Computational Fluid Dynamics (CFD) modeling or equivalent design technologies to determine the ventilation air velocity and the need for an interlock to reduce the forced cooling air ventilation velocity upon smoke detection.

Measure maximum air velocities in the commissioning phase of the data center to confirm the ventilation air velocity.

- i. Horizontal velocity should be measured along the length of the aisle at heights of 5 ft (1.5 m) from floor, at the midpoint of the horizontal cable tray(s) height, and within 4-10 in. (0.1-0.25 m) of the ceiling.



- ii. Measure multiple locations along the length of the server rack aisle.
  - iii. Horizontal velocity should not be measured in close proximity to fan walls (as these velocities are expected to be higher) and should be measured no further than at the leading edge of the server racks from the fan wall.
- b. Conduct an acceptance test of the interlock(s) in accordance with Section 2.6.2.4 to confirm reduction of air velocities to less than 5 ft/sec (1.5 m/s) in the commissioning phase.
- i. Test interlocks regularly in accordance with Section 2.6.1.B.
  - ii. Keep documents on file for review during regular loss prevention visits.

#### C. Liquid Systems

1. Keep chilled water piping that is connected to air-handling and other cooling equipment controlling the data processing equipment space environment separate from chilled water piping serving the remainder of the building.
2. Do not route chilled water piping that provides cooling to building spaces other than the data processing equipment space through the data processing equipment space envelope.
3. Connect dedicated data processing equipment space piping as close as possible to the chilled water source and arrange in a loop with valves capable of dual feeding air handlers for critical applications in the event of a pipe failure.
4. Do not locate HVAC liquid piping, including chilled water, hot water, humidification and drains, above data processing equipment spaces.
5. Provide leak detection with alarm for water piping at air-handling units (AHU).

#### 2.3.5.3.2 Controlling HVAC Systems

##### 2.3.5.3.2.1 Provide controlling HVAC systems:

- A. Provide HVAC control systems (e.g., proportional-integral-derivative (PID) algorithm program with controls) to provide an alarm if the setpoint error and the historical rate of room temperature change indicate an impending overheating event.
- B. Provide alarms to initiate mitigation actions, based on several levels of temperature thresholds.
1. High temperature: No more than 2°F or 2°C above the normal setpoint operating temperature of the lower of either (a) the high data processing equipment temperature (as recommended by the OEM) measured at the equipment, or (b) the high space air temperature setpoint per the facility HVAC design.
  2. Rate of temperature change: As a result of the study recommended in the loss-of-cooling equipment contingency plan (see Section 2.7.7.1).
- C. Provide audible and visual alarms in the vicinity of the equipment and at a constantly attended location.
- D. Provide emergency power to HVAC systems (e.g., fans, CRAHs, chillers, cooling towers) for data processing equipment spaces.
- E. Provide battery or an alternative power backup such as capacitors for HVAC controls.

#### 2.3.5.3.3 Monitoring HVAC Equipment

##### 2.3.5.3.3.1 Provide monitoring HVAC equipment:

- A. Provide HVAC system equipment with sensors to detect equipment operation or failure. Automatically initiate alarms, remedial actions and start redundant (N+1) equipment. Measure the temperature or movement of the subject media directly (i.e., do not sense only electric motor failure). At a minimum, include the following:
1. Air handler supply duct airflow and temperature
  2. Chilled water flow and temperature
  3. Condenser water flow and temperature
  4. Thermal storage systems
  5. Evaporative cooling

6. Economizers
7. Refrigerant flow and temperature (especially for direct rack cooling)
8. Failure of electric power to this equipment

B. Initiate loss of electrical power or data processing equipment controls to activate alarms or actions to sense and mitigate data processing equipment space overheating. (See Section 2.7.3.)

C. Install sensors inside data processing equipment or equipment racks to detect abnormal equipment operation or overheating.

D. Provide temperature sensors for the data processing equipment space HVAC controls (e.g., wall mounted temperature sensors and thermostats) or for the building automation system software connected to those sensors.

E. Provide separate temperature sensors that are independent from the HVAC controls, if the HVAC sensors or controls are not configured for communication with alarms, electrical power controls or data processing equipment controls.

#### **2.3.5.3.4 HVAC System Commissioning**

2.3.5.3.4.1 Do not operate data processing equipment during or following the installation of new HVAC equipment or controls, or the modification of existing HVAC equipment or controls, without fully commissioning the systems to demonstrate proper operability across the full range of functions. This commissioning includes testing automatic interlocks and controls associated with abnormal conditions or system malfunctions. Include data processing equipment high-temperature alarms and actions, and data processing equipment room high-temperature and excessive rate of temperature rise alarms and actions.

#### **2.3.5.3.5 Filters**

2.3.5.3.5.1 Provide heating, ventilation and air-conditioning (HVAC) filters that are listed to Underwriters Laboratories (UL) Standard 900 for fire performance.

#### **2.3.5.3.6 Smoke Management Systems**

2.3.5.3.6.1 If a smoke management system is to be installed, retain a competent and experienced firm to design the system in accordance with site-specific performance goals.

2.3.5.3.6.2 When installed, design smoke management systems to include the smoke control and removal recommendations identified in Data Sheet 1-45, *Air Conditioning and Ventilating Systems*.

#### **2.3.5.4 Power Isolation of Data Processing Equipment and HVAC Systems**

The goals of the recommendations for power isolation of data processing equipment and HVAC systems are to remove the potential for reignition and minimize the circulation of smoke to sensitive electronic equipment. These goals are further explained in Section 3.2.8.5.

Although the installation of a power disconnect system to rapidly isolate power and HVAC supplies can seem contrary to the critical power/business continuity requirement of most data centers, an electrical fault is the most probable fire ignition source in a data center. To ensure adequate control of fire propagation, prevent reignition and allow emergency response personnel access, having a way to reliably isolate power is necessary.

Although a relatively high level of electrical fault protection exists throughout a data center via circuit breakers, fuses or other means, these cannot be relied upon to de-energize the faulty equipment and remove the ignition source. Some of the scenarios where electrical protection could fail to clear an electrical fault and remove the ignition source are included in Section 3.2.8.2.2.

#### **2.3.5.4.1 Power Isolation Method**

2.3.5.4.1.1 Provide a power isolation method to achieve the following (separately or together):

- A. De-energize all electrical power to the data processing equipment in the room or designated zone(s), except power to lighting, in the event of sprinkler, water mist system, clean agent fire extinguishing system and/or hybrid fire extinguishing system operation.

B. When appropriate, de-energize all dedicated heating, ventilation and air-conditioning (HVAC) systems for the data processing equipment serving the room or designated zone(s) in the event of sprinkler, water mist system, clean agent fire extinguishing system and/or hybrid fire extinguishing system operation. See Section 2.3.5.3 for further guidance on the impact of power isolation to HVAC equipment.

C. If abrupt power isolation will damage the data processing equipment, use a controlled shutdown of the data processing equipment prior to isolation of the power source.

2.3.5.4.1.2 Provide the appropriate power isolation method based on the type of fire protection installed and site conditions, per the criteria below. The critical goal is to achieve power isolation before the end of the fire protection agent duration.

A. For areas protected by a wet or preaction sprinkler system in accordance with the recommendations of Section 2.4.4.2, or a water mist system in accordance with the recommendations of Section 2.4.4.3, provide one of the following, listed in order of preference:

1. Automatic power isolation with controlled depowering
2. Manual power isolation in accordance with Section 2.7.3

B. For areas protected by only a halocarbon or inert gas (clean agent) or hybrid (water and inert gas) fire extinguishing system, provide one of the following, listed in order of preference:

1. Automatic power isolation with a controlled time-delay (see Section 3.2.8.5)
2. Manual power isolation in accordance with Section 2.7.3 if all the conditions for manual power isolation listed in Section 2.3.5.4.1.3 are met.

2.3.5.4.1.3 If the need for business continuity of the data processing equipment prevents the use of automatic power isolation, a manual power isolation method and plan as recommended in Section 2.7.3 is acceptable for areas protected by only a clean agent fire extinguishing system if that system can be relied on in all situations and has been evaluated as equivalent to automatic power isolation. All of the following conditions must exist in order to accept manual power isolation:

A. A VEWFD system is provided in all equipment rooms, according to the recommendations of Section 2.4.3.

B. VEWFD alarms are monitored at a constantly attended location, and alarms are immediately communicated to emergency responders. In addition, alarms may also be communicated to emergency responders via notifications to their mobile device.

C. Qualified and highly trained emergency responders are on site 24 hours per day and have knowledge of all power sources and the methods of isolating power to data center equipment, beginning as localized as conditions permit. Responders should be authorized to execute the emergency power isolation plan as needed. Response should occur prior to the activation of fire protection systems.

D. The data processing equipment room ceiling/roof, floor and walls (not including hot/cold aisle partitions) are of noncombustible construction in accordance with Sections 2.2.2, 2.2.3, 2.2.5 and 2.5.6.

E. Excellent human element programs are established and implemented:

1. Fire protection system impairments are well managed.
2. Ignition sources are controlled.
3. Maintenance, testing and inspection of fire protection and detection systems are regularly completed.
4. Penetrations to data processing equipment rooms are properly maintained.
5. Electrical maintenance, testing and inspection are regularly completed.
6. Housekeeping is excellent.
7. An emergency response plan is in place that includes data processing equipment overheating, smoke detection and manual fire extinguishing equipment operation response.

F. The power isolation plan is:

1. Agreed upon by senior site management,
2. Reviewed at least quarterly,
3. Tested or drilled at least annually by all individuals involved in the plan.
4. Agreed upon and communicated to the fire service.

G. The time to complete the manual power isolation should be measured in each annual test/drill. It should be within a maximum of 10 minutes after the fire detection alarm is received and should take into account any power-isolation authorization request procedure that might exist at the facility. The test/drill should confirm that the plan is in accordance with Section 2.7.3.3.

Reference Data Sheet 4-9, *Halocarbon and Inert Gas (Clean Agent) Fire Extinguishing Systems on Acceptance of Installations*, to determine duration of protection.

## 2.4 Protection

This section provides recommendations on specifications for the design of detection and fire protection for the various equipment and occupancy areas in the data center.

Recommendations on the typical areas of a data center and the general protection recommendations that apply to these areas are included in Section 2.3. It includes attributes that can impact the effectiveness of fire protection and identifies specifications (e.g., air flow, cable type) that provide that protection option.

### 2.4.1 General

The goals for effective fire protection of data processing equipment and HVAC systems are to remove the potential for reignition and minimize the circulation of smoke to sensitive electronic equipment.

2.4.1.1 Establish a formal manual power isolation plan in accordance with Section 2.3.5.4 and Section 2.7.3 for all locations regardless of the type of fire protection being provided.

2.4.1.2 Do not use aerosol generator fire extinguishing system units for the protection of the data center, related areas or electronic equipment.

### 2.4.2 Portable Fire Extinguishers

2.4.2.1 For energized electrical hazards, provide carbon dioxide or clean agent portable fire extinguishers listed to protect electronic equipment in accordance with Data Sheet 4-5, *Portable Extinguishers*. (See Section 3.3.1.1)

A. Use a maximum floor area of 3,000 ft<sup>2</sup> (280 m<sup>2</sup>) for each portable fire extinguisher.

B. Use a maximum travel distance of 75 ft (23 m) between each portable fire extinguisher.

2.4.2.2 For ordinary combustibles and energized electrical fires, provide portable fire extinguishers of the type or combination of types that are suitable per with Data Sheet 4-5, *Portable Fire Extinguishers*, when both hazards are present.

A. Use a minimum rating of 2-A (NFPA 10 rating and classification).

B. Use a maximum floor area of 3,000 ft<sup>2</sup> (280 m<sup>2</sup>) per portable fire extinguisher with a 2-A rating, and 1,500 ft<sup>2</sup> (140 m<sup>2</sup>) per each additional "A" rating to a maximum of 11,250 ft<sup>2</sup> (1045 m<sup>2</sup>).

C. Use a maximum travel distance of 75 ft (23 m) between each portable fire extinguisher.

2.4.2.3 Do not use dry chemical fire extinguishers in data processing equipment rooms with data processing equipment or electronic equipment.

2.4.2.4 Locate a portable fire extinguisher at each entrance of the data processing equipment room. Locate additional fire extinguishers in the data processing equipment room based upon the above recommendations for area per extinguisher and travel distance.

2.4.2.5 Locate a sign adjacent to (or verify the adequacy of the labeling on) the portable fire extinguisher to identify the type of fire it is intended to extinguish.

2.4.2.6 Provide training to staff working in the area on the selection and safe use of portable fire extinguishers.

### 2.4.3 Detection: Design Specifications

2.4.3.1 Install fire detection per Data Sheet 5-48, *Automatic Fire Detection*, in conjunction with the following recommendations.

2.4.3.2 Use one of the following FM Approved VEWFD systems, appropriate for the characteristics of the occupancy:

## A. Air aspirating

## B. Intelligent high-sensitivity spot detection; photoelectric type

2.4.3.2.1 Limit cooling air velocities in data processing equipment rooms and any utility rooms upon activation of the pre-alarm for the FM Approved Very Early Warning Fire Detection (VEWFD) system to a maximum of 5 ft/sec (1.5 m/s) in accordance with Section 2.3.5.3.1.B.4 to provide adequate fire detection (reference Section 2.4.3) and protection (reference Section 2.4.4.1).

2.4.3.3 Do not install automatically operated smoke exhaust systems in the data processing equipment rooms.

2.4.3.3.1 Where automatic operation is required by local code, interlock the activation of the smoke exhaust system with the alarm for operation of the sprinkler system. Do not interlock activation of the smoke exhaust system with the fire detection system.

2.4.3.4 Transmit fire alarms to a central supervisory station or other constantly attended location.

2.4.3.5 Transmit local alarms (e.g., alert, pre-alarm and alarm condition) from the protected area to a constantly attended location.

2.4.3.6 Install the fire alarm control panel for fire detection in accordance with Data Sheet 5-40, *Fire Alarm Systems*.

**2.4.3.7 Air Aspirating Detection**

2.4.3.7.1 Install sensors or ports to monitor the return air. (See Figure 2.4.3.7.1.)

A. Locate sensors or ports at the return air inlet of each HVAC unit and/or at the interface of the exhaust air plenum (see Section 3.3.2).

B. Locate sensors or ports so each covers an area no greater than 4 ft<sup>2</sup> (0.4 m<sup>2</sup>) of the return opening.

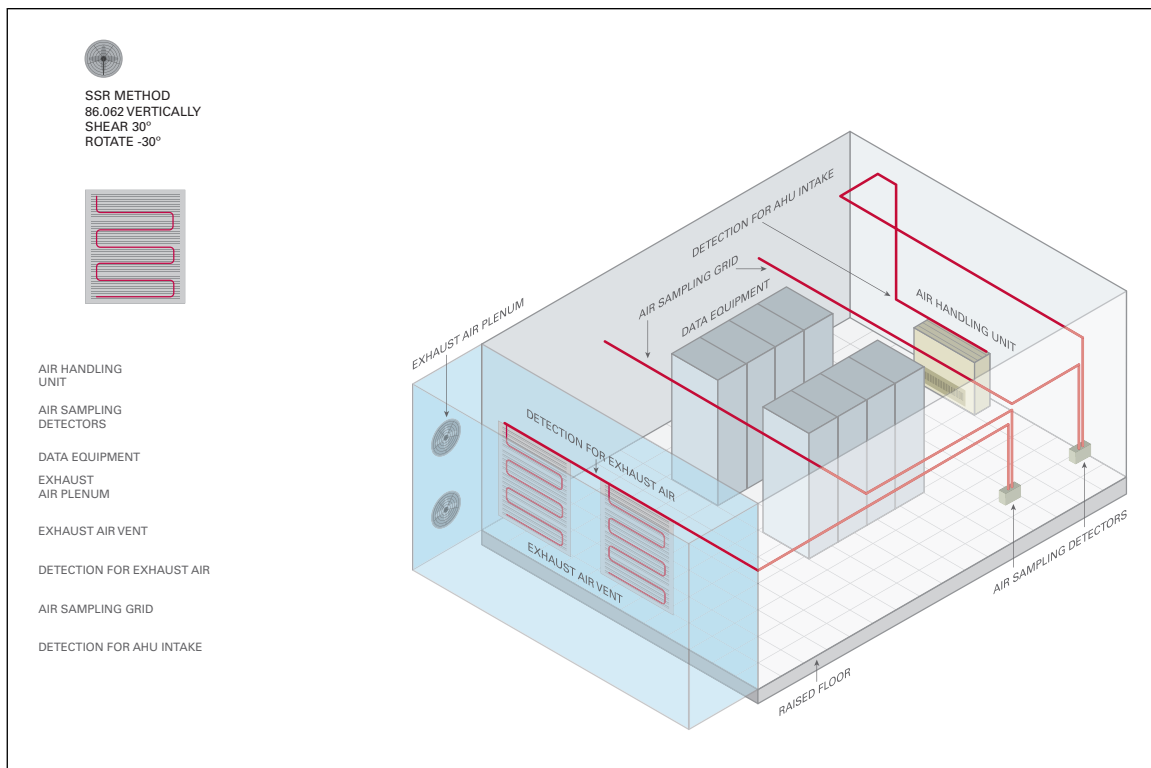

Fig. 2.4.3.7.1. Very early warning fire detection (VEWFD); air-aspirating type

2.4.3.7.2 Where a single level of detection is used, install a sensor or port in an area no larger than 200 ft<sup>2</sup> (18.6 m<sup>2</sup>). (See Figure 2.4.3.7.1)

- A. The sensors or ports do not need to be located in the center of the bay.
- B. Do not locate sensors or ports within 3 ft (0.9 m) of HVAC supply outlets unless detecting for failure originating with the HVAC unit (e.g., burning belt, bearing).

2.4.3.7.3 If two levels of detection are used, install a sensor or port in an area no larger than 400 ft<sup>2</sup> (37.2 m<sup>2</sup>) for both levels.

2.4.3.7.4 Provide two levels of detection where cable trays impede the flow of smoke to the ceiling.

- A. Locate one level of detection below the cable trays and one level at the ceiling.
- B. Stagger the sensors or ports in an area no larger than 200 ft<sup>2</sup> (18.6 m<sup>2</sup>) between each level.

2.4.3.7.5 For air-sampling VEWFD, do not exceed a transport time of 60 seconds from the most remote port to the detection unit.

#### **2.4.3.8 Intelligent High-Sensitivity Spot Smoke Detection**

2.4.3.8.1 Use FM Approved intelligent high-sensitivity spot smoke detectors of the photoelectric type when cooling air velocities do not exceed either 5 ft/s (1.5 m/s) or 60 air changes per hour.

2.4.3.8.2 Install FM Approved intelligent high-sensitivity spot smoke detectors to monitor the return air.

A. Locate the spot detectors at the return air inlet of each HVAC unit and/or at the interface of the exhaust air plenum (see Section 3.2.4).

B. Locate the spot detectors so each covers an area no greater than 4 ft<sup>2</sup> (0.4 m<sup>2</sup>) of the return opening.

2.4.3.8.3 Provide at least two FM Approved intelligent high-sensitivity spot smoke detectors in each protected space or zone for initiation of the protection system.

2.4.3.8.4 If an intelligent VEWFD spot-type smoke detector is used below a raised floor, ensure it is properly orientated as indicated in its FM Approval listing.

2.4.3.8.5 Install the FM Approved intelligent high-sensitivity spot smoke detectors in accordance with the manufacturer's specification for spacing based on the air movement (e.g., air changes per minute/hour in the protected space or zone).

2.4.3.9 Provide minimum sensitivity settings above the ambient airborne levels and consider the impact of functional devices on the HVAC system (e.g., outside air economizers with or without dampers) for alert, pre-alarm and alarm conditions.

2.4.3.9.1 Where high air velocities (exceeding either 5 ft/s (1.5 m/s) or 60 air changes per hour) are required for proper cooling, provide an interlock to reduce the air flow velocity upon fire detection in accordance with Section 2.3.5.3.1B.

2.4.3.10 Provide an annunciator panel at the fire alarm control panel arranged to indicate pre-alarm and alarm signals from VEWFD system.

2.4.3.11 Conduct smoke tests (see Appendix C) when the VEWFD system is installed to verify smoke detectors are properly located with regard to air flow and velocity within the protected area, including ventilation and stratification within the protected area.

#### **2.4.3.12 Portable Detection**

2.4.3.12.1 Supplement fixed smoke detection with portable handheld detection devices (e.g., aerosol monitors and thermal imaging devices) to assist in locating the origin of an alarm within a detection zone.

### **2.4.4 Suppression: Design Specifications**

#### **2.4.4.1 General**

The reliability of a protection system is a function of the complexity of the system and the number of interacting components for its operation.

An automatic sprinkler system or water mist system may be used to protect a data processing equipment room with a forced air ventilation cooling system with a maximum nominal upward velocity through perforated floor openings, and a horizontal airflow of maximum 5 ft/sec (1.5 m/sec).

2.4.4.1.1 Where higher air velocities are required for proper cooling, provide an interlock to reduce the air flow velocity upon fire detection in accordance with Section 2.3.5.3.1B.

**2.4.4.2 Automatic Sprinklers**

2.4.4.2.1 Install sprinkler systems in accordance with Data Sheet 2-0, *Installation Guidelines for Automatic Sprinklers*, the equipment manufacturer’s manual and the recommendations in this section of Data Sheet 5-32.

2.4.4.2.2 Provide one of the following types of automatic sprinkler protection, listed in order of preference based on reliability and maintenance (i.e., annual trip test; refer to Section 3.3.3.1):

- A. Wet system
- B. Non-interlocked preaction system
- C. Single-interlocked preaction system
- D. Double-interlocked system

The type of automatic sprinkler system (reference Table 2.4.4.2.2) provided should consider the impact of a delay in water being applied to the fire and ability to conduct maintenance. In particular, the extended delay from a double-interlock preaction system requires both smoke detection and sprinkler activation which can negatively impact control of the fire and the available water supply. In addition, the complexity of the preaction valve trim decreases the availability of the fire protection system.

Table 2.4.4.2.2. Sprinkler System Operation Sequence

<i>Sprinkler System Type</i>	<i>Detection Activation</i>	<i>Function<sup>(Note 1)</sup></i>	<i>Sprinkler Activation</i>	<i>Supervision<sup>(Note 2)</sup></i>
Wet	Not Applicable	N/A	Water discharges	Not Applicable
Non-interlocked preaction	Water fills piping	Or	Water fills piping and discharges	Yes
Single-interlocked preaction	Water fills piping	N/A	w/detection, water discharges	Yes
			w/o detection, no water in piping	
Double-interlocked preaction	Water does not fill piping; preaction control unit monitors sprinkler supervisory pressure	And	Sprinkler piping fills with water only if detection and sprinkler is activated	Yes

Note 1. Action needed for sprinkler piping to fill with water.

Note 2. The sprinkler system piping is pressurized with air or nitrogen or maintains a vacuum to supervise the integrity of the sprinkler piping network. If the system piping or a sprinkler is damaged, the supervisory pressure is reduced and a low air supervisory alarm is activated. Supervision is also one portion of the releasing operation for double interlocked preaction systems.

2.4.4.2.3 Preaction systems. When using a preaction type automatic sprinkler system for a non-interlock, single-interlock, or double-interlock system throughout the data center, provide it in accordance with the following recommendations:

- A. Install in accordance with the applicable recommendations for a preaction sprinkler system in Data Sheet 2-0, *Installation Guidelines for Automatic Sprinklers* and in addition to the following:
  1. When using a non-interlock or single-interlock preaction sprinkler system arrangement, base the sprinkler demand on a wet system.
  2. In a double-interlock configuration, design the sprinkler system based on a dry system.
  3. Provide a maximum water delivery delay of 30 seconds to the most remote sprinkler.



4. Provide a sectional valve above the preaction valve in accordance with Item D to allow proper inspection, testing, and maintenance to be conducted in accordance with Data Sheet 2-81, *Fire Protection System Inspection, Testing and Maintenance*.
- B. Activate the preaction valve with smoke detectors and control panel in accordance with Data Sheet 5-48, *Automatic Fire Detection*, in addition to the following:
1. Provide one of the following VEWFD detection methods in accordance with Section 2.4.3:
    - a. Air-aspirating smoke detection
    - b. Intelligent high-sensitivity spot detection
  2. If both a preaction sprinkler system and halocarbon or inert gas (clean agent) fire extinguishing system are installed, provide two independent VEWFD smoke detection systems. Provide the fire alarm threshold for the halocarbon or inert gas (clean agent) fire extinguishing system lower than that for the preaction automatic sprinkler system.
  3. In a double-interlock preaction system, do not cross-zone detection for activation of the pre-action system valve. Use the initiating signal of only one detector or detection system zone in the protected area with detection at the air return. In data halls with containment panels reaching up to the ceiling level a cross-zoned detection adds another interlock level due to isolation of the smoke. This configuration will lead to a "triple" interlock situation if applied to FM Approved double interlock preaction systems.
  4. Annunciate an alert, pre-alarm and alarm condition in a constantly attended location when the VEWFD detection has activated.
  5. Provide a local visual and/or audible alarm within the protected area when an alarm condition is activated.
  6. Provide an alarm signal to the building fire alarm control panel area when an alarm condition is activated.
  7. Arrange the control valve for all preaction types of sprinkler systems to actuate upon:
    - a. the pre-alarm level or earlier for air-aspirating detection.
    - b. the pre-alarm for intelligent high-sensitivity spot detection.
- C. Install an alarm valve for the sprinkler systems protecting the data center equipment room separate from other sprinkler systems.
- D. For a sprinkler system with a preaction valve, provide a 2 in. (50 mm) diameter test discharge line located above (downstream from) the preaction sprinkler valve assembly (see Figure 2.4.4.2.3.D) for trip testing of the preaction valve.
1. Install a normally closed indicating valve with supervision on the test discharge line.
  2. Install a normally open indicating valve with supervision on the system riser above (downstream from) the intake for the test discharge line.
- E. Install the fire alarm control panel for the preaction sprinkler in accordance with the applicable recommendations in Data Sheet 5-40, *Fire Alarm Systems*.



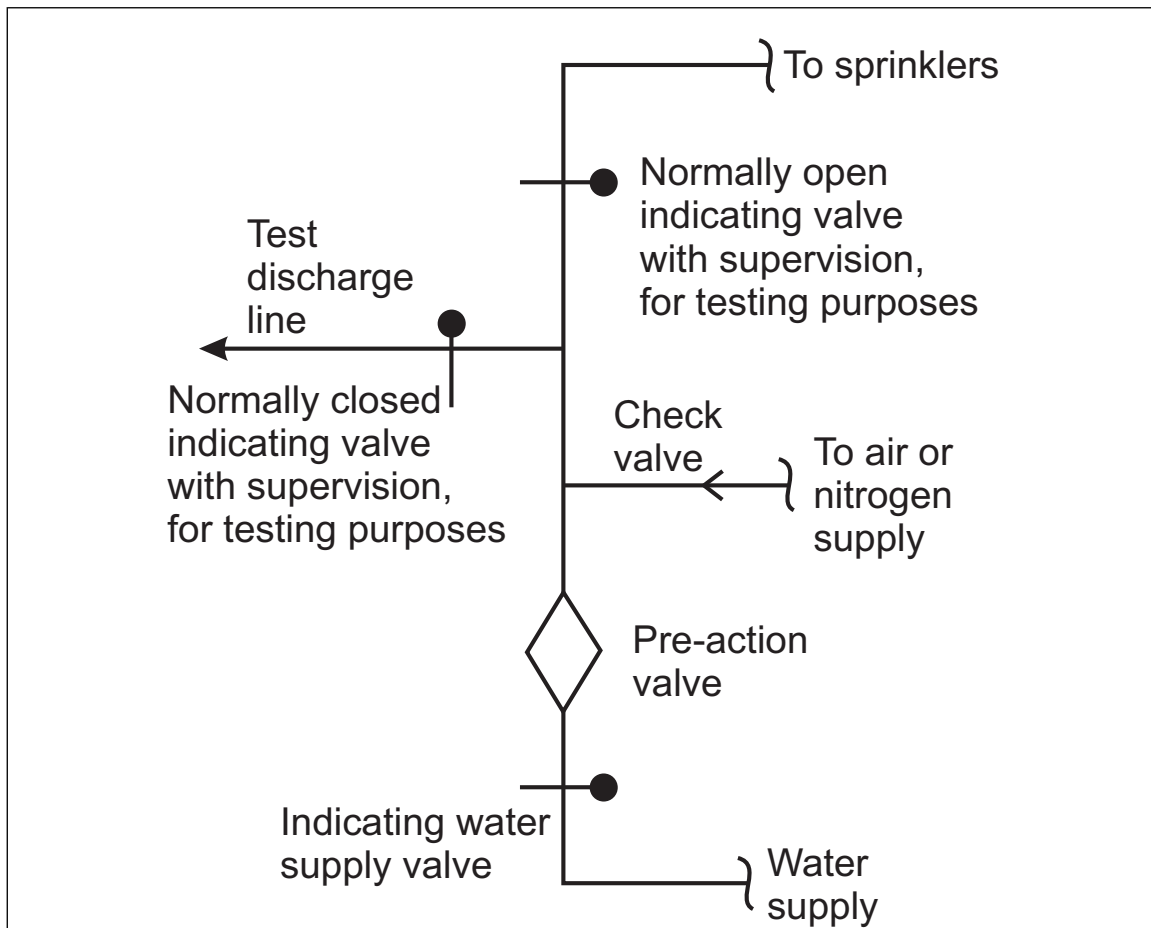

Fig. 2.4.4.2.3.D. Schematic of preaction valve with test discharge line

#### 2.4.4.2.4 Data Processing Equipment Rooms

Design the protection for hot/cold aisle containment systems in accordance with Section 2.3.2.4.

Design the protection for Li-ion battery back-up units in accordance with Section 2.3.2.7. The protection recommendations included in this section are based upon Li-ion batteries not being present in the data processing equipment room as distributed battery back-up units in server racks or a UPS.

2.4.4.2.4.1 Design the FM Approved automatic quick-response (QR) sprinkler protection with the following parameters:

- A. Application density of 0.2 gpm/ft<sup>2</sup> (8 mm/min) over 2500 ft<sup>2</sup> (230 m<sup>2</sup>) for wet pipe systems and 3500 ft<sup>2</sup> (330 m<sup>2</sup>) for dry pipe systems as designated by the sprinkler configuration in Section 2.4.4.2.2.
- B. Maximum 30 ft (9 m) ceiling. (Refer to Section 3.3.3.1.)
- C. Sprinkler deflector distance from ceiling:
  - 1. Minimum: 1.75 in. (44 mm)
  - 2. Maximum: 4 in. (100 mm)
- D. Maximum spacing of 12 ft (3.6 m)
- E. Provide linear and area spacing of sprinklers for the designated hazard category in accordance with the recommendations in Data Sheet 2-0, *Installation Guidelines for Automatic Sprinklers*, up to a 30 ft (9 m) ceiling.

F. Provide a minimum 3 ft (0.9 m) clearance from the sprinkler to the cable tray. For a sprinkler with a cable tray clearance of less than 3 ft (0.9 m), use the obstruction guidelines specific to discharge pattern of ceiling-level pendent and upright nonstorage sprinklers in Data Sheet 2-0. The position of the cable tray relative to the ceiling sprinkler is so the entire width of the cable tray in its least dimension is located outside of the checkerboard pattern shown in the figure for the applicable Nonstorage sprinkler type (i.e., standard-coverage or extended-coverage). This will allow for ceiling sprinkler discharge to protect the cables within the cable tray. Install supplemental sprinklers below any cable tray that is wider than 4 ft (1.2 m).

G. When elevated cable trays are present, provide a minimum pressure of 12 psi (0.8 bar) at the sprinkler or a maximum horizontal offset distance of 4 ft (1.2 m) from the sprinkler to the cable trays above the servers.

H. Hose stream allowance of 250 gpm (950 L/min)

I. Water supply duration of 60 minutes, including the hose stream allowance.

#### 2.4.4.2.5 Below Raised Floors and/or Above-Ceiling Spaces (Concealed Spaces)

A. Design the automatic extended coverage (EC) non-storage sprinkler protection to deliver an application density of 0.2 gpm/ft<sup>2</sup> (8 mm/min.) over 2500 ft<sup>2</sup> (230 m<sup>2</sup>) for wet pipe systems and 3500 ft<sup>2</sup> (330 m<sup>2</sup>) for dry pipe systems as designated by the sprinkler configuration in Section 2.4.4.2.2.

B. When designed as a wet pipe system, use automatic EC nonstorage sprinklers with a temperature rating of 165°F (74°C).

C. When designed as a dry pipe system, use automatic EC nonstorage sprinklers with a temperature rating of 280°F (140°C).

D. Reduce the linear spacing of extended coverage (EC) nonstorage sprinklers in accordance with Obstructions to Discharge Pattern of Pendent and Upright Nonstorage Sprinklers in Data Sheet 2-0, *Installation Guidelines for Automatic Sprinklers*, to account for the specific deflector to floor distance and provide an unobstructed discharge pattern for protection of cables in an open cable tray.

#### 2.4.4.3 Water Mist Systems

2.4.4.3.1 An automatic water mist system FM Approved for "Protection of Data Processing Equipment Rooms/Halls" or "HC-2 Occupancies" may be used to protect a data processing equipment room with a forced air distribution system having a maximum nominal upward velocity of 3.3 ft/sec (1 m/s) through perforated floor openings and a maximum 4 ft/sec (1.2 m/s) horizontal airflow (or forced air flow that meets the provisions of the system's FM Approval listing). (See Figures 2.3.2.2.3 and 2.3.2.3.5.)

2.4.4.3.2 Install water mist systems in accordance with all applicable recommendations in Data Sheet 4-2, *Water Mist Systems*, and the manufacturer's design, installation, operation, and maintenance manual shown in the FM Approval listing for the specific application and the recommendations in this section of Data Sheet 5-32.

2.4.4.3.3 Provide one of the following types of automatic water mist systems (listed in order of preference based on reliability and maintenance; refer to Section 3.3.3.1):

- A. Wet system
- B. Non-interlocked preaction system
- C. Single-interlocked preaction system
- D. Double-interlocked preaction system

The type of automatic water mist system (reference Table 2.4.4.1.2 for sprinklers) provided should consider the impact of a delay in water being applied to the fire and ability to conduct maintenance. In particular, the extended delay from a double-interlock preaction system requires both smoke detection and water mist nozzle activation which can negatively impact control of the fire and the available water supply. In addition, the complexity of the preaction valve trim decreases the availability of the fire protection system.

2.4.4.3.4 Provide a water supply for a 60-minute duration.

2.4.4.3.5 Preaction systems. When using a preaction type automatic water mist system as either a non-interlock, single-interlock or double interlock system throughout the data processing equipment room, provide it in accordance with the following recommendations:

A. Install the system in accordance with the applicable recommendations for a preaction water mist system in Data Sheet 4-2, *Water Mist Systems*.

1. Provide the nozzle water demand area in accordance with the FM Approval listing and the manufacturer's FM Approved Design, Installation, Operation and Maintenance manual.
2. Provide a maximum water deliver delay of 30 seconds to the most remote automatic nozzle.
3. Provide a sectional valve above the preaction valve in accordance with Item D to allow proper inspection, testing, and maintenance to be conducted in accordance with Data Sheet 2-81, *Fire Protection System Inspection, Testing and Maintenance*.

B. Activate the preaction valve with VEWFD smoke detectors and control panel in accordance with Data Sheet 5-48, *Automatic Fire Detection*, in addition to the following:

1. Provide one of the following VEWFD detection methods in accordance with Section 2.4.3:
  - a. Air-aspirating smoke detection
  - b. Intelligent high-sensitivity spot detection.
2. Provide two independent VEWFD smoke detection systems if both a preaction automatic water mist system and halocarbon or inert gas (clean agent) fire extinguishing system are installed, with the fire alarm threshold for the clean agent system lower than that for the preaction automatic water mist system.
3. In a double-interlock preaction system, do not cross-zone detection for activation of the pre-action system valve. Use the initiating signal of only one detector or detection system zone in the protected area with detection at the air return.

In data halls with containment panels reaching up to the ceiling level a cross-zoned detection adds another interlock level due to isolation of the smoke. This configuration will lead to a "triple" interlock situation if applied to FM Approved double interlock preaction systems.

4. Annunciate an alert, pre-alarm and alarm condition in a constantly attended location when the pre-alarm and/or alert setting for the VEWFD detection has activated.
5. Provide a local visual and/or audible alarm within the protected area when an alarm condition is activated.
6. Provide an alarm signal to the building fire alarm control panel area when an alarm condition is activated.
7. Arrange the control valve for all preaction types of automatic water mist systems to actuate upon:
  - a. the pre-alarm level or earlier for air-aspirating detection.
  - b. the pre-alarm for intelligent high-sensitivity spot detection.

C. Install an alarm check valve for the water mist systems protecting the data processing equipment room separate from other water mist systems.

D. For a water mist system with a preaction valve, provide a test discharge line located above (downstream from) the preaction alarm check valve assembly (see Figure 2.4.4.2.3.D) for trip testing of the preaction valve.

1. Install a normally closed indicating valve with supervision on the test discharge line.
2. Install a normally open indicating valve with supervision on the system riser above (downstream from) the intake for the test discharge line.

E. Install the fire alarm control panel for the preaction water mist system in accordance with the applicable recommendations in Data Sheet 5-40, *Fire Alarm Systems*.

2.4.4.3.6 Where overhead, multi-tiered, open cable trays of propagating cables are present in the data processing equipment room, provide an FM Approved automatic water mist system specifically listed for "HC-2 Occupancies".

2.4.4.3.7 For high-pressure water mist systems, use the supply pump specified in the FM Approval listing.

2.4.4.3.8 Locate nozzles with respect to continuous and discontinuous obstructions in accordance with the design, installation operation and maintenance manual specified in the FM Approval listing.

2.4.4.3.9 When a low-pressure water mist system is supplied by the building sprinkler system, install a separate water flow switch for the water mist system.

2.4.4.3.10 When protection of the area below the raised floor is provided by a water mist system, provide an FM Approved automatic water mist system specifically listed for "Protection of Data Processing Equipment Rooms/Halls - Below-Floor Protection".

2.4.4.3.10.1 Use water mist systems protecting the area below a raised floor for the maximum number of tiered open cable trays of propagating cables designated in the FM Approval listing.

#### **2.4.4.4 Halocarbon and Inert Gas (Clean Agent) or Hybrid (Water and Inert Gas) Fire Extinguishing Systems: Design Specifications**

2.4.4.4.1 An FM Approved halocarbon or inert gas (clean agent) or hybrid fire extinguishing system can provide adequate protection, if all of the following conditions are met:

- A. A controlled, automatic power-down is provided for the room and equipment (except for emergency lighting) upon smoke detection by VEWFD in accordance with Section 2.3.5.4.
- B. Construction of the equipment room is noncombustible.
- C. Equipment enclosures/racks are constructed of noncombustible materials.
- D. Hot/cold aisle containment and hot collar systems are constructed in accordance with Section 2.3.2.4.
- E. Shutdown and/or damper of ventilation systems that use return or make-up air is provided.

2.4.4.4.2 Construct the physical building envelop in accordance with Section 2.2 to maintain the design concentration of clean extinguishing agent or hybrid media for whichever is the longer duration: 10 minutes, or until the affected equipment or components can be de-energized.

2.4.4.4.3 Provide the FM Approved halocarbon or inert gas (clean agent) fire extinguishing system or hybrid (water and inert gas) fire extinguishing system in accordance with design and installation recommendations in Data Sheet 4-9, *Halocarbon and Inert Gas (Clean Agent) Fire Extinguishing Systems*, or Data Sheet 4-6, *Hybrid (Water and Inert Gas) Extinguishing System*, respectively, and the manufacturer's design, installation and operation manual included in the FM Approval listing.

2.4.4.4.4 Actuate halocarbon or inert gas (clean agent) fire extinguishing systems or hybrid (water and inert gas) fire extinguishing systems with automatic FM Approved VEWFD detection, manual operation station and emergency mechanical manual operation at the clean agent storage cylinders.

2.4.4.4.5 When an FM Approved clean agent (halocarbon or inert gas) or hybrid (water and inert gas) fire extinguishing system is used to protect equipment hazards in the data processing equipment room in accordance with Section 2.3.2.2 and 2.3.2.3, provide:

- A. Simultaneous halocarbon extinguishing system protection in both the data processing equipment room and below the raised floor. Use the same halocarbon extinguishing agent for both areas. (See Section 3.3.3.3.1.) Or
- B. Inert gas or hybrid (water and inert gas) extinguishing system protection in either:
  - 1. The data processing equipment room and below the raised floor, or
  - 2. Only below the raised floor

2.4.4.4.6 For the protection of data processing equipment (e.g., servers, electrical equipment, batteries, and cables; refer to Section 2.3.5), do the following:

- A. When the electrical equipment and/or cables are de-energized, provide the design concentration for an ordinary combustibile (Class A) fire in accordance with the system's FM Approval listing.
- B. When the electrical equipment and/or cables are not immediately de-energized but have a time delay power disconnect, provide the design concentration for an energized electrical fire (Class C) identified for the specific extinguishing agent in Appendix D.

2.4.4.4.7 Provide the proper clearance of the discharge nozzle(s) from the sidewall(s) of a hot/cold aisle containment system or other obstructions (e.g., cable trays) in accordance with the manufacturer's design, installation, and operation manual included in the FM Approval listing (see Section 2.3.2.4).

2.4.4.4.8 When magnetic hard disk drives (HDD) and storage systems are susceptible to disruption of performance by an excessive sound pressure level from the discharge of a clean agent fire extinguishing system, do the following:

A. For FM Approved inert gas fire extinguishing systems use a regulated pressure system to control flow and pressure from the discharge valve.

B. Use an FM Approved halocarbon or inert gas (clean agent) fire extinguishing system that has a noise reducing discharge nozzle listed as a component of the fire extinguishing system. Install the discharge nozzles as follows:

1. Determine the minimum radial distance based upon using the noise level or sound pressure level that can produce damage to the hard disk drive in conjunction with the sound pressure level of the discharge nozzle in the FM Approval listing.
2. Provide the discharge nozzle at a minimum radial distance from the hard disk drive for the discharge nozzle area of coverage and ceiling height. Provide this in accordance with the FM Approved manufacturer's design, installation, operation and maintenance (DIOM) manual or acoustic calculation method.
3. When the noise level or sound pressure level threshold for damaging the HDD is not available, use 100 dB in the calculation of the minimum radial nozzle distance.
4. For inert gas fire extinguishing systems, when possible use discharge times from 60 seconds to 120 seconds.

C. When a FM Approved noise reducing discharge nozzle is not available as a component of the clean agent fire extinguishing system, install the clean agent fire extinguishing system as follows to decrease sound pressure levels:

1. Decrease the rate of flow of fire extinguishing system from the discharge nozzles used by increasing the number of nozzles for a reduced area of coverage per nozzle.
2. When possible, provide discharge nozzles at a minimum of distance of 6.5 ft (2 m) for small orifice (3 - 8 mm) discharge nozzle(s) and 9.8 ft (3 m) for large orifice (15 - 20 mm) away from the server racks.
3. For inert gas systems, use discharge times from 90 seconds to 120 seconds.
4. Provide the minimum nozzle pressure allowed by the FM Approval listing.
5. Ensure the noise pressure level of the peak nozzle pressure is below the allowable threshold of the HDD equipment. When the allowable noise level or sound pressure level threshold for the HDD is not available use 100 dB in the assessment.

D. Do not use pneumatic sirens as an alarm notification device.

E. Provide a Business Continuity Plan for any hard disk drives that are susceptible to disruption of performance by noise from the discharge of a halocarbon or inert gas (clean agent) fire extinguishing system in accordance with Section 2.7.5.

See Section 3.3.3.3.7 for additional guidance.

2.4.4.4.9 When used in conjunction with a preaction sprinkler system, actuate the halocarbon or inert gas (clean agent) fire extinguishing system or hybrid (water and inert gas) fire extinguishing system using an FM Approved, intelligent, high-sensitivity spot smoke detection system in a matrix or counting configuration.

2.4.4.4.10 Design and install FM Approved VEVFD detection for the actuation of the halocarbon or inert gas (clean agent) fire extinguishing system(s) in accordance with Data Sheet 5-48, *Automatic Fire Detection*, and the manufacturer's design, installation, and operation manual included with the FM Approval listing.

2.4.4.4.11 Do not use standard response smoke detectors for the actuation of halocarbon or inert gas (clean agent) fire extinguishing systems.

2.4.4.4.12 When a halocarbon or inert gas (clean agent) fire extinguishing system or hybrid (water and inert gas) fire extinguishing system is actuated by air-aspirating VEWFD, do the following:

- A. Annunciate all alert, pre-alarm and alarm conditions to a constantly attended location.
- B. Provide a local visual and/or audible alarm within the protected area.
- C. Provide an alarm signal to the building fire alarm control panel area when any level (e.g., pre-alarm, actuation) of smoke detection signal is received from the smoke detection system.
- D. Arrange for the following to occur upon alarm for discharge of the halocarbon or inert gas (clean agent) fire extinguishing system:
  1. Shut down HVAC systems that:
    - a. Supply outside make-up air (external from protected room)
    - b. Are protecting combustibles only below the raised floor or only above the ceiling space
    - c. Provide forced air distribution between multiple zones
  2. Automatically close fire and smoke dampers, as appropriate.
  3. Power down data processing equipment as appropriate (see Section 2.3.5.4).
  4. Discharge the clean agent after a non-recycling time delay not exceeding 30 seconds.

2.4.4.4.13 When a halocarbon or inert gas (clean agent) fire extinguishing system or hybrid (water and inert gas) fire extinguishing system is actuated by intelligent high-sensitivity spot smoke detection, do the following:

- A. Annunciate all alert, pre-alarm or alarm conditions to a constantly attended location.
- B. From activation of the first spot smoke detector, provide local visual and/or audible alarm within the protected area.
- C. From activation of the second spot smoke detector for discharge of the halocarbon or inert gas (clean agent) fire extinguishing system, arrange for the following to occur:
  1. Shut down HVAC systems that:
    - a. Supply outside make-up air (external from protected room)
    - b. Have a clean agent fire extinguishing system protecting combustibles only below the raised floor or only above the ceiling space.
    - c. Provide ventilation between multiple zones
  2. Close fire and smoke dampers upon activation of the second detector.
  3. Power down data processing equipment as appropriate. (See Section 2.3.5.4).
  4. Discharge the clean agent after a non-recycling time delay not exceeding 30 seconds.

2.4.4.4.14 For HVAC systems that do not introduce makeup (outside) air, the forced air distribution system does not need to be shut down when both of the following are provided:

- A. A cooling air system that only recirculates air within the data processing equipment space (e.g., CRAH and CRAC) unless the data processing equipment is interlocked to shut down on agent discharge.
- B. Sufficient clean agent is provided for the volume of HVAC system ducts and components open to the protected space as part of the total hazard volume.

2.4.4.4.15 Provide permanently connected clean agent supply cylinder(s) as a reserve for the halocarbon or inert gas (clean agent) fire extinguishing system or hybrid (water and inert gas) fire extinguishing system when:

- A. Providing sole protection of the data center or data processing equipment room (see Section 2.3.2)
- B. Providing simultaneous supplementary equipment protection of multiple data processing equipment rooms

2.4.4.4.16 Provide an FM Approved fire extinguishing system releasing device that is electrically compatible with the halocarbon or inert gas (clean agent) fire extinguishing system or hybrid (water and inert gas) fire extinguishing system actuation device and that interfaces with the smoke detection and fire alarm systems.



2.4.4.4.17 Locate abort switches, when provided, within the interior of the room and near a means of egress.

A. Provide a type that requires positive manual pressure to prevent discharge of the halocarbon or inert gas (clean agent) fire extinguishing system.

B. Provide manual alarm stations and emergency manual activation devices to override the abort mode to allow immediate discharge of the clean agent fire extinguishing system.

C. Provide both distinctive audible and visual indication of the halocarbon or inert gas (clean agent) fire extinguishing system in abort mode.

D. Provide a placard that identifies the abort switch and purpose.

2.4.4.4.18 Conduct a door fan test in accordance with Data Sheet 4-9, *Halocarbon or Inert Gas (Clean Agent) Fire Extinguishing Systems*, subsequent to the halocarbon or inert gas (clean agent) fire extinguishing system installation. Verify the clean agent concentration or hybrid media will be maintained at the design concentration for the recommended retention time and to analyze whether sufficient venting and/or leakage area exists not to over-pressurize the enclosure. Modify the protected space envelope and repeat the test until acceptable results are attained.

2.4.4.4.19 Provide a plan and means to ventilate the protected area from the discharge of either the halocarbon extinguishing agent, inert gas extinguishing agent, or hybrid media and byproducts of decomposition without contamination to other equipment and areas.

## 2.5 Equipment and Processes

### 2.5.1 Mobile/Modular Data Centers

#### 2.5.1.1 Construction

2.5.1.1.1 Build the structure, exterior enclosure, and interior surfaces using noncombustible materials. If the mobile/modular data center is insulated, provide noncombustible or FM Approved Class 1-rated insulation.

2.5.1.1.2 Structurally connect containers when configured in a vertical array.

#### 2.5.1.2 Exposures

##### 2.5.1.2.1 Interior Installations

When the mobile/modular data center is installed in a building, provide automatic sprinkler protection for the hazards associated with the enclosing building construction, the exterior of the mobile/modular data center, and other contents in the enclosing building in accordance with the applicable occupancy-specific data sheet.

##### 2.5.1.2.2 Exterior Installations

When a mobile/modular data center is exposed to weather conditions, design, construct, install, and operate modules to meet the recommendations in applicable natural hazards data sheets, including, but not limited to, the following:

- Data Sheet 1-28, *Wind Design*
- Data Sheet 1-34, *Hail*
- Data Sheet 1-54, *Roof Loads for New Construction*
- Data Sheet 5-11, *Lightning and Surge Protection for Electrical Systems*
- Data Sheet 9-18, *Prevention of Freeze-Ups*
- Data Sheet 9-19, *Wildland Fire*

##### 2.5.1.2.3 Natural Hazards

For both interior and exterior installations, design, construct, install, and operate modules to meet the recommendations in applicable natural hazards data sheets, including, but not limited to, the following:

- Data Sheet 1-40, *Flood*
- Data Sheet 1-2, *Earthquakes*

In addition to adhering to the recommendations in Data Sheet 1-2, *Earthquakes*, provide the following:

A. Seismic restraint to the data processing equipment and utilities in the mobile/modular data center for the forces identified in Data Sheet 1-2.

B. Seismic anchoring of the mobile/modular data center exterior enclosure to the surface (ground, floor, or other mobile/modular data centers).

### 2.5.1.3 Fire Detection

Provide fire detection systems in mobile/modular data centers in accordance with Section 2.4.3.

### 2.5.1.4 Fire Protection

2.5.1.4.1 Provide protection for mobile data centers using one of the following:

A. Halocarbon or inert gas (Clean agent) fire extinguishing system in accordance with Section 2.4.4.4, or

B. Automatic sprinklers inside the mobile/modular data center in accordance with Section 2.4.4.2, or

C. Automatic water mist systems inside the mobile/modular data center in accordance with Section 2.4.4.3.

2.5.1.4.2 When the fire protection system equipment (i.e., storage cylinders and actuation controls) is located inside the mobile/modular data center, provide manual and emergency manual actuation devices for operation outside the entrance to the mobile/modular data center.

2.5.1.4.3 Provide protection for any specific hazard(s) in an equipment module in accordance with the applicable data sheet (e.g., emergency diesel generators).

### 2.5.1.5 Equipment Power Isolation

Provide automatic interlocks and power isolation to de-energize equipment in accordance with Section 2.3.5.4.

## 2.5.2 Network/Broadcast Control Rooms

This section provides recommendations for monitoring operations, network operations centers, broadcast, and other similar control rooms. For these occupancies, the following recommendations take precedence over other recommendations within this data sheet.

### 2.5.2.1 Materials

2.5.2.1.1 Use noncombustible materials to construct control rooms.

### 2.5.2.2 Cables

2.5.2.2.1 Use FM Approvals Group 1 or plenum-rated cable in accordance with Section 2.2.7.

2.5.2.2.2 Seal all cable and signal wire penetrations with FM Approved penetration seals with fire ratings equal to those of the surrounding construction.

### 2.5.2.3 Protection

2.5.2.3.1 Provide sprinkler design demands, hose demands, and duration in accordance with the recommendations for an HC-1 hazard category in Data Sheet 3-26, *Fire Protection Demand for Nonstorage Sprinklered Properties*.

2.5.2.3.2 Protect grouped cables and cable trays in accordance with Data Sheet 5-31, *Cables and Bus Bars*.

2.5.2.3.3 Provide automatic smoke detection in the following places:

A. In control rooms, including control panels that extend to or near the ceiling

B. Beneath raised floors and above suspended ceilings that contain a significant quantity of combustible grouped cables

C. In large cabinets with either combustible construction or combustible cables

2.5.2.3.4 Install FM Approved smoke detection in accordance with Data Sheet 5-48, *Automatic Fire Detection*.



### 2.5.3 Diagnostic Equipment

The recommendations in this data sheet for diagnostic equipment are intended for protection of the equipment.

2.5.3.1 Locate and protect the diagnostic equipment from flood and storm water runoff in accordance with Section 2.2.12.

2.5.3.2 Do not locate roof drains, domestic water lines, or other liquid piping that is not essential for operations in the diagnostic equipment room.

2.5.3.3 Provide automatic wet sprinkler protection throughout the building in which the diagnostic equipment (e.g., magnetic resonance imaging [MRI], computerized axial tomography [CAT] scan, Cyclotron) is located in accordance with the appropriate occupancy per Data Sheet 3-26, *Fire Protection Demand for Nonstorage Sprinklered Properties*.

2.5.3.4 Provide FM Approved smoke detection in accordance with Data Sheet 5-48, *Automatic Fire Detection*.

2.5.3.5 Provide an automatic sprinkler system, wet or preaction, throughout diagnostic equipment areas.

2.5.3.5.1 Provide sprinkler design demands, hose demands, and duration for hazard category 1 (HC-1) up to a 30 ft (9 m) ceiling in accordance with the recommendations in Data Sheet 3-26, *Fire Protection Demand for Nonstorage Sprinklered Properties*.

2.5.3.5.2 Use FM Approved sprinklers constructed of nonferrous material.

2.5.3.5.3 Provide automatic quick-response (QR) sprinklers with a temperature rating of 165°F (74°C).

2.5.3.5.4 Provide sprinkler spacing in accordance with Data Sheet 2-0, *Installation Guidelines for Automatic Sprinklers*.

2.5.3.5.5 Install nonferrous piping (e.g., copper, stainless steel, CPVC plastic) for the automatic sprinkler system with dielectric fittings in the diagnostic equipment area.

2.5.3.5.6 When plastic pipe is used, install it as follows:

A. Use FM Approved CPVC pipe with a wet sprinkler system.

B. Verify the diagnostic equipment hazard is similar to a Hazard Category 1 (HC-1) occupancy as identified in Data Sheet 3-26, *Fire Protection Demand for Nonstorage Sprinklered Properties*.

C. In accordance with the recommendations for CPVC pipe in Data Sheet 2-0, *Installation Guidelines for Automatic Sprinklers*.

2.5.3.5.7 If installing a preaction sprinkler system, install it in accordance with Section 2.4.4.2.

2.5.3.6 Provide protection of a control room for diagnostic equipment in accordance with Section 2.5.2.

2.5.3.7 Provide portable fire extinguishers in accordance with Section 2.4.2 and this section.

2.5.3.7.1 When magnetic diagnostic equipment is present, provide the following:

A. A portable fire extinguishers with non-magnetic construction.

B. Verification that the magnetic force rating of the portable fire extinguisher is compatible with the maximum magnetic force of the diagnostic equipment such that it does not pose a magnetic hazard.

C. Verification that the portable fire extinguisher is located no less than the manufacturer's minimum specified distance from the magnetic diagnostic equipment.

### 2.6 Inspection, Testing, and Maintenance

Establish and implement a data center utility and support system equipment inspection, testing, and maintenance program, including electrical, HVAC and all support systems. See Data Sheet 9-0, *Asset Integrity*, for guidance on developing an asset integrity program.

### 2.6.1 Heating, Ventilation and Air Conditioning (HVAC)

A. Inspect, test, and maintain HVAC systems and controls for data processing equipment spaces per equipment manufacturer's recommendations. See Data Sheet 1-45, *Air-Conditioning and Ventilation Systems* and Data Sheet 7-13, *Mechanical Refrigeration*. Also see Data Sheet 13-24, *Fan and Blowers*, for fan guidance. For cooling tower guidance, see Data Sheet 1-6, *Cooling Towers*.

B. When ventilation interlocks are provided to reduce air flow, test the interlock between the fire protection and ventilation system on an annual basis.

C. Liquid Systems: Inspect, test, and maintain piping systems as part of the asset integrity program to verify piping integrity. See Data Sheet 1-24, *Protection Against Liquid Damage in Light-Hazard Occupancies*, for guidance on mitigating damage associated with a liquid release.

D. Filters: Clean or replace HVAC filters on a regular schedule and as needed to maintain efficiency and prevent dust and lint accumulations (See Data Sheet 1-45, *Air Conditioning and Ventilation Systems*).

E. Drains: Develop a procedure for recording inspection and cleaning of HVAC drains on a regular basis.

### 2.6.2 Fire Protection

2.6.2.1 Inspect and test the various fire protection system(s) in accordance with the applicable recommendations in Data Sheet 2-81, *Fire Protection System Inspection, Testing and Maintenance and Other Fire Loss Prevention Inspections*.

2.6.2.2 Where a preaction valve is used, provide a test discharge line (see Figure 2.4.4.2.3.D) to verify operation of the preaction valve of the sprinkler system and to ensure the preaction system piping is arranged to keep water from entering the piping system.

A. During the test, close the trip test cutoff indicating valve on the system riser and open the indicating valve on the discharge test line.

B. Actuate the preaction system in conjunction with smoke detection system.

C. Immediately following the test, return the system to normal position.

D. Use FM's Red Tag Permit System when the trip test cutoff indicating valve is closed, and follow the precautions for fire protection being out of service described in Data Sheet 2-81.

E. When disabling the detection system for other testing of the preaction sprinkler system this is regarded as an impairment of fire protection.

2.6.2.3 If a flushing investigation is recommended in accordance with Data Sheet 2-81, use a videoscope inspection to verify there is no scale or debris in the piping that could clog a sprinkler. Only use this inspection method if a satisfactory water delivery time was confirmed during the acceptance test.

2.6.2.4 Test the VEWFD system annually to verify proper operation in accordance with the applicable recommendations in Data Sheet 5-48, *Automatic Fire Detection*, and Appendix C (typical test method).

2.6.2.5 Inspect the integrity of the enclosure protected by a halocarbon or inert gas (clean agent) fire extinguishing system to determine if:

A. changes have occurred that could change volume, hazard, or both.

B. penetrations have occurred that could lead to extinguishing agent leakage.

2.6.2.5.1 If an administrative control program is used to document the enclosure integrity, inspect the enclosure every 36 months. If an administrative control program is not used, inspect at least once every 12 months.

2.6.2.5.2 Use a blower door fan unit to verify extinguishing agent concentration will be maintained if uncertainty exists about the integrity of the enclosure.

2.6.2.6 Maintain fire protection systems in accordance with the applicable recommendations in Data Sheet 2-81, *Fire Protection System Inspection, Testing and Maintenance and Other Fire Loss Prevention Inspections*.

2.6.2.7 Manage impairments identified by periodic inspections, testing, and maintenance in accordance with the recommendations in Data Sheet 2-81, *Fire Protection System Inspection, Testing and Maintenance and Other Fire Loss Prevention Inspections*.

### 2.6.3 Electrical Power Distribution

2.6.3.1 Inspect, test, and maintain switchgear and battery systems in accordance with Data Sheet 5-19, *Switchgear and Circuit Breakers*, and power distribution transformers in accordance with Data Sheet 5-4, *Transformers*.

2.6.3.2 Inspect, test, and maintain electrical equipment, including automatic transfer switches in accordance with Data Sheet 5-20, *Electrical Testing and UPS Systems*, in accordance with Data Sheet 5-28, *DC Battery Systems*.

2.6.3.3 Inspect, test, and maintain emergency power systems in accordance with Data Sheet 5-23, *Design and Protection for Emergency and Standby Power Systems*, Data Sheet 13-26, *Internal Combustion Engines* and Data Sheet 5-28, *DC Battery Systems*.

2.6.3.4 Verify a documented inspection, testing and maintenance plan is in place for any portion of the electrical system operated by the utility on site.

## 2.7 Human Element

Develop, maintain, and train operators on standard and emergency operating procedures for utility and support system equipment. See Data Sheet 10-8, *Operators*, for guidance on developing operator programs.

### 2.7.1 Facilities

#### 2.7.1.1 Housekeeping

Provide procedure(s) for regular housekeeping inspections with the following goals:

- A. Potential ignition sources are controlled (e.g., smoking, hot work, temporary heaters, cooking equipment).
- B. The accumulation of combustible materials is prevented.
- C. Ordinary combustibles are not stored inside or behind control cabinets.
- D. Necessary routine spare parts, manuals, etc. are kept in normally closed metal cabinets.

#### 2.7.1.2 Penetrations

A. Develop procedure(s) to manage the state of penetrations within the data center to control smoke and liquid damage and maintain the construction fire-resistance rating. At a minimum, include the following:

- 1. Location of the current or new penetration to be opened
- 2. Issuance of a permit for the opening of the penetration
- 3. Confirmation the work is completed and penetration is sealed or resealed
- 4. Removal and retention of the permit as a record of the work
- 5. Periodic audits of penetration locations to determine the procedure is being followed

B. Verify the integrity of penetration sealing on a minimum yearly basis.

C. Seal new penetrations identified from inspection or penetrations having compromised integrity in accordance with Section 2.2.4, Penetrations.

#### 2.7.1.3 Cables

2.7.1.3.1 Develop a Management of Change (MOC) policy to document the type/markings (e.g., plenum rated) of new communication and data cables (e.g., coaxial and fiber optic) and power cables that can be installed.

#### 2.7.1.4 Hot Work Management

2.7.1.4.1 Develop a hot work management program in accordance with Data Sheet 10-3, *Hot Work Management*.

### 2.7.2 Emergency Response Team (ERT)

2.7.2.1 Use Data Sheet 10-1, *Pre-Incident and Emergency Response Planning*, as a resource to develop a plan and procedures.

2.7.2.2 Provide emergency response personnel with, at minimum, procedures for and authorization to do the following:

- A. Interrupt electrical power at the ignition source as outlined in the power isolation plan (see Section 2.7.3).
- B. Isolate leaking water used for cooling of data processing equipment at the closest control valve. Use Data Sheet 1-24, *Protection Against Liquid Damage in Light-Hazard Occupancies*, as a resource to develop a plan and procedures.
- C. Notify the fire service.
- D. Operate extinguishing equipment.

2.7.2.3 Develop a pre-incident plan with the local fire service. At a minimum the plan should include the following:

- A. A tour
- B. A description of the facilities and equipment
- C. Implementation of the power isolation plan

2.7.2.4 Use Data Sheet 9-1, *Supervision of Property*, as a resource to develop a plan and procedures to prevent unauthorized access the premises and assets.

### 2.7.3 Power Isolation Plan

2.7.3.1 Develop a detailed power-isolation plan that includes formal procedures for de-energizing data and/or HVAC equipment to reduce damage, contamination from smoke, and prevent reignition. The goal of the procedures should be to selectively isolate equipment within an affected cabinet, row, or zone, and to enable personnel to respond to an event requiring complete power isolation of a room or building in a timely but expeditious sequence to prevent propagation and reignition. Power isolation at the room level should be initiated when the fire protection system(s) activate.

When a manual power isolation plan is to be implemented, disconnect power to affected energized sources on as local a level as possible based on current conditions while still providing the ability to power down an entire room if necessary.

2.7.3.2 At a minimum, include the following items in the power-isolation plan:

- A. A description (for the ERT and fire service) of the data processing equipment and HVAC systems within the building and how they are powered and isolated or de-energized. Include all sources of power, including commercial power, batteries, and generators to the fire area.
- B. The functions of disconnect controls (e.g., switch/button, circuit breaker, switch gear) for powering down or de-energizing the data processing equipment and/or HVAC system in the data center (See Section 2.7.7).
- C. The location of the manual control(s), remote manual control(s), and disconnect control(s) for powering down the data processing equipment and/or HVAC system.
- D. Label power sources to the equipment room (electrical panels, PDUs, etc.) to show the areas/equipment they control so specific equipment can be quickly located and de-energized.
- E. If multiple zones are used, identify the data processing equipment or HVAC system associated with each zone.
- F. When to use the manual remote override disconnect control for de-energizing data processing equipment and/or HVAC system.
- G. The impact from the activation of individual data processing equipment power switches.
- H. Identify the responders who are designated to do the following:

1. Isolate all sources of power, including commercial power, batteries and generators to the fire area.
2. Notify the fire service and management designated to authorize implementation of the power isolation plan from a constantly attended location.
3. Meet fire service personnel.
4. Advise the fire service personnel of power sources, disconnect controls, and depowering methods.

I. Post the following information for the fire service inside the designated entrance:

1. Floor plans
2. Contact names and phone numbers of personnel responsible for the site.
3. Location of emergency power disconnect controls

J. Pre-plan the previous items with the fire service.

K. Drill procedures with the emergency response team (ERT).

2.7.3.3 When halocarbon or inert gas (clean agent) or hybrid (water and inert gas) fire extinguishing systems are installed with automatic power-down and a controlled time delay, ensure the following, at a minimum:

- A. Manual power-down can be completed in a maximum of 10 minutes as part of the soft switch process, at which time automatic depowering of the data processing equipment is initiated.
- B. The halocarbon or inert gas (clean agent) or hybrid (water and inert gas) fire extinguishing system design concentration compensates for continuous forced-air distribution during the time delay (see Section 2.4.4.4).
- C. The design concentration for energized data processing equipment is maintained at a minimum until the controlled or automatic “soft” shut down is complete.

2.7.3.3.1 Contact the data processing equipment manufacturer for assistance in the powering down of data processing equipment and the appropriate initiating device to use for automatic power down.

2.7.3.4 Review the power isolation plan at least quarterly.

2.7.3.5 Test or drill the power isolation procedures and methods at least annually with all individuals involved in the plan. *See Appendix E, Testing of Power Isolation Disconnect Control Systems, for a typical installation method to assess proper functionality.*

2.7.3.5.1 Conduct walk-through drills in which power isolation is simulated for different fire scenarios and fire propagation levels.

2.7.3.6 Train designated responder(s) to properly operate circuit breakers and disconnect equipment.

#### 2.7.4 Disaster Recovery Plan

2.7.4.1 Develop a detailed written disaster recovery plan for the data center based upon a complete loss of facility and services.

2.7.4.2 Develop the disaster recovery plan based on the applicable recommendations in Data Sheet 10-5, *Disaster Recovery Planning*.

2.7.4.3 Annually review and test the plan to ensure it is up to date and functional.

#### 2.7.5 Business Continuity Plan

2.7.5.1 Develop a detailed written business continuity plan based on a complete loss of facilities or services. Address the following in the plan:

- Executive management support
- Utilization/relocation of personnel
- Facilities, equipment (including equipment contingency planning, service interruption planning, and power isolation planning)
- IT/telecom
- Suppliers
- Clients
- Plan implementation and testing

2.7.5.2 Review and test the plan annually to ensure it is up to date and viable.

### 2.7.6 Flood Emergency Response Plan

For locations in which the predicted 500-year flood will result in onsite flooding, develop a detailed written flood emergency response plan (FERP) for the data center and related facilities using the applicable recommendations in Data Sheet 10-1, *Pre-Incident Planning*.

### 2.7.7 Contingency Plan

#### 2.7.7.1 Equipment Contingency Planning (ECP)

When a data center utility and/or support system equipment breakdown results in an unplanned outage to site processes and systems considered key to the continuity of operations, develop and maintain a documented, viable utilities and support system equipment contingency plan (ECP) per Data Sheet 9-0, *Asset Integrity*. See Appendix C of that data sheet for guidance on the process of developing and maintaining a viable equipment contingency plan. Also refer to sparing, rental, and redundant equipment mitigation strategy guidance in that data sheet.

To develop the data center ECP, conduct a systematic, strategic assessment of data center utilities and support system equipment. Consider process bottlenecks, single points of failure, unique and long lead time equipment, evaluate equipment integrity, reliability and remaining useful life, fitness for service, and operating history/trends. Evaluate the type and scope of ECP needed to mitigate the equipment specific breakdown exposures.

The data center ECP includes recovery options and mitigation strategies to respond to and recover from the equipment breakdown exposures, focusing on electrical and cooling equipment. This can include repair, replacement, rental lead time options, used and/or surplus equipment, redundancy, and sparing to minimize the downtime.

Consider the impact of the failure of an automatic transfer switch (ATS) or emergency/standby power systems and switchgear when evaluating equipment contingency plans.

2.7.7.2 For loss of cooling to data center equipment due to a cooling support system equipment breakdown, the overall objective of the ECP for this scenario is to shut down data processing equipment in an orderly manner upon loss of cooling, or impending loss of cooling, before the temperature exceeds the facility's or the manufacturer's guidelines, including warranty restrictions (i.e., thermal runaway).

For loss of cooling, the ECP should consider operations, sensors and alarms, and response capabilities of emergency and operating personnel. Include the criticality of the data processing functions and an understanding of the time available to become aware of developing overheating situations, make decisions, and take actions to prevent data processing equipment damage from overheating.

2.7.7.3 In addition, evaluate the following elements in the contingency planning process specific to equipment breakdown resulting in loss of cooling to data center processing equipment:

- A. Data from the original equipment manufacturer's (OEM) literature for all critical data processing equipment components. Include warranty thresholds, recommended maximum short-term operating temperatures, and automatic equipment shutdown interlocks provided by the OEM due to excess temperatures in all data processing equipment (power supplies, servers, data storage equipment, etc.).
- B. Calculations by qualified design professionals involving the nature of the cooling equipment, the room and surroundings, and data processing equipment, to determine the expected room temperature rate of rise on loss of cooling, assuming continued operation of the data processing equipment.
- C. The probable time to data processing equipment damage due to temperatures exceeding critical thresholds. Include at least the following input: data processing equipment individual heating characteristics, electrical power input to the data processing equipment room, data processing equipment space volume and height, normal data processing equipment space operating temperature, any partial cooling from the cooling equipment connected to standby power.
- D. Using the information in A through C, develop the following scenarios, at a minimum, in the ECP at several levels of temperature threshold alarms, with the mitigation actions to be taken at each level:
  1. Short-term (~51 sec), medium-term (~51 min), and long-term (~51 hr) interruptions of utility power to the entire facility (See 2.7.8 for Service Interruption Planning).



2. Breakdown of a single critical cooling system component, such as chillers, chilled water pumps, condenser water pumps, cooling tower fans, air handler fans (e.g., bearing seize), cooling media control valves (e.g., failing closed), cooling system local and centralized controls, variable speed drives, and electric power (e.g., circuit breakers) for any of the above equipment.

3. Additional breakdown scenarios as needed based on a review of the facility's unique design, arrangement, and operation.

E. The time necessary to provide sufficient cooling to the data processing equipment space following short-term power loss to the facility, followed by power restoration, to avoid data processing equipment overheating damage. Include at least the following input: time to start standby power generators, cooling equipment connected to the standby power and time to start cooling equipment (e.g., controls, chillers, pumps, cooling towers, CRAH, etc.).

F. Guidance if initial mediation efforts are not successful and the data processing equipment space temperature continues to rise, including interrupting power to the data processing equipment (e.g., main power, emergency power, facility UPS, and equipment based UPS) in accordance with the data processing equipment power isolation plan.

2.7.7.4 Implement the loss-of-cooling ECP using the following elements:

A. Training: Provide plan training to facility operations personnel and data processing equipment operations personnel.

B. Authority: Designate at least one person per shift to have the authority to implement the ECP including the data processing equipment power isolation plan (Section 2.7.3), if data processing equipment shutdown is needed to prevent damage.

C. Operation: Designate personnel on each shift to perform the steps in the loss of cooling equipment contingency plan.

D. Practice:

1. Review, test, and validate the loss-of-cooling equipment contingency plan at least annually to confirm efficacy.
2. Practice recovering cooling to the data processing equipment, including starting emergency generators, shifting critical equipment operation to backup (N+1) components, restarting HVAC equipment (CRAH, chillers, pumps, cooling towers, controls, etc.).
3. Practice the real-time decision path in identifying situations in which cooling cannot be restored before the data processing equipment incurs critically high temperatures, resulting in the decision to shut down the data processing equipment.
4. Practice the actions required to interrupting power to the data processing equipment in accordance with the power isolation plan to ensure the required timeframe is met.

2.7.7.5 Review and validate the ECP annually and when there are significant changes on site to manage change and confirm efficacy of the plan.

### 2.7.8 Service Interruption Plan

2.7.8.1 When the loss of utility and/or support system services for a data center results in an unplanned outage to site processes and systems considered key to the continuity of site operations, develop and maintain a documented, viable service interruption plan (SIP).

To develop the data center SIP, conduct a systematic, strategic assessment of data center utilities and support system services to identify in advance the impact of and response to loss of the services. Consider recovery from damage to utilities and support system equipment, and impact of the loss of the process/equipment operating conditions and environment. Consider the timeline for an orderly shutdown and isolation of equipment per the documented emergency operating procedures and the power isolation plan, evaluate the state of the equipment and then restart and restore full operations per the documented standard operating procedures.

2.7.8.2 The data center SIP includes recovery options/mitigation strategies to respond to and recover from the loss of services to mitigate the exposure. In addition, evaluate the following elements in the SIP process specific to data center utility system electrical services:

- A. Electrical service (see Section 2.3.5.2)
  - 1. System design/redundancy for critical electrical paths
    - a. Single points of failure
    - b. Critical load flexibility, continuity
    - c. Power isolation
    - d. Outage duration: Short-term (~51 sec), medium-term (~51 min), and long-term (~51 hr) interruptions of utility power to the entire facility
  - 2. Capabilities, viability of the emergency power system
    - a. Emergency or standby generators
    - b. UPS
    - c. Orderly shutdown
    - d. Duration of operation
    - e. Fuel supply/replenishment for expected duration
- B. Loss of cooling due to loss of electrical service (see Section 2.3.5.3)
  - 1. System design/redundancy for critical cooling paths

2.7.8.3 Review and validate the SIP annually and when there are significant changes on site to manage change and confirm efficacy of the plan.

### 2.7.9 Security

2.7.9.1 Design buildings for security in accordance with Data Sheet 9-1, *Supervision of Property*, and recommendations in this section.

2.7.9.2 Establish a procedure and method, such as card access, to verify that an individual entering the facility is authorized to do so.

2.7.9.3 Have entrances to buildings and floors secured, and use a secure access system to verify employees and visitors.

2.7.9.4 Limit unescorted visitors in unsecured, open areas. Have visitors escorted to all other areas.

2.7.9.5 Admit only authorized personnel to the data processing equipment room and other critical areas (e.g., cartridge storage rooms, UPS rooms, battery rooms, network/fiber room, switchgear). Keep these areas secured with locks or electronic key systems.

2.7.9.6 Protect routine spare electronic components, such as circuit boards, from theft (see Data Sheet 9-16, *Burglary and Theft*).

2.7.9.7 Verify authorized personnel have access (e.g., master key, passcode) to equipment protected by locks in order to gain access in the event of a fire.

2.7.9.8 Install an FM Approved Level 1 or better intrusion alarm system for data and record storage rooms, if these areas are provided with emergency doors exiting outside the secure area.

2.7.9.9 Install an FM Approved Level 2 or better intrusion alarm system, if previous experience indicates this need (see Data Sheet 9-16, *Burglary and Theft*).

2.7.9.10 Provide the alarm system with line supervision or a loud local alarm, and provide a response level that meets a response specification of FM-15 per Data Sheet 9-16, *Burglary and Theft*.

2.7.9.11 See Data Sheet 9-16, *Burglary and Theft*, for additional details regarding the recommendations above and for additional recommendations related to the installation of an intrusion alarm system.

2.7.9.12 Provide a procedure and method for preventing contractors who are performing equipment maintenance on computers from introducing a cyber risk (e.g., viruses, malware) to the information technology network.



2.7.9.13 Provide a procedure and method for physical destruction of data storage devices (e.g., hard disk drives) that are no longer in service.

### 3.0 SUPPORT FOR RECOMMENDATIONS

#### 3.1 Construction and Location

##### 3.1.1 General

Data centers are complex facilities with both active and passive fire protection systems, along with critical support equipment to keep the facility operational. A total building commissioning program may be warranted to assist in the quality control for construction and operational functionality of the occupancy. The following documents provide guidance in the development of a commissioning program:

- NFPA 3, *Recommended Practice for Commissioning and Integrated Testing of Fire Protection and Life Safety Systems*
- NFPA 4, *Standard for Integrated Fire Protection and Life Safety System Testing*
- American Society of Heating, Refrigerating and Air-Conditioning Engineers (ASHRAE) Commissioning Guideline 0-2005.

Data centers located below-grade are susceptible to water ingress (surface, storm, and/or flooding).

##### 3.1.2 Penetrations

The objective of sealing penetrations is to prevent smoke from a fire in adjacent spaces from entering the data processing equipment space, and to hold a clean agent concentration, if applicable.

Fire-resistance-rated penetration seals do not prevent the passage of smoke until the seal expands when exposed to heat from the fire. A penetration seal with a leakage rating will limit the passage of smoke before the seal is exposed to high temperatures. Laboratory leakage tests are conducted at ambient and at 400°F (204°C).

##### 3.1.3 Cables

Cables listed to UL 910 are marked with an identification code.

Power cables and junction boxes for power cables with chlorinated polyethylene or polyvinyl chloride (PVC) sheathing, insulation, or construction when involved in a fire or electrical fault could produce hydrochloric acid (HCL) gas at levels sufficient to produce smoke damage and corrosion to the data processing equipment and other equipment.

##### 3.1.4 Insulation

For moisture/condensation control reasons, elastomeric and neoprene rubber are sometimes placed on the underfloor of the raised floor space.

##### 3.1.5 Earthquake

Earthquake requirements and testing for telecommunications equipment are described in NEBS Requirements: Physical Protection, Telcordia Technologies GR-63-CORE. Equipment is not listed or labeled, so it cannot be determined whether equipment has been tested to these requirements.

The NEBS standard is based on testing the equipment using a synthesized waveform and earthquake response spectra for the purposes of confirming equipment functionality as well as overall restraint of the equipment cabinet/rack.

## 3.2 Occupancy

### 3.2.1 Data Processing Equipment Rooms

The type of fire detection and fire protection system chosen should be based upon an evaluation of the complete occupancy. The level of protection should consider, at a minimum, the building construction and contents, building infrastructure, equipment materials of construction, and exposures.

### 3.2.2 Raised Floor and Above-Ceiling Areas Containing Cable

FM Approved water mist systems listed specifically for protection of cables below raised floors have two different design methods: (1) area of coverage and (2) local application. The area of coverage design uses a square nozzle spacing throughout the entire below raised floor area regardless of cable tray location. The local application design uses linear spacing and is intended to protect the specific length of cable tray. Either design can be used alone or in conjunction with the FM Approved "above-floor protection" design. The FM Approval listing for below raised-floor protection will designate the number of cable tray tiers it has been evaluated to adequately protect.

### 3.2.3 Hot/Cold Aisle Containment and Hot Collar Systems

3.2.3.1 Hot/cold aisle containment (see Figures 2.3.2.4.10.A, B and C), particularly at the ceiling, presents challenges to fire protection in data processing centers. Among the concerns for this occupancy are:

- Shielding and obstruction of ceiling sprinklers
- Shielding and obstruction of smoke detection systems
- Failure of halocarbon or inert gas extinguishing agents to properly penetrate the equipment beneath the containment
- Introduction of plastic combustibles into the room

3.2.3.2 The use of flexible plastics for containment is not recommended partly because flexible plastics include plasticizers, which create more corrosive smoke when burned. If flexible plastics are used for containment, the thinnest material available should be used.

3.2.3.3 Releasing device assemblies (fusible links, thermal mechanical links and mechanisms) for removable curtains, and aisle containment materials used with containment systems need to be listed by a National Recognized Testing Laboratory (NRTL) (e.g., FM Approvals) in a fire protection application. At this time, no releasing device assemblies are listed since no NRTL Standard exists. Further research and testing are required to understand the impact of activating these releasing devices without also impacting the response time of the protection system to perform effectively. The use of these devices increases the complexity to provide proper protection compared to providing additional sprinklers or clean agent nozzles.

3.2.3.4 When the room has a halocarbon or inert gas (clean agent) fire extinguishing system activated by a VEWFD detection system, consider the location of the nozzles from which the clean agent will be discharged; the nozzles should not be blocked from the containment system. Also, consider the design concentration for the protection of the containment system volume independent of the data processing equipment room in order for the proper concentration to be delivered in both areas.

3.2.3.5 Consider the type of air-handling unit (AHU) design for continuous distribution of the halocarbon or inert gas extinguishing agent to all areas of the containment aisles. The cooling air in a data processing equipment room is typically circulated in a closed loop from the air-handling unit to the equipment below the raised floor, into the return air ducts and back to the equipment. Some designs include single pass airflow, such that all cooling comes from the outside and exits the building without any recirculation. Also, some designs include options for anything from single pass to total recirculation, depending on conditions.

3.2.3.6 When evaluating the need for detection beneath a containment ceiling, keep in mind that standard-response, spot-type smoke detectors under containment ceilings and within containment curtains may be significantly impaired due to their reliance on air-flow velocity and positioning. An air-sampling, VEWFD system is more advantageous.

### 3.2.4 Servers, Mainframes, and Supercomputers

3.2.4.1 Nationally recognized testing laboratories (NRTLs) that evaluate equipment to electrical safety standards include:

- Underwriters Laboratory (UL)
- Intertek
- VDE Testing Institute
- TÜV

Electrical safety standards that help reduce the risks of fire or arcing with equipment include:

A. Underwriters Laboratories (UL)

- UL 478, *Standard for Electronic Data-Processing Units and Systems*
- UL 1950, *Standard for Safety of Information Technology Equipment*
- UL 60950, *Safety of Information Technology Equipment*
- UL 60950-1, *Information Technology Equipment - Safety - Part I: General Requirements*

B. British Standard Institute (BSI)

- BS EN 60950-1:+A12 Information technology equipment. Safety. General requirements.

3.2.4.2 Where signs of inadequate, single-point grounding have been observed, a qualified electrician or other qualified consultant should study the installation; and appropriate diagnostic and corrective actions should be taken. See Data Sheet 5-20, *Electrical Testing*, for symptoms of inadequate grounding.

Further detailed grounding information (design and installation) can be obtained from IEEE 1100 1992, *Recommended Practice for Powering and Grounding Sensitive Electronic Equipment*.

3.2.4.3 A server is a piece of data processing equipment, computer, or device (see Figure 2.3.2.5.2) that manages network resources. Servers are the backbone of the internet. They provide information in the form of text, graphics and multimedia to online data processing equipment that request data. A blade server is designed for high-density computing.

3.2.4.4 Mainframes are powerful computers used primarily by corporate and government organizations for critical applications, bulk data processing, industry and consumer statistics, search function capability and financial transaction processing. The term originally referred to large cabinets that housed the central processing unit and main memory of early computers.

3.2.4.5 Supercomputers are used in the sciences, engineering, defense intelligence, weather forecasting, etc. They utilize massive parallel processing—for example, 5,800 processors and more than a trillion bytes of RAM.

3.2.4.6 Clean agent fire extinguishing systems are provided to limit the thermal and nonthermal damage due to a fire originating within the room at an incipient stage.

### 3.2.5 Quantum Computers

Quantum computers have not yet reached full commercial viability; however, a significant amount of research and development exists in the hardware and software related to this technology. Quantum computers are most likely to be located at research establishments, universities and the research campuses of large technical organizations. Quantum computers are expensive (US\$5-10 million), and outside of their encapsulation (vacuum and cryogenic chamber) are highly susceptible to nonthermal damage. To operate, high vacuums and very low temperatures are needed to maintain stable operation of the quantum chip. Should multiple quantum computers be connected to an individual support system for vacuum, refrigeration or power, consider the impact to multiple quantum computers. Along with the quantum computer, large amounts of conventional computing power is needed to analyze and correct errors from the data generated. This conventional computing power will likely be located in server rooms or data centers away from the quantum computers.

### 3.2.6 Li-Ion Battery Backup Units in Data Processing Equipment Rooms

Data centers are moving towards battery back-up units (BBU) using Li-ion battery modules in data processing equipment rooms. Battery backup units (BBU's) are installed in data processing server racks to provide localized, uninterruptible power to the data processing equipment in the event of a main utility power failure and reduce peak power demand of the data center. BBUs are designed to be installed within a server rack in place of a server. Typical installations will have BBUs located in 2-6 server slots within a rack (see Figure

2.3.2.7.1). Each company has their own proprietary technology, arrangement, specification, battery power, quantity and layout of the BBU's within the racks. See Figure 2.3.2.7.1 for example of a rack layout containing power shelves.

Introducing Li-ion BBU's into data center presents ignition sources to the data processing equipment room that did not previously exist. This additional ignition source has the potential to increase the frequency of fire losses in this occupancy; and therefore, calls for tighter control of material flammability in the data hall (e.g., cables, cold/hot aisle separation panels, and other plastics and combustible materials on the computer servers and racks). In addition, fire intensity and severity compared to that typically expected in data processing equipment rooms without distributed power systems will be increased. With multiple BBU's installed in server racks, the potential exists for continuous thermal runaway caused by overheating of adjacent BBU's. This has the potential to cause larger more damaging fires, with the added risk of reignition following a fire event.

Halocarbon and inert gas (Clean Agent) protection systems are not recommended for BBU applications for the following reasons:

A. Efficacy relative to the hazard. As of 2019, no evidence exists that gaseous protection is effective in extinguishing or controlling a fire involving energy storage systems with Li-ion batteries. Halocarbon and inert gas (clean agent) protection systems may inert or interrupt the chemical reaction of the fire, but only for the duration of the hold time. The hold time is generally ten minutes, not long enough to fully extinguish an Li-ion battery fire or to prevent thermal runaway from propagating to adjacent modules or racks.

B. Cooling. FM research has shown that cooling the surroundings is a critical factor to protecting the structure or surrounding occupancy, because currently no way exists to extinguish an Li-ion battery module fire with sprinklers. Gaseous protection systems do not provide cooling of the Li-ion batteries or the surrounding occupancy.

C. Limited Discharge. FM research has shown that Li-ion battery fires can reignite hours after the initial event is believed to be extinguished. As gaseous protection systems can only be discharged once, the subsequent reignition would occur in an unprotected occupancy.

Battery back-up units consist of a number of individual Li-ion cells. Cells are rated in Ampere hours (Ah) and Voltage (V). To determine the kWh output per cell the following formula should be used:

$$\frac{\text{Ah} \times \text{V}}{1000\text{A}} = \text{kWh}$$

Once the kWh per cell is known, it should be multiplied by the number of cells in the module, giving the overall output per module.

The module output should then be multiplied by the number of modules per rack to determine the kWh per rack.

The output of individual BBU's should be available from the equipment operator and is usually reported as kWh for the overall unit.

### 3.2.7 Tape Cartridge Storage

An automated tape library is a hardware device that contains multiple tape drives for reading and writing data, access ports for entering and removing tape cartridges and a robotic device for mounting and dismounting the tape cartridges without human intervention. Tape cartridges are usually constructed of a plastic material and can be numerous within the tape library. When constructed of combustible material, they are a possible fuel source. The robotic devices are electrically powered and can be considered an ignition source. Hence, recommendations are provided for detection and suppression within the automated tape library equipment.

The virtual tape library (VTL) combines traditional tape backup methodology with disk technology to create backup and recovery features.

By backing up data to disks instead of tapes, VTL often increases performance of both backup and recovery operations. In some cases, the data stored on the VTL's disk array is exported to other media, such as physical tapes.

VTL disk storage is not designed to be removable. Since the disk storage is always connected to power and data sources, it is exposed to potential impact from data center interruptions.

3.2.8 Utilities

3.2.8.1 Electrical Power Distribution

3.2.8.1.1 Figures 3.2.8.1.1.a and 3.2.8.1.1.b show the typical electrical power distribution for a data center. This drawing groups electrical equipment into different spaces (electrical space, IT space, mechanical space). These spaces are typically located in different parts of the facility: The IT space is the data center equipment room, and the electrical space is the substation and switchroom. Cooling systems are usually located in the AHU or machinery room; however, cooling systems may also be located within the data center.

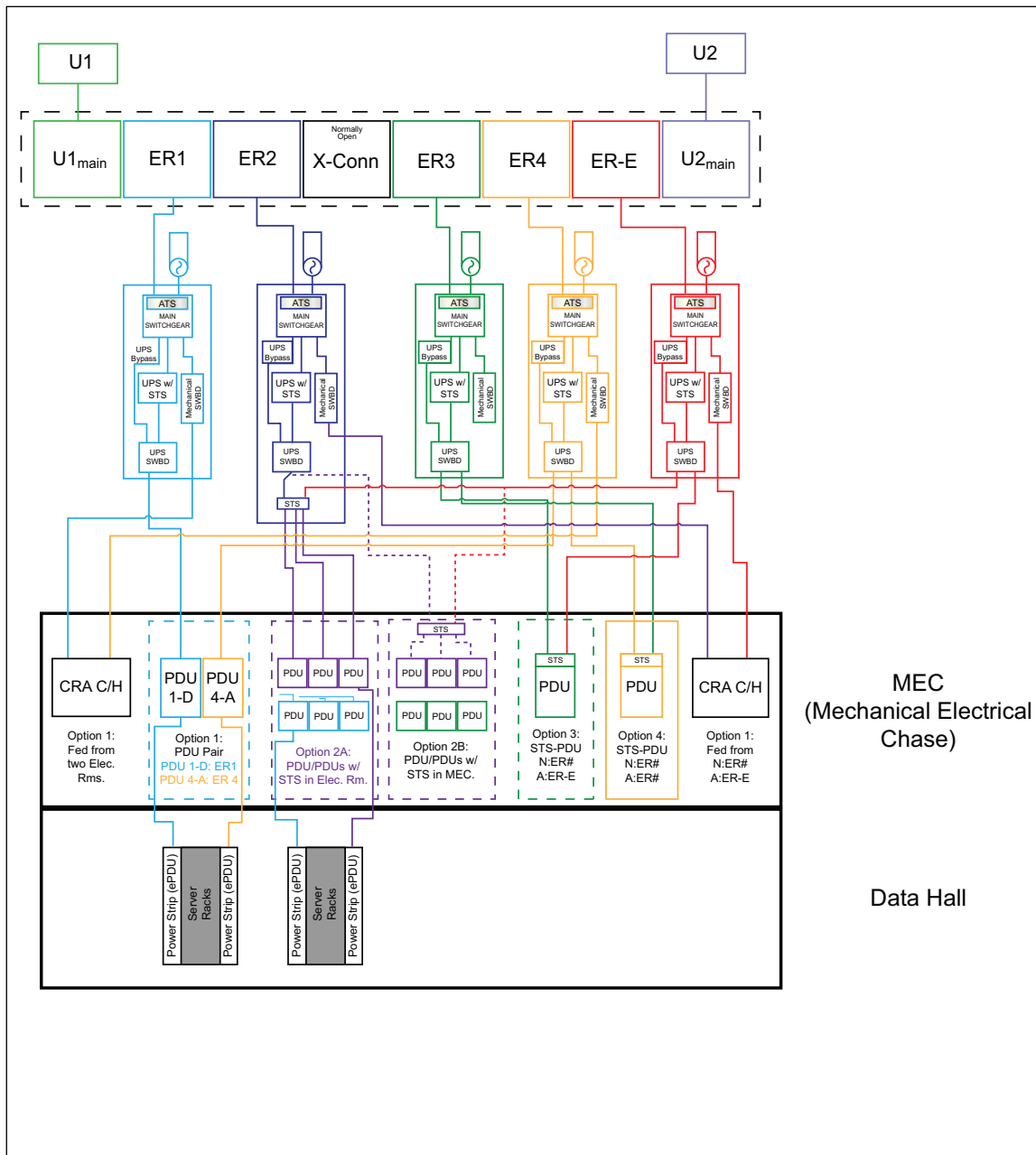

Fig. 3.2.8.1.1.a. Electrical power distribution for a data center (Redundant Distribution)

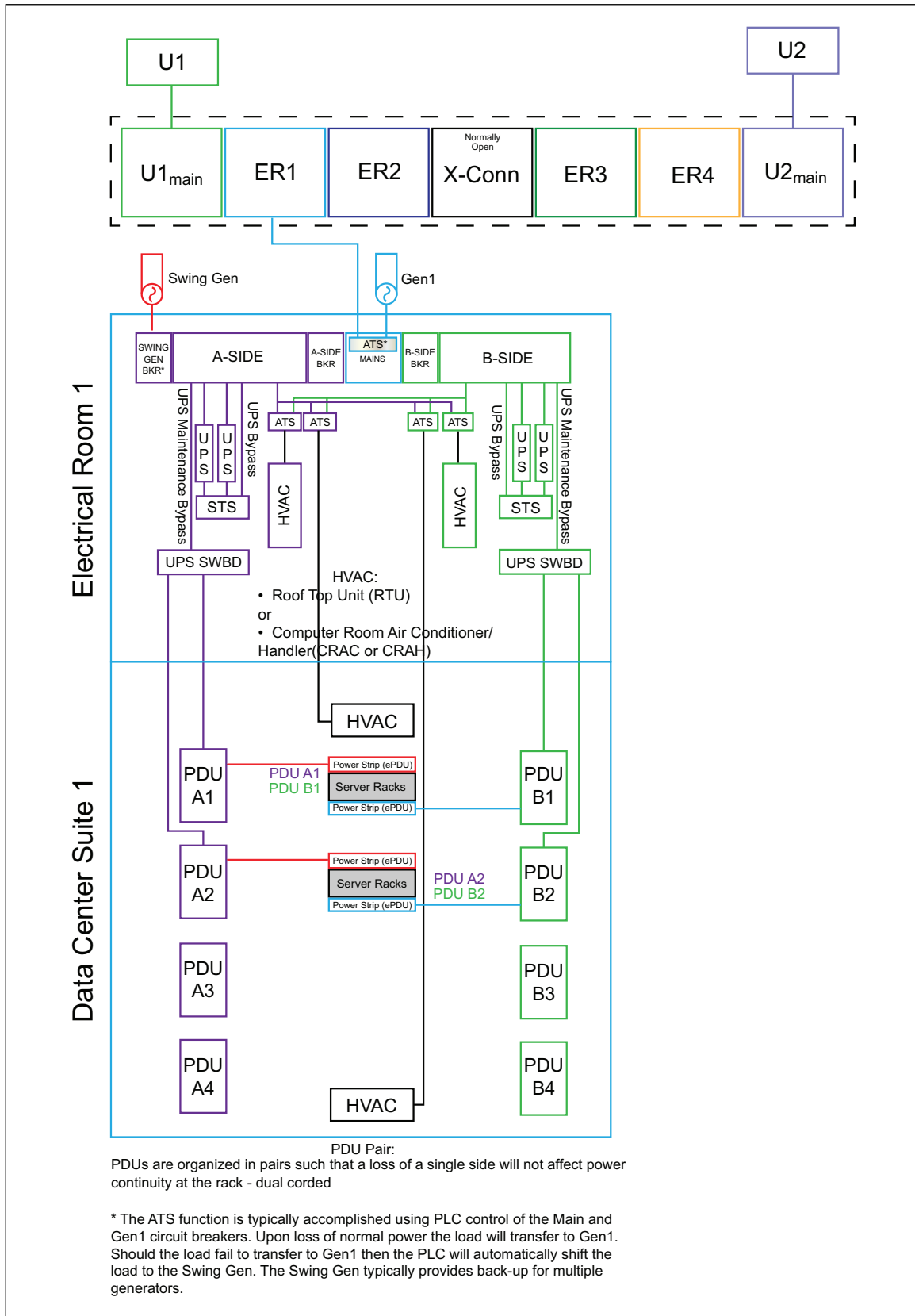

Fig. 3.2.8.1.1.b. Electrical power distribution for a data center (PDU Pairing)

Due to their large power demand, as well as the need for an electrical supply with good power quality, data centers are typically supplied by medium-voltage, three-phase power from the utility.

IT equipment operates on single-phase, low-voltage power. The three-phase medium-voltage power is stepped down to a low voltage by a facility-owned transformer to feed low-voltage switchgear.

The low-voltage supply from the transformer is typically a four-wire system with a grounded neutral. The grounded neutral is important for electrical protection as well as power quality considerations.

Because maintaining a secure power supply for the data center is important, utility power to IT equipment is supplied through uninterruptible power supplies (UPS). These UPSs are fed from the low-voltage switchboard and distribute filtered, uninterruptible power to the data center through UPS switchgear. See Figure 3.2.8.1.1.c.

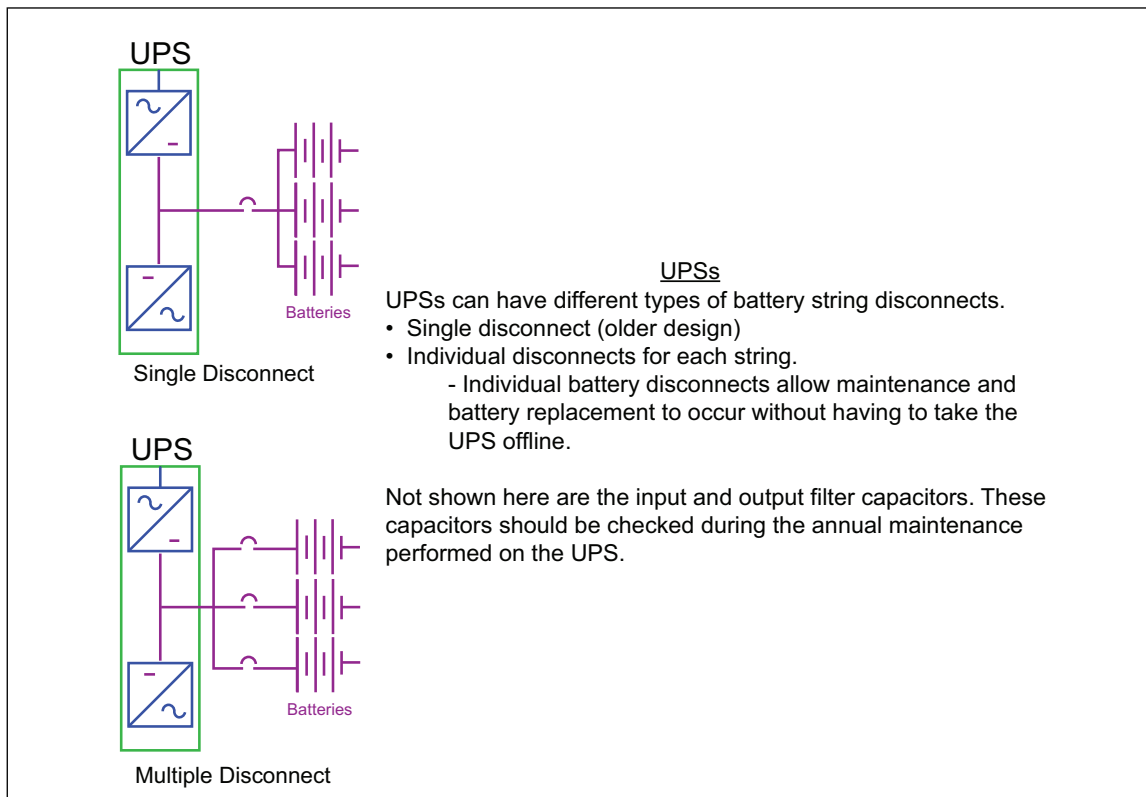

Fig. 3.2.8.1.1.c. Uninterruptible power system for a data center)

Typically, UPSs are of the static type, where utility power is used to charge batteries that take over when power is lost.

Because static UPSs have a limited power supply duration, most data centers will also have a standby diesel generator that supplies essential power to the data center for IT equipment and some lighting and cooling. This standby power may not be sufficient to run the full electrical load for auxiliary operations (e.g., offices, conference rooms) in the data center.

Some data centers may use dynamic UPSs. These are driven by a diesel generator and have a longer power supply duration. Depending on the capacity of the dynamic UPSs, having a separate emergency diesel generator may not be necessary.

In addition to IT equipment, the low-voltage switchgear in the electrical space also supplies other equipment such as the data center cooling and lighting systems. Cooling systems that have a large power demand may be fed directly from the medium-voltage switchboard.

Within the IT space, typical arrangements for supplying the racks are shown in Figures 3.2.8.1.1.a and 3.2.8.1.1.b:



A. A power distribution unit (PDU) feeding a remote power panel (RPP). The PDU typically consists of a main input circuit breaker, a transformer, panelboards, surge arrestors, output power cables, and metering and control modules. The RPP is similar to the PDU but has no transformer; it has an input circuit breaker and panelboards with metering and control modules that distribute power to the racks. The PDU and RPP are equipment cabinets that sit on the raised floor in the data center.

B. A plug-in busduct. The busduct has a feed unit connecting the bus to the upstream switchboard with plug in units directly feeding each rack. The busduct can be located overhead or under the raised floor. Metering and control functions are provided in the feed unit. When power reaches the equipment racks, a rack power distribution unit (rPDU) distributes the power to individual equipment. This is essentially a power strip into which individual IT equipment is plugged.

### 3.2.8.2 Electrical Protection for the Data Center

3.2.8.2.1 Data centers have several layers of electrical protection. These are described below, starting at the rack and working backward toward the utility supply:

A. The power supply for individual IT equipment is fitted with over-temperature, overload and short-circuit protection. This protection is primarily designed to protect the individual IT equipment from damage if a problem occurs with the power supply.

B. Rack power distribution units (rPDUs) are similar to power strips used in office and residential buildings and typically do not have any protection. Sometimes, over-temperature and overload protection is provided at the power strip.

C. Remote power panels (RPPs) have overload and short-circuit protection for each of the feeders to the rPDUs. This protection is provided at the branch circuit breakers and main circuit breaker of the RPP.

D. PDUs have overload and short-circuit protection for each of the feeders to the RPPs. Ground fault protection may also be provided at this level. If the PDU contains transformers, over-temperature and overload protection will be supplied for the transformer. This protection is available at the branch circuit breakers and main circuit breaker of the PDU.

E. The UPS distribution switchboard has overload and short-circuit protection for each of the feeders to the PDUs. Ground fault protection may also be provided at this level. In addition, protection is provided for the battery charger, inverter and rectifier.

F. The low-voltage switchboard has overload, short-circuit and ground fault protection for every feeder. This protection is provided at the main incoming LV breaker, as well as at each of the branch circuit breakers.

G. The medium voltage switchboard has overload, short-circuit and ground fault protection. Transformer protection for the MV/LV transformer is also provided. Transformer protection is provided at the circuit breakers for the utility and transformer feeders. Control and tripping power for these circuit breakers may be present. This level of electrical protection means that when electrical faults occur within the data center or within the electrical distribution system, protection will detect and remove the electrical fault by de-energizing the equipment where the fault has occurred.

3.2.8.2.2 Although a relatively high level of electrical protection exists throughout a data center, scenarios exist for which this electrical protection may not be able to detect an electrical fault and will, therefore, not de-energize the faulty equipment and remove the ignition source. These scenarios include:

A. Series arcing. Series arcing occurs when a break in the conductor or a loose connection results in a discontinuity in the circuit. If the discontinuity or break is not large enough, current will still flow across the break as an arc. Series arcing is limited to less than the load current. As a result, it will not be detected by over-current protection.

B. High-resistance parallel arcing. The other type of arcing is parallel arcing, where the insulation between energized conductors or between a conductor and ground is compromised; and current is allowed to flow as an arc. The fault current that flows during this type of arcing is very high, and short circuit protection is designed to detect and remove this type of electrical fault. However, under some circumstances where the arc resistance is high, the fault current may not be large enough to activate short circuit protection.



C. Loose electrical connections. Loose electrical connections can lead to overheating. This overheating will not be detected as an overload if the load current does not increase. Loose electrical connections are also a source of series arcing. Series arcing cannot be detected by conventional electrical protection.

D. Circuit breaker failure. Circuit breakers are mechanical devices and can fail to operate. Circuit breakers also have a limited fault-interrupting rating and may fail to properly interrupt a fault that exceeds their rating. These types of faults may also weld the contacts of circuit breakers, preventing them from opening.

E. Incorrect or faulty grounding. Grounding is critical in ensuring the correct operation and detection of electrical protection. Incorrect or faulty grounding can lead to malfunctioning electrical protection or faults that cannot be detected by electrical protection.

**3.2.8.3 Voltages Used in Various Countries**

Sometimes, equipment designed to be used in certain countries is used in data centers of countries that do not use the same voltage. Most modern equipment will work within a wide range of voltages; however, some older or specialized equipment may not be as tolerant of different voltages. In these cases, a transformer is used to create the voltage needed by this equipment.

Table 3.2.8.3 shows the different medium and low voltage arrangements that are used in different countries. As an example, equipment designed for use in Japan with a voltage rating of 100V would need a special transformer to allow it to be used in other countries. These transformers are not off the shelf items, and sourcing a replacement could take a long time.

*Table 3.2.8.3. Medium and Low Voltages Used in Various Countries*

Country	Medium Voltage, kV	Low Voltage
North America	4.16 12.47 13.2 13.8 34.5	600 V 60 Hz 3 wire + ground 600/347 V 60 Hz 4 wire + ground 480/277 V 60 Hz 4 wire + ground 480 V 60 Hz 3 wire + ground 208/120 V 60 Hz 4 wire + ground 415/240 V 60 Hz 4 wire + ground
South America	6 11 13.8 22 23	220/127 V 60 Hz 4 wire + ground 380/220 V 60 Hz 4 wire + ground 400/230 V 50 Hz 4 wire + ground
Europe	10 20 35	400/230 V 50 Hz 4 wire + ground 480/277 V 60 Hz 4 wire + ground
China	10 35	380/220 V 4 wire + ground
Japan	6.6 22	200 V 3 wire + ground 200/100 V 3 wire + ground 100 V 2 wire + ground
Australia	6.6 11 33	415/240 V 50 Hz 4 wire + ground

**3.2.8.4 Heating, Ventilation, and Air Conditioning (HVAC)**

HVAC equipment is a frequent source of liquid leakage; locating it above critical equipment increases the exposure to that equipment. (This liquid leakage frequency is not intended to apply to HVAC equipment mounted on the roof).

**3.2.8.5 Power-Down of Data Processing Equipment and HVAC Systems**

3.2.8.5.1 Electrical power is an ignition source in data centers. Power that continues to be provided to consumed combustibles has the capacity to re-ignite a fire, even if flames are initially extinguished by water-based or gaseous fire protection.

Automatic de-energizing of data processing equipment removes a possible re-ignition source, improves the effectiveness of halocarbon or inert gas (clean agent) fire extinguishing systems and minimizes damage to exposed electronic circuits. It can be initiated by interfacing automatically with a smoke detection system or a water flow switch for the sprinkler or water mist system.

Power-down of the HVAC system(s) warrants the following considerations:

- HVAC power-down upon smoke detection may prevent heat and/or smoke from being drawn into data processing equipment.
- Retain the halocarbon or inert gas (clean agent) concentration when make-up air is introduced to the data processing equipment room.
- HVAC power-down upon smoke detection may cause elevated ambient temperatures within the data center. Sustained elevated temperatures may cause damage to the data processing equipment. The possible damage may vary as a function of the exposure, data processing equipment design and materials of construction.

When coordinating isolation of power to data processing equipment and HVAC equipment, consider the anticipated rate of rise for the data processing equipment room temperature if HVAC cooling is interrupted without removing power from the data processing equipment cooled by those HVAC units. Provide cooling for a sufficient time to prevent the room temperature from rising above a level that would result in damage to data processing equipment or in warranty issues (see Section 2.7.7). Coordinate the shutdown of HVAC air handlers resulting from the performance goals of these power isolation guidelines with local code requirements (e.g., duct-mounted smoke detection at HVAC air-handler inlet or outlets).

A single disconnect control integrated to de-energize and interlock both data processing equipment and HVAC systems is preferred but is a condition of the previous considerations.

For areas/rooms protected by only a halocarbon or inert gas (clean agent) fire extinguishing system, initiation of an automatic or automatic with time delay power-down of the data processing equipment sequence should occur at the alarm for discharge of the halocarbon or inert gas (clean agent) fire extinguishing system as recommended in Section 2.3.5.4. Power isolation of the HVAC will be dependent upon the system design for incoming air, which may dilute the concentration of extinguishing agent.

For areas/rooms protected by either automatic sprinkler systems or water mist systems, initiation of an automatic power isolation of the data processing equipment sequence should occur from any type of smoke detection or from the water flow alarm for the sprinkler system or water mist system as recommended in Section 2.3.5.4.

For areas/rooms protected by a halocarbon or inert gas (clean agent) fire extinguishing system or hybrid (water and inert gas) fire extinguishing system that have sprinkler or water mist protection, initiation of an automatic or automatic with time delay power-down sequence should occur at the alarm for discharge of the halocarbon or inert gas (clean agent) fire extinguishing system or hybrid (water and inert gas) fire extinguishing system as recommended in Section 2.3.5.4.

The purpose of a manual disconnect control is to preemptively initiate the de-energizing or “soft” power-down sequence of data processing equipment and/or the HVAC system separate before the automatic power-down.

### **3.2.8.5.2 Manual Disconnect Controls**

3.2.8.5.2.1 For manual disconnect controls:

- A. Group by function and/or zone the disconnect control(s) for the de-energizing and interlock of data processing equipment power and/or HVAC systems, respectively.
- B. Identify the disconnect control(s) for the de-energizing and interlock of data processing equipment power and/or HVAC systems, respectively.
- C. Use a disconnect control with a tamper-proof design.
- D. Provide signal supervision at the fire alarm control panel of electrical interlocks, and power-down devices that de-energize data processing equipment.
- E. Clearly identify which zone(s)/portion(s) of the data center each circuit breaker controls.

**3.2.8.5.2.2 Sprinklers and Water Mist Systems**

The objective of automatic sprinkler systems and water mist systems in data centers is to control a fire. It should limit fire propagation to a small area beyond the region of ignition and reduce the heat release rate to a sufficiently low level that the number of sprinklers or nozzles that activate is less than the design area to maintain sufficient pressure in the water supply. If electrical power is not interrupted as recommended, reignition of a fire from the continued delivery of electrical power is eliminated by the cooling effect of water. The power can eventually be interrupted in a controlled manner with coordination of manual fire extinguishment by the local fire service.

**3.2.8.5.2.3 Halocarbon and Inert Gas (Clean Agent) Fire Extinguishing Systems**

The objective of halocarbon or inert gas (clean agent) fire extinguishing systems in data centers is to limit the extent and severity of damage to data processing equipment and reduce the associated business interruption to a much lower level than would result from sprinkler protection alone. If a clean agent fire extinguishing system is provided, sprinklers in the same space are not expected to activate because the clean agent fire extinguishing system is activated by smoke detection that is much more sensitive than sprinklers. Clean agent fire extinguishing systems are designed to maintain an adequate concentration of agent in the protected space for only a limited period of time (typically 10 minutes). This time reflects the practical limitations of constructing rooms to be as airtight as possible, which industry experience has shown to be exponentially more difficult with longer “hold times.”

Once the extinguishing agent concentration is reduced below the required level, the fire will reignite any combustibles if the ignition source has not been removed by shutting off power to the data processing equipment of fire origin. This concentration reduction occurs after discharge either by natural seepage of the extinguishing agent through cracks in the building over a short time, or when the doors are opened to admit emergency response team or fire service personnel. Therefore, power down must be accomplished within this timeframe to prevent reignition. If a clean agent fire extinguishing system is the only fire protection installed in the space (i.e., no sprinklers) and the energized data processing equipment is not powered down, an uncontrolled fire will result with fire propagation to the limit of combustibles.

**3.2.8.6 Uptime Institute Tier Classification**

The Uptime Institute, Inc. is an independent company devoted to maximizing efficiency and uninterruptible availability in data centers and information technology organizations. The Institute has developed the Tier Classification System for rating the concurrent maintainability and fault tolerance of data center facilities (see Table 3.2.8.6)

*Table 3.2.8.6. Tier Requirements Summary*

	<i>Tier I</i>	<i>Tier II</i>	<i>Tier III</i>	<i>Tier IV</i>
Active Capacity Components to Support IT Load	N	N+1	N+1	N after any failure
Distribution Paths	1	1	1 active and 1 alternate	2 simultaneously active
Concurrently Maintainable	No	No	Yes	Yes
Fault Tolerance (single event)	No	No	No	Yes
Compartmentalization	No	No	No	Yes
Continuous Cooling (*load density dependent)	No	No	No	Yes

A Tier 1 basic data center has non-redundant capacity components and a single, non-redundant distribution path servicing the computer equipment. The site is susceptible to disruption from both planned and unplanned activities. The site infrastructure must be completely shut down to perform preventive maintenance and repair work.

A Tier II data center has redundant capacity components and a single, non-redundant distribution path serving the computer equipment. The site is susceptible to disruption from both planned and unplanned events. Redundant capacity components can be removed from service on a planned basis without causing any data processing equipment to be shut down.

A Tier III data center has redundant capacity components and multiple independent distribution paths servicing the data processing equipment. Each and every capacity component and element in the distribution paths can be removed from service on a planned basis without impacting any of the data processing equipment. Planned site infrastructure maintenance can be performed using the redundant capacity components and distribution paths to work on the remaining equipment.

A Tier IV data center has multiple, independent, physically isolated systems each having redundant capacity components and data, and independent, diverse, active distribution paths simultaneously servicing the data processing equipment. A single failure of any capacity system, capacity component, or distribution element will not impact the data processing equipment. The site infrastructure maintenance can be performed using the redundant capacity components and distribution paths to safely work on the remaining equipment.

For additional details, see the Uptime Institute's, LLC "Data Center Site Infrastructure Tier Standard: Topology", Uptime Institute Professional Services, LLC, 2012.

### 3.3 Protection

#### 3.3.1 General

##### Aerosol Generator Fire Extinguishing System Units

Aerosol generator fire extinguishing system units are not clean agent systems as defined by Data Sheet 4-9, *Halocarbon and Inert Gas (Clean Agent) Fire Extinguishing Systems*. Some products are thermally actuated, so they would not provide equipment protection in accordance with FM recommendations for this type of occupancy, even if used with sprinkler protection.

Those products that are listed by Underwriters Laboratories have specified limitations associated with the product category. In particular, they are intended for total flooding applications of normally unoccupied or uninhabitable spaces and the potential effects of aerosol extinguishing agent discharge residue on sensitive equipment and other objects have not been investigated.

##### 3.3.1.1 Portable Fire Extinguishers

Portable clean agent fire extinguishers typically in the 10-15 lb (4.5-6.8 kg) capacity, or Class "A" and Class "C" using the NFPA 10, *Standard For Portable Fire Extinguishers*, classification and rating number system, for energized electrical fires in electrical and electronic equipment in the data processing equipment and service rooms fulfill the recommendation in Section 2.4.2.

Portable carbon dioxide fire extinguishers may not be effective because the cable insulation is considered a combustible or Class "A" material. Portable carbon dioxide fire extinguishers are not rated for this hazard.

In considering whether the typical capacity of the fire extinguisher for an energized electrical fire needs to be increased or decreased, the following items should be evaluated:

- Size of the electrical equipment
- Configuration of the electrical equipment that influences distribution of the extinguishing agent
- Effective discharge range of the fire extinguisher
- Amount of combustible material involved (Class A per NFPA 10)
- Installation of a halocarbon and inert gas (clean agent) fire extinguishing system for protection of the electrical equipment

De-energizing electrical equipment eliminates the potential for an arcing hazard if the portable fire extinguisher accidentally comes into physical contact with the energized equipment or brings any conductive part within arcing distance.

A 2-1/2 gal (9.5 L) water or clean agent portable fire extinguisher (2-A rating per NFPA 10 classification and rating) for areas containing even limited amounts of ordinary combustibles is appropriate.

The travel distance of 75 ft (23 m) is based upon an ordinary (moderate) level of combustibles, such as paper and plastics. The travel distance may be decreased to improve accessibility of the portable fire extinguisher for protection of the electrical equipment.

Dry chemical extinguishers should not be used on electrical or electronic equipment and should not even be present in a data processing equipment room. The dry chemical extinguishing powder is corrosive to electronic circuitry. If such an extinguisher was discharged in an area containing electronic equipment, drifting of the very lightweight powder would likely result in the need to clean/recondition all of the equipment in the area.

### 3.3.2 Detection

3.3.2.1 Very early warning fire detection (VEWFD) systems detect smoldering or off-gassing typically generated from an overheating condition or from low-energy fires. VEWFD systems detect incipient fires in critical areas before flame or even noticeable smoke develops. VEWFD may use aspirating (air-sampling detectors) or high-sensitivity, intelligent, spot sensor/detectors. Detectors used to accomplish VEWFD are listed as being capable of providing alarm initiation at threshold levels that are more sensitive than conventional smoke detectors.

3.3.2.2 For aspirating smoke detectors and intelligent high sensitivity spot smoke detectors, typically, multiple smoke level thresholds can be used to perform a progressive response to a potential fire that minimizes business impact:

- Level 1 (Alert): Notify constantly attended location.
- Level 2 (Pre-Alarm/Action): Local alarm in protected area; initiate data transfer (re-route data to alternate data center equipment room or data center), interlock of reduced ventilation rate.
- Level 3 (Alarm/Fire): Initiate fire alarm to building fire alarm control panel and fire service, initiate suppression (or interlocked preaction sprinkler system or stage one on a double-interlock system).

Typical minimum alert and pre-alarm settings for air-sampling systems are usually 0.2%/ft (0.7%/m) obscuration (effective sensitivity at each port). Alarm settings for air-sampling systems are usually 1.0%/ft (3.3%/m) obscuration (effective sensitivity at each port).

3.3.2.3 For intelligent high-sensitivity spot smoke detectors the obscuration sensitivity levels can be programmed similar to an aspirating smoke detector. The control panel used with an intelligent high-sensitivity spot smoke detector, typically, has fewer levels of notification with a reduced progressive response.

3.3.2.4 Obscuration sensitivity levels for an air-aspirating smoke detector is programmed by software at the VEWFD control panel. Programmed obscuration levels should be verified for acceptance from submitted plans. Proprietary methods (e.g., a lap-top computer or portable handheld device with software) are available from the VEWFD manufacturer and require the installer/service person to assist in the validation. In some cases an auxiliary system monitor is used that allows the obscuration levels to be directly verified.

3.3.2.5 When evaluating the use of aspirating smoke detection versus intelligent high-sensitivity spot smoke detection, the specific requirements for the occupancy need to be considered, including the following:

- Progressive response notification
- Local identification of the event
- Type of fire protection system(s) provided
- Number of fire protection systems and/or zones provided

3.3.2.6 The location of the smoke detectors or sensors should be based on an engineering survey of the area to be protected. Factors such as air flow, proximity to air handling system diffusers, and other physical features of the installation need to be taken into account.

Smoke tests can be run to verify the air flow within the protected area favors the smoke detectors. Testing should be performed with all racks, servers, and other support equipment in full operation. In addition, it is important to have the HVAC running at normal capacity. The heat generated from the server racks and subsequent air movement from them and the HVAC will impact smoke stratification and VEWFD response and obscuration readings.

Extension of ceiling spot detectors or sensors downward into the flow path of sheared air (using photoelectric units to prevent false alarms) or providing individual addressable sampling ports to the specific server cabinet rack should be considered where strong ventilation currents cause air at the ceiling to remain relatively stagnant or identification of the event is critical.

Additional general guidance on the placement of detectors can be found in the following documents:

- Data Sheet 5-48, *Automatic Fire Detectors*
- ANSI/NFPA 72, National Fire Alarm Code
- FM Research Technical Report, *Experimental Data for Model Validation of Smoke Transport in Data Centers*

Dilution of smoke can occur within a large room and high air flow, do not exceed the recommended spacing in Section 2.4.3.

3.3.2.7 A series of tests was carried out in 1998 by one of the leading telephone companies to compare the effectiveness of various types of fire detection systems in electronic communication equipment areas. It was found that the aspirating VEWFD system detected all of the materials burned, including tests in which material was burned within the frame. The latter could not be detected by any other detector used. The projected beam detector was able to detect all fires outside of the equipment frames. The time to detection was roughly comparable to the most sensitive standard spot-type smoke detector.

The lack of one feature was considered important for standard spot-type detectors. This feature was the ability to set the detector at more than one alarm point; for example, an aspirating VEWFD detector can be set for a multiple number of pre-alarm points before the detector actually alarms. The one photoelectric standard spot detector tested alarmed in still air and under all of the air flow conditions tested for all of the materials tested. Some types of ionization spot detectors performed better than others. The ionization detectors did not detect some plastics fires. They also did not detect some fires where the air flow was from below the floor or when air flow was from ceiling-mounted diffusers to a low exit point.

3.3.2.8 Ambient temperatures in a hot aisle could be in the range of 100°F (38°C) or more, which may be the maximum or in excess of the operable temperature for the detector.

3.3.2.9 The use of a time delay is to allow for the evacuation of personnel from the protected area/room for actuation of a special protection system.

### 3.3.2.10 Portable Detection

Supplementing fixed smoke detection with portable detection is recommended to identify a localized event from the zone in which it is identified in order to provide localized power isolation and/or extinguishment. Two portable handheld devices typically used for this purpose are the aerosol monitor and the thermal imaging device. The aerosol monitor uses a light-scattering laser photometer that isolates contaminants in the optics chamber to measure concentrations that can be set to correlate to the fixed smoke detection. The handheld thermal imaging device is used to identify overheated components.

## 3.3.3 Suppression

### 3.3.3.1 Automatic Sprinkler Systems

Install wet pipe sprinklers versus pre-action sprinkler systems whenever possible. Pre-action sprinkler systems are inherently less reliable than wet sprinkler systems due to the significantly higher levels of inspection, testing, and maintenance required. Closely examine the concerns with a wet-pipe sprinkler system before installing an alternative.

Table 2.4.4.2.2 describes the introduction of water into the sprinkler piping for wet, non-interlocked, single-interlocked and double-interlocked sprinkler systems. Further detail is included in the Glossary of Terms for each sprinkler system type.

In general the lower the room ceiling height the more effective the fire protection systems will be. The limit on data center ceiling heights to 30 ft (9.1m) is intended to allow sprinkler protection to activate promptly thereby reducing fire, smoke, and water damage. The ceiling height limitation also constrains the room volume such that the halocarbon and inert gas (clean agent) fire extinguishing system sizes and halocarbon or inert gas (clean agent) distribution remain practical.



### 3.3.3.2 Water Mist Systems

3.3.3.2.1 No general design methodology exists for water mist systems. Fire control performance is not consistent between manufacturers of water mist systems. The characteristics of drop-size distribution, nozzle spacing, spray angle, installation parameters, and other characteristics are determined from full-scale fire testing to replicate a specific hazard application. Therefore, only an FM Approved water mist system listed for the specific hazard application can provide acceptable protection.

3.3.3.2.2 The performance characteristics of water mist systems will differ based upon their design principle. A water mist system could be low-pressure, single or dual fluid; or high-pressure, single or dual fluid. Do not interchange the supply pump units on different model systems, even from the same manufacturer.

3.3.3.2.3 A dual fluid system in which the compressed air or nitrogen mixed with the water was integral in evaluating the performance for fire extinguishment. Therefore, each supply pump unit needs to be used with its specific model of water mist system.

### 3.3.3.3 Halocarbon and Inert Gas (Clean Agent) Fire Extinguishing Systems

3.3.3.3.1 Even if there is no cabling below the raised floor (or no air flow), the extinguishing agent will eventually leak to the lowest point in the room, which is below the raised floor. If there is no extinguishing agent discharged in the space below the raised floor, a dilute concentration will develop in the room. That concentration may not be sufficient to provide extinguishment and may produce greater amounts of extinguishing agent decomposition. (Reference Section 2.4.4.4.5)

3.3.3.3.2 When protecting only the space below a raised floor, during and after a discharge, a portion of the extinguishing agent under the raised floor will migrate into the room above it. If any fire is present in the electrical equipment above the raised floor, the extinguishing agent would be at a level below the design extinguishing concentration. If the extinguishing agent is a halocarbon, considerable decomposition of the extinguishing agent could occur, and additional contamination may result from it. (Reference Section 2.4.4.4.5)

3.3.3.3.3 Where a second smoke detector actuation or alarm 2/second-level alarm will result in discharge of a total flooding halocarbon or inert gas (clean agent) fire extinguishing system, operating procedures should specify that all nonessential personnel evacuate the area/room. This will prevent the unfavorable situation of personnel exiting through a door after the fire extinguishing agent discharge has begun. Continuous opening of exit door(s) during or after the discharge will allow some of the extinguishing agent to escape, possibly causing the concentration in the protected area/room to drop below levels needed for fire extinguishment.

3.3.3.3.4 Always label and differentiate fire alarm pull stations and emergency power-down controls to avoid confusion.

3.3.3.3.5 When using an abort switch for halocarbon or inert gas (clean agent) fire extinguishing systems, the choice of location should consider the ability of the operator to be aware of any changes in conditions for the protected area/room.

3.3.3.3.6 Halocarbons or inert gas (clean agents) discharged from the nozzle require a certain length of distance to vaporize. If the clean agent comes in contact with a surface, e.g., cable trays, containment system walls, obstructions, before the clean agent is vaporized, frosting can occur. This will result in a delivered concentration less than the design concentration for protection of the room and/or enclosure.

3.3.3.3.7 Very short discharge times (less than 60 seconds) should not be used with inert gas fire extinguishing systems if hard disk drives are susceptible to disruption of performance by sound pressure levels (e.g. noise) from the discharge. A minimum 30-second discharge time is part of the FM Approval listing, but should be avoided for this occupancy.

## 3.4 Equipment and Processes

### 3.4.1 Mobile/Modular Data Center

Mobile/modular data centers allow for substantial economies of scale and have been designed for efficient use of energy, including considerations regarding the external environment. Fabrication techniques can be used to reduce manufacturing costs.

Modular data centers are designed for rapid deployment, and high-density computing to deliver data center capacity at a lower cost than with traditional construction methods, and to significantly reduce construction and equipment installation times.

### 3.4.2 Diagnostic Equipment

The recommendations in this data sheet are intended to supplement the recommendations in the applicable data sheet for which the diagnostic equipment is installed (e.g., hospitals, clinics, and office buildings).

## 3.5 Loss History

### 3.5.1 NFPA

A study by NFPA in 2004 concluded that properties wholly dedicated to computer or telecommunications activities are a comparatively small part of the United States fire problem. In this study, electronic equipment areas included computer areas, data processing centers, control centers, radar rooms, telephone equipment rooms, and telephone booths. The main conclusions of this survey included the following:

- A large number of fires in electronic equipment rooms do not begin with the electronic equipment or even with any equipment.
- The leading cause of fires in electronic equipment areas involves electrical distribution equipment (e.g., wiring, cables, cord, plugs, outlets, overcurrent protection devices), but not electronic equipment.
- In most cases, fire damage is limited to the object of origin.

The results of this study are consistent with FM loss experience.

## 4.0 REFERENCES

### 4.1 FM

Data Sheet 1-2, *Earthquakes*  
 Data Sheet 1-3, *High-Rise Buildings*  
 Data Sheet 1-6, *Cooling Towers*  
 Data Sheet 1-8, *Antenna Tower and Signs*  
 Data Sheet 1-12, *Ceiling and Concealed Spaces*  
 Data Sheet 1-20, *Protection Against Exterior Fire Exposure*  
 Data Sheet 1-28, *Wind Design*  
 Data Sheet 9-1, *Supervision of Property*  
 Data Sheet 9-13, *Evaluation of Flood Exposure*  
 Data Sheet 1-24, *Protection Against Liquid Damage in Light-Hazard Occupancies*  
 Data Sheet 1-40, *Flood*  
 Data Sheet 1-45, *Air Conditioning and Ventilating Systems*  
 Data Sheet 2-0, *Installation Guidelines for Automatic Sprinklers*  
 Data Sheet 2-8, *Earthquake Protection for Water-Based Fire Protection Systems*  
 Data Sheet 2-81, *Fire Protection System Inspection, Testing and Maintenance and other Fire Loss Prevention Inspections*  
 Data Sheet 3-0R, *Hydraulics of Fire Protection Systems*  
 Data Sheet 3-7, *Fire Protection Pumps*  
 Data Sheet 3-26, *Fire Protection Water Demand for Nonstorage Sprinklered Properties*  
 Data Sheet 4-2, *Water Mist Systems*  
 Data Sheet 4-9, *Halocarbon or Inert Gas (Clean Agent) Fire Extinguishing Systems*  
 Data Sheet 4-11, *Carbon Dioxide Extinguishing Systems*  
 Data Sheet 5-4, *Transformers*  
 Data Sheet 5-11, *Lightning and Surge Protection for Electrical Systems*  
 Data Sheet 5-14, *Telecommunications*  
 Data Sheet 5-19, *Switchgear and Circuit Breakers*  
 Data Sheet 5-20, *Electrical Testing*  
 Data Sheet 5-23, *Design and Protection for Emergency and Standby Power Systems*  
 Data Sheet 5-28, *DC Battery Systems*



Data Sheet 5-31, *Cables and Bus Bars*  
Data Sheet 5-40, *Fire Alarm Systems*  
Data Sheet 5-48, *Automatic Fire Detection*  
Data Sheet 7-13, *Mechanical Refrigeration*  
Data Sheet 7-110, *Industrial Control Systems*  
Data Sheet 9-0, *Asset Integrity*  
Data Sheet 9-1, *Supervision of Property*  
Data Sheet 9-16, *Burglary and Theft*  
Data Sheet 9-17, *Protection Against Arson and Other Incendiary Fires*  
Data Sheet 10-1, *Pre-Incident and Emergency Response Planning*  
Data Sheet 10-5, *Disaster Recovery Planning*  
Data Sheet 10-8, *Operators*  
Data Sheet 13-24, *Fans and Blowers*  
Data Sheet 13-26, *Internal Combustion Engines*

Thumuluru, S., Ditch, B., Chatterjee, P. and Chaos, M. *Experimental Data for Model Validation of Smoke Transport in Data Centers*. FM Research Technical Report. September 2014.

Xin, Y. and M. M. Khan. "Flammability of combustible materials in reduced oxygen environment." *Fire Safety Journal* 42 (2007) pp. 536-547.

#### 4.1.1 FM Approvals

Class Number 3972, *Test Standard for Cable Fire Propagation*  
Class Number 4882, *Class 1 Interior Wall and Ceiling Materials or Systems for Smoke Sensitive Occupancies*  
Class Number 4884, *Panels Used in Data Processing Center Hot and Cold Aisle Containment Systems*  
Class Number 4910, *Cleanroom Materials Flammability Test Protocol*  
Class Number 4924, *Approval Standard for Pipe Insulation*  
Class Number 4955, *Approval Standard for Flammability of Absorbent Battery Acid Spill Containment Pillows*  
Class Number 5420, *Approval Standard for Carbon Dioxide Extinguishing Systems*  
Class Number 5560, *Approval Standard for Water Mist Systems*  
Class Number 5580, *Approval Standard for Hybrid (Water and Inert Gas) Fire Extinguishing Systems*  
Class Number 5600, *Approval Standard for Clean Agent Fire Extinguishing Systems*

#### 4.2 Other Standards

American Society of Testing Materials (ASTM). *Standard Method of Surface Burning Characteristics of Building Materials*. ASTM E84. 2010

British Standard Institute (BSI). *Fire protection for electronic equipment installations - Code of practice*. BS 6266:2011.

British Standard Institute (BSI); European Norm. *Communication cables. Specifications for test methods. Environmental test methods. A horizontal integrated fire test method*. BS-EN-50289-4-11, 2002.

Deutsches Institut für Normung e.V. (DIN). *Testing of combustible materials; response to ignition by a small flame*. DIN 53438, 1984

Deutsches Institut für Normung e.V. (DIN). *Fire Behaviour of Building Materials and Building Components*. DIN 4102, 2009.

Institute of Electrical and Electronics Engineers (IEEE). *Recommended Practice for Powering and Grounding Sensitive Electronic Equipment*. IEEE Std 1100 1992, 1992.

Institute of Electrical and Electronics Engineers (IEEE) / American Society of Heating, Refrigerating, and Air-Conditioning Engineers (ASHRAE). *Guide for Ventilation and Thermal Management of Batteries for Stationary Applications*. IEEE 1635, 2012, ASHRAE Guideline 21, 2012.

National Fire Protection Association (NFPA). *National Electrical Code*. NFPA 70, 2011, Article 645.

National Fire Protection Association (NFPA). *Protection of Information Technology Equipment*. NFPA 75, 2024.

National Fire Protection Association (NFPA). *Fire Protection of Telecommunications Facilities*. NFPA 76, 2024.

National Fire Protection Association (NFPA). *Special Analysis Package Computer Equipment and Computer Areas*. Fire Analysis and Research Division, NFPA. 2001.

National Fire Protection Association (NFPA). *Standard Method of Test of Surface Burning Characteristics of Building Materials*. NFPA 255, (Withdrawn 2009).

National Fire Protection Association (NFPA). *Standard Method of Test for Flame Travel & Smoke of Wires and Cables for use in Air - Handling Spaces*. NFPA 262, 2023.

National Fire Protection Association (NFPA). *Clean Agent Fire Extinguishing Systems*. NFPA 2001, 2022.

Schneider Electric. *Electrical Distribution Equipment in Data Center Environments*. White Paper 61, Revision 1. Pearl Hu.

Turner, W. P., et. al. *Tier Classifications Define Site Infrastructure Performance*. Uptime Institute. 2008.

Underwriters Laboratories (UL). *Tests for Flammability of Plastic Materials for Parts in Devices and Applications*. UL 94, 2023.

Underwriters Laboratories (UL). *Test for Surface Burning Characteristics of Building Materials*. UL 723, 2023.

Underwriters Laboratories (UL). *Test Performance of Air Filter Units*. UL 900, 2022.

Underwriters Laboratories (UL). *UL Standard for Safety for Flame-Propagation and Smoke-Density Values for Electrical and Optical-Fiber Cables used in Spaces Transporting Environmental Air*. UL 910 (Withdrawn 2001).

Underwriters Laboratories (UL). *Test Methods for Determining the Combustibility of Characteristics of Plastics Used in Semi-Conductor Tool Construction*. UL 2360, 2023.

Underwriters Laboratories (UL). *Information Technology Equipment - Safety - Part 1: General Requirements*. UL 60950-1, 2019.

Underwriters Laboratories (UL). *Information Technology Equipment - Safety - Part 21: Remote Power Feeding*. UL 60950-21, 2022.

## APPENDIX A GLOSSARY OF TERMS

**Aisle:** The distance of floor across from two rows of server racks or cabinets, typically 4 ft (1.2 m). See also cold aisle, hot aisle and hot/cold aisle containment.

**Automated tape library (ATL):** An enclosed storage and retrieval system that moves recorded electronic data (e.g., plastic cassettes) between storage and server equipment.

**Air-aspirating detection:** See "Very early warning fire detection (VEWFD)."

**Availability:** The degree to which a system, subsystem or equipment is in a operable state when it is requested for use at any random time.

**Battery Back-up Unit (BBU):** Batteries housed inside a metal enclosure with a cross-sectional area of approximately 4 sq. in (25 sq. cm). The individual battery unit is typically the length as the server. The module is used for DC power backup and typically hot-swappable (i.e., it can be replaced without interruption to the power circuit) in the server rack. The battery module may or may not contain a Battery Management Systems (BMS).

**Business continuity:** A strategic approach to business as a whole, involving the development of a response to safeguard the entire business by managing the impact of a disruption to achieve the company's business objectives for survival, regardless of the cause of the disruption. By implication, the development of the BCP requires a much deeper understanding of the business, the criteria for business survival, the continuity strategies available, and the resources necessary to implement the continuity response.

**Building automation system:** A centralized building automatic control system, usually controlling at least the HVAC but that may also control lighting, security, safety, electric power, fire alarm, or any other building system. Also known as a building management system (BMS).

**Cabinet:** Device for holding data center equipment, most commonly used to hold multiple servers. Also called a rack.

**Cold aisle:** The aisle in front of the airflow intakes on the server racks where HVAC cooling airflow is controlled.

**Co-location:** Rental to third parties of disk space, provision of web-hosting services on a server, or segmented areas with individual tenants that control their own equipment.

**Cloud computing:** A model for enabling convenient, on-demand network access to a shared pool of configurable computing resources (e.g., networks, servers, storage, applications, and services) that can be rapidly provisioned and released with minimal management effort or service provider interaction.

**Computer room air conditioner (CRAC):** An air handler that uses refrigerant and an internal compressor dedicated to providing cooling air to the data processing equipment space. Cooling the air in the data processing equipment room is accomplished by airflow over evaporation cooling coils where the refrigerant is being directly expanded.

**Computer room air handler (CRAH):** An air handler dedicated to providing cooling air to the data processing equipment space that uses chilled water cooling coils within the unit. Central cooling equipment (e.g., chiller) is located in separate mechanical rooms.

**Data center:** A facility used to house data processing equipment and associated components, such as telecommunications and storage systems. It generally includes redundant or backup power supplies, redundant data communications connections, environmental controls (e.g., HVAC, fire suppression) and security devices.

**Data processing equipment room:** A room mostly occupied with data processing equipment such as servers, tape cartridge storage, printers, etc.

**Disaster recovery:** Activities necessary to respond to an incident at a location to restore normal operations after a major disaster or specific scenario. DRPs are therefore written to establish the necessary actions to take during and immediately after an anticipated event to expedite the resumption of normal operations.

**Disconnect control:** A device that controls the interface of the disconnecting means of power by a pathway, relay, or equivalent method.

**Double-interlock preaction system:** A sprinkler system that is located downstream of a preaction valve and is equipped with closed-type sprinklers. The preaction valve is arranged to open only after the actuation of both a sprinkler and a detection system that is supervising the area being protected by the preaction sprinkler system. Most double-interlock sprinkler systems have either an electric or a pneumatic means of accomplishing these two activating conditions.

**Emergency Power Off (EPO):** See Manual Disconnect Control.

**High-rise building:** Any building with an occupied floor located more than 75 ft (23 m) above the lowest level of fire service vehicle access with the exception of:

- Airport traffic control towers
- Open parking garages
- Amusement park structures
- Bleachers
- Grandstands
- Stadiums
- Special industrial buildings (ex. BLRB)
- Buildings with high hazard occupancies

**Hot aisle:** The aisle at the rear of the server racks into which air is directed after being heated by passing through the data processing equipment for return to the HVAC equipment.

**Hot/cold aisle containment:** Physical barriers provided in the immediate vicinity of air-cooled server racks that separate hot air exhausted from the data processing equipment from the cooler supply air into the equipment racks. Containment is typically provided above and at both ends of a hot or cold aisle, in whole or in part.

**Hot air collar:** An assembly used to duct heated exhaust air from an enclosure(s), cabinet(s), or rack(s) of the data processing equipment to the return air path of the HVAC system.

**Input/output (I/O) room:** The room where the electronic hardware is wired to interface from the control room with the field/process devices. Discrete I/O devices have switches for inputs and relay outputs (e.g., operate solenoid valves or pump motors). Analog I/O devices have process variable inputs, and variable controller outputs.

**Intelligent high-sensitivity spot detection:** See “Very early warning fire detection (VEWFD).”

**Listed:** Listed by a reputable testing laboratory according to a widely recognized testing standard adopted by model building codes.

**Manual disconnect control:** A means to preemptively initiate the de-energizing or “soft” power-down sequence of data processing equipment and/or the HVAC system.

**Mobile/modular data center:** An enclosed construction unit or prefabricated container (e.g., ISO shipping container) containing data processing equipment (e.g., servers, storage, networking, software management) and/or supporting utility systems (e.g. power, power conditioning, HVAC) intended to be configured on a modular basis either as a standalone unit or several units combined in an array to provide data center functions.

**N+1:** Need plus one, a redundancy concept where operational capacity is met by one or more components or systems, plus one additional component or system adequate to enable continued operations in the event of a failure of one component or system in the base configuration.

**Network Control room:** A room serving as an operations center where a facility, service, or equipment can be remotely monitored by electronic equipment and controlled by personnel. The network control room is used in network, command and control, and other control application operations.

**Network/fiber optic room:** A space that supports cabling to areas outside the data processing equipment room. The network/fiber room is normally located outside the data processing equipment room but, if necessary, can be combined with a main distribution area, intermediate distribution area or horizontal distribution area. The network/fiber room may also be referenced as the telecommunications room.

**Non-interlock preaction system:** A sprinkler system that is located downstream of a preaction valve and is equipped with closed-type sprinklers. The preaction valve is arranged to open upon either the operation of a sprinkler or the actuation of a detection system that is supervising the area being protected by the preaction sprinkler system.

**Nonpropagating or Group 1 cable:**

1. Cable with a fire propagation index (FPI) of less than 10 when tested in the FM fire propagation apparatus.
2. Cable that, when tested in accordance with the FM 3972 Vertical Tray Test, does not have flame spread more than 5 ft (1.5 m) beyond the 60 kW fire exposure.
3. Cable that has passed UL 910 or NFPA 262 tests.

**Plenum-rated cable:** Considered non-fire propagating and equivalent to FM Approved Group 1 cable.

**Preaction sprinkler system:** A sprinkler system that is located downstream of a preaction valve and is equipped with closed-type sprinklers (i.e., sprinklers equipped with a thermal sensing element and an orifice cap).

**Preaction valve:** An automatic water control valve, typically installed on a sprinkler system riser, specifically designed to hold back water from passing through it until certain conditions have been met, such as activation of a detection system supervising the area protected by the preaction sprinkler system or by pressure drop downstream of the valve. It is connected upstream of a preaction sprinkler system.

**Process control room:** A cutoff and/or isolated room in which personnel are available 24/7 to operate a process from a central or remote location. The process control room is typically integrated with an input/output room and/or cable spreading room to control the function of equipment. Process control is extensively used in industry and commonly enables mass production of continuous processes such as, paper, pharmaceuticals, chemicals, and electric power as well as other industrial processes, such as supervisory control and data acquisition (SCADA) systems. Process control rooms/technical spaces may be unattended and operated remotely.

**Propagating cable:**

1. Cable with a fire propagation index (FPI) of more than 10 when tested in the FM fire propagation apparatus.
2. Cable that, when tested in accordance with the FM 3972 Vertical Tray Test, has a flame spread greater than 5 ft (1.5 m) beyond the 60 kW fire exposure.
3. Cable that has not been tested or has not passed UL 910 or NFPA 262 tests.

**Proportional-integral-derivative (PID) controller:** A control loop feedback mechanism controller commonly used in industrial control systems. A PID controller continuously calculates an error value as the difference between a desired setpoint and a measured process variable and applies a correction based on proportional, integral, and derivative terms, (sometimes denoted P, I, and D respectively) which give their name to the controller type.

**Quantum Computer:** A quantum computer is a machine that uses the properties of quantum physics to store data and perform computations. The basic unit of memory is a quantum bit or qubit. Qubits are made using physical systems, such as the spin of an electron or the orientation of a photon. Qubits can represent numerous combinations of binary bits (1 and 0) simultaneously at the same time for potential outcomes.

**Raceway:** An enclosed channel of metal or nonmetallic materials designed for holding wires, cables or bus bars.

**Rack:** Device for holding data center equipment, most commonly used to hold multiple servers. Also called a cabinet.

**Routing assembly:** A single channel or connected multiple channels, as well as associated fittings, forming a structure system that is used to support, route, and protect wires and cables.

**Row:** A group of server racks or cabinets contiguously joined together.

**Server:** Data processing equipment that serves information to computers that connect to it. When users connect to a server, they can access programs, files, and other information from the server. Common servers are web servers, mail servers, and LAN servers.

**Server farm:** A collection of computer servers usually maintained by an enterprise to accomplish server needs far beyond the capability of one machine. Server farms often have backup servers that can take over the function of primary servers in the event of a primary server failure. Server farms are typically co-located with the network switches and/or routers that enable communication between the different parts of the cluster and the users of the cluster. The computers, routers, power supplies, and related electronics are typically mounted on racks in a server room or data center.

**Shelter-in-place:** A building space designed and constructed to provide protection to occupants in a natural or other disaster. The space may be structurally reinforced to resist the highest forces anticipated (e.g. wind, impact, blast pressure, heat, etc.) and will provide breathable air for the expected duration of the emergency.

**Single-interlock preaction system:** A sprinkler system that is located downstream of a preaction valve and is equipped with closed-type sprinklers. The preaction valve is arranged to open upon the actuation of a detection system that is supervising the area being protected by the preaction sprinkler system.

**Soft power-down:** A disconnect control that triggers a sequence of data processing equipment commands followed by de-energizing such that an orderly power-down is necessary to minimize data processing equipment damage.

**Tape library:** In data storage, a tape library is a collection of magnetic tape cartridges and tape drives. An automated tape library is a hardware device that contains multiple tape drives for reading and writing data, access ports for entering and removing tapes and a robotic device for mounting and dismounting the tape cartridges without human intervention.

**Thermal runaway:** Rapid heating of data processing equipment above critical operating temperatures, which may cause short-term data processing equipment damage due to loss of cooling to the data processing equipment space. Possible causes include loss of power to portions of or the entire facility, loss of power to critical HVAC cooling components, and failure of individual HVAC components.

**Unoccupiable enclosure or space:** An enclosure or space that has dimensions and physical characteristics such that it cannot be entered by a person.



**Valve-regulated lead acid batteries (VRLA):** Batteries designed to minimize gas emissions and eliminate electrolyte maintenance by recombination of internally generated oxygen and hydrogen to conserve water. A resealable valve is intended to vent gases not recombined, hence the term “valve-regulated.” The electrolyte in a VRLA cell is “immobilized” by the use of a highly porous fibrous mat between the plates or by the use of a gelling agent to thicken the electrolyte.

**Very early warning fire detection (VEWFD):** These detectors maybe photo-electric spot-type or air-sampling type detection systems. Spot detectors using xenon or laser light detection chambers can be considered VEWFD detectors. VEWFD detectors are an order of magnitude more sensitive than conventional smoke detectors. These detectors can be set to alert at smoke obscuration levels below 0.02 percent per foot (0.06 percent per meter) and an alarm condition at a smoke obscuration level below 1.0 percent per foot (3.1 percent per meter). Conventional smoke detectors alarm at 1 to 3 percent per foot (3.3 to 9.8 percent per meter).

**Water Delivery Delay:** The time in which water travels from the opening of a preaction system alarm check valve to the most remote sprinkler or inspector’s test connection.

**Zone:** A distinct area, created by a physical barrier or division of open space, from the total area of a data processing equipment room that is segmented into dedicated power and/or HVAC systems for the data processing equipment.

## APPENDIX B DOCUMENT REVISION HISTORY

The purpose of this appendix is to capture the changes that were made to this document each time it was published. Please note that section numbers refer specifically to those in the version published on the date shown (i.e., the section numbers are not always the same from version to version).

**October 2024.** Interim revision. The following changes were made:

- A. Modified the current recommendations to identify data centers should not use polyvinyl chloride (PVC) construction materials (Section 2.2.1).
- B. Added new Appendix E, *Testing of Power Isolation Disconnect Control Systems*, which provides an overview of the integrated system with by-pass that allows for testing the depowering of electrical equipment in the data processing equipment room.

**January 2024.** Interim revision. The following changes were made:

- A. Modified the scope of Operating Standard 5-32 to identify the exclusion of industrial control instrumentation equipment rooms. Those property loss prevention recommendations are covered in Data Sheet 7-110, *Industrial Control Systems*.
- B. Simplified the current protection recommendations for the various hazards in a data processing equipment room to a standard protection criterion.
- C. Formatted Section 2.0, Loss Prevention Recommendations to realign active and passive protection of equipment and processes used in a data center to the different hazard areas within the occupancy.
- D. Revised Hot and Cold Aisle Containment figures to identify sprinkler and nozzle locations.
- E. Added the following terms to Appendix A, Glossary of Terms:
  - Aisle
  - Cabinet
  - Row
  - Water Delivery Delay

**July 2023.** Interim Revision. Made editorial change to Table D-2 of Class C design concentration for FK-5-1-12. Revised the minimum design concentration percentage to include the proper safety factor based upon the Class A minimum extinguishment concentration.

**January 2023.** Interim revision. The following changes were made:

- A. Updated recommendations in Section 2.4.4 to allow equipment using Li-ion batteries in distributed power systems of data processing equipment to be protected with automatic water mist systems.

B. Made editorial updates to figures in Section 2.8.1, Electrical Distribution System and Section 3.4.1, Electrical Power Distribution.

**July 2022.** Interim revision. The following significant changes were made:

A. Added recommendations for the protection of equipment using Li-ion batteries in the following:

1. Battery back-up units for distributed power systems of data processing equipment
2. Uninterruptable power supplies (UPS) (refer to Data Sheet 5-28, *DC Power Systems*)
3. Energy storage systems (reference to Data Sheet 5-33, *Lithium-Ion Battery Energy Storage Systems*)

B. Modified guidance in Section 2.2, Construction and Location:

1. For multi-story data centers to be in accordance with specific sections of Data Sheet 1-3, *High Rise Buildings*
2. To address leakage of liquids (Section 2.2.1.6) in accordance with Data Sheet 1-24, *Protection Against Liquid Damage*
3. To provide preventing unauthorized access to a data center in accordance with Data Sheet 9-1, *Supervision of Property*

C. Added recommendations to address the impact high velocity and horizontal airflow for the cooling of data processing equipment has on the actuation and operation of sprinklers, water mist system nozzles, and smoke detection (Section 2.4.3).

D. Updated guidance on the proper application of wet, single, and double interlock sprinkler and water mist system configurations (Sections 2.4.7.1 and 2.4.7.2, respectively).

E. Updated recommendation and support guidance for oxygen reduction systems (Sections 2.4.1.7 and 3.2.1B) to conform with Data Sheet 4-13, *Oxygen Reduction Systems*.

F. Updated recommendations in Section 2.4.7.3.7 for the proper placement of FM Approved clean agent fire extinguishing system discharge nozzles based on the listing to provide sound pressure level values to hard disk drives that are susceptible to damage.

G. Updated guidance in Section 2.5.2, Hot/Cold Containment and Hot Collar Systems, to address inclusion of FM Approved panels to the FM Approval Class 4884 Standard.

H. Added general guidance for "Quantum" computers in equipment and processes (Sections 2.5.1 and 3.3.1, respectively).

I. Added guidance for B&M equipment with the specialized recommendations for their application in data centers and related facilities (Section 2.8, Utilities and Support Systems).

J. Updated recommendations for automatic power isolation in Section 2.8.2, Power Isolation of Data Processing Equipment and HVAC Systems.

**October 2021.** Interim revision. Removed the recommendation on battery design, installation, inspection, testing, and maintenance in this document. Replaced recommendations with reference to Data Sheet 5-28, *DC Battery Systems*.

**July 2020.** Interim revision. Added equipment contingency planning and service interruption planning guidance.

**April 2020.** Interim Revision. Clarifications were made in the following section:

1. A new general recommendation (Section 2.4.5) for local alarms to be annunciated at a constantly attended location to be consistent with recommendations to allow for implementation of a Power Isolation Plan.

**October 2019.** Interim Revision. The following changes were made:

A. Transferred Recommendations associated with process control rooms to OS/DS 7-110, Industrial Control Systems.

**January 2018.** Interim revision. The following changes were made:

A. Added alternative method to anchoring of equipment for securement to earthquake.



**April 2017.** The following changes were made:

1. Revised the scope of this data sheet to identify when recommendations apply to telecommunication facilities using Voice over Internet Protocol (VoIP) equipment and other related occupancies that have data processing equipment rooms/halls.
2. Added new recommendations to Section 2.2.1, General, for the proper location of HVAC equipment in data processing equipment rooms.
3. Revised recommendations in Section 2.2.10, Earthquake, to align with the recommendations in Data Sheet 1-2, *Earthquakes*.
4. Revised recommendations in Section 2.2.12, Flood/Storm Water Runoff, to align with the recommendations in Data Sheet 1-40, *Flood*.
5. Revised the recommendation in Section 2.3, Occupancy, as follows:
  - a. Removed the allowance of two pallet loads of in-process storage in the data processing equipment room based on the 2014 Engineering Support Project.
  - b. Added recommendation for storage to be in accordance with Data Sheet 8-9, *Storage of Class 1,2,3,4 and Plastic Commodities*.
6. Added recommendation in Section 2.4.5.7 for the use of portable smoke detection.
7. Revised recommendations in Section 2.4.6.1, Automatic Sprinklers, to include the following based on the 2014 Engineering Support Project:
  - a. Removed recommendation for double-interlocked sprinklers.
  - b. Added recommendation for minimum pressure of sprinklers protecting elevated hazards.
8. Revised recommendations in Section 2.4.6.2, Water Mist Systems, based on the 2014 Risk Service Project.
9. Added new recommendations to Section 2.4.6.3, Clean Agent Fire Extinguishing Systems, to address the impact of noise (from discharge) on hard drives.
10. Revised the recommendation in Section 2.5.1.1, Equipment, on blanking plate materials of construction.
11. Added new recommendation to Section 2.5.2.2 on materials that can be used for solid ceilings in hot/cold aisle containment systems.
12. Revised the recommendations in Section 2.5.2.4, Sprinkler Protection for Hot/Cold Aisle Protection, based on the 2014 Engineering Support Project.
13. Added Section 2.7.2 Power Isolation Plan.
14. Revised the recommendations in Section 2.7.5, Security, to align with Data Sheet 9-1, *Supervision of Property*.
15. Added Section 2.7.7 Loss of Cooling Emergency Response Plan.
16. Revised Section 2.8.2, Power-Down of Data Processing Equipment and HVAC Systems. Changed terminology from "power-down" to "power isolation."
17. Added new recommendations to Section 2.8.5, Heating, Ventilation, and Air Conditioning Systems, to address loss of cooling.
18. Added information to Section 3.1.3, Cables, to support the recommendation of not using power cables with chlorinated polyethylene or polyvinyl chloride (PVC) sheathing or insulation.
19. Added information to Section 3.2.4.10, Portable Detection, to support the recommendation for the usage of portable smoke detection.
20. Added new information to Section 3.2.5.3.7 regarding clean agent fire extinguishing systems to address the impact of noise (from discharge) on hard drives.

21. Revised Section 3.4.1, Electrical Power Distribution, to provide more information on the types of power supplies used in data centers.

22. Added Section 3.4.2, Electrical Protection for the Data Center, to provide more information on the types of passive protection used for power supplies in data centers.

23. Revised Section 3.4.4, Power-Down of Data Processing Equipment and HVAC Systems. Changed terminology from “power-down” to “power isolation.”

24. Added the following terms to Appendix A, Glossary of Terms:

- Availability
- Building automation system
- Computer room air conditioner (CRAC)
- Computer Room air handler (CRAH)
- Listed
- Network/fiber optic room
- Proportionalintegralderivate (PID) controller
- Thermal runaway

25. Made editorial changes throughout the data sheet to clarify the intent of the recommendations.

**July 2012.** This data sheet has been completely rewritten. Major changes include the following:

1. Changed the title from *Electronic Data Processing Systems* to *Data Centers and Related Facilities*.
2. Added hot/cold aisle containment systems and protection recommendations.
3. Added the recommendation for the protection of foam insulation beneath raised floors in the data processing equipment room.
4. Added guidance on using clean agent fire extinguishing systems and water mist systems.
5. Added protection recommendations for modular data centers.
- 6.

Added protection recommendations for process control rooms, control rooms, and diagnostic equipment. Recommendations in the specific sections for process control rooms, control rooms, and diagnostic equipment when identified will supersede those for data centers.

7. Added recommendations for redundancy of certain critical utility systems: heating, ventilation and air conditioning (HVAC) systems, chillers, and ventilation.

8. Updated the section on automatic power-down to include powering down and de-energizing data processing equipment and HVAC systems.

9. Deleted the recommendation for automatic smoke control and removal systems.

**May 2005.** The revisions are based on a change in Data Sheet 5-31, *Cables and Bus Bars*. The change combines FM Approved Group 2 and Group 3 cable along with cables that have not been tested by FM and considers these as cables that can “propagate” fire. “Nonpropagating” cable does not require protection. Nonpropagating cable is either (a) FM Approved Group 1, (b) UL-910 plenum rated or (c) cable with a maximum flame spread distance of 5 ft (1.5 m) when tested in accordance with NFPA 262, *Standard Method of Test for Flame Travel and Smoke of Wires and Cables for use in Air Handling Spaces*.

**January 2005.** Reference to the future use of Halon 1301 and 1211 systems for protection of computer and computer related equipment has been replaced with a recommendation for the use of clean agent systems installed in accordance with Data Sheet 4-9, *Clean Agent Fire Extinguishing Systems*.

**September 2004.** Recommendation 2.4.2.1.2 was modified to allow the use of light hazard water mist systems FM Approved for open area protection.

**September 2002.** Recommendation for protection of subfloor areas of the computer room has been revised to include the use of FM Approved Clean Agent fire extinguishing systems and water mist systems.

**January 2001.** The document has been reorganized to provide a consistent format.

**September 2000.** The document has been reorganized to provide a consistent format.

**May 1999.** The recommendation for grounding of computer systems was revised. Also, guidance for fire protection of Group 2 cables that are randomly laid (unbundled across the floor) was modified.

**June 1993.** Data Sheet 5-32 has been completely rewritten.

### APPENDIX C PERFORMANCE TEST PROCEDURES FOR VEWFDF SYSTEMS

Performance tests for VEWFDF systems are intended to simulate the small amounts of smoke that would be created in the early stages of a fire in a data processing equipment room. If an actual fire were to produce the amounts of smoke produced by these tests, data center companies would want to be alerted by the fire alarm system. The tests represent a good balance between the desire to use smoke sources that are representative of the types of fires that have occurred in data processing equipment rooms and the desire to minimize the introduction of smoke that can cause damage to operating data processing equipment in the area/room.

#### C.1. Objectives

Performance tests are intended to meet the general objectives listed below:

- A. The tests are intended to be repeatable. A consistent quantity, temperature, and color of smoke are produced each time the test is performed.
- B. The test equipment can be quickly set up in actual data center facilities.
- C. Testing is intended to prevent or minimize the potential for smoke damage to data processing equipment in the room (little or no corrosive products of combustion should be produced).

#### C.2. Heated Wire Test

This test uses an electrically overloaded PVC-coated wire to simulate the early stages of a fire. Although a PVC wire is used, hydrogen chloride vapor is unlikely to be produced in quantities significant enough to be of concern, due to the relatively low temperatures reached. If the current is applied for a longer time, or if the wire sample is shorter than stated, small quantities of hydrogen chloride can be generated. In either event, a clearly perceptible odor that should dissipate in a short time is produced by the test. Table C2 describes two heated wire tests.

Table C-2. Heated-Wire Test Parameters

Parameter	Modified BS 6266 Test: 1 m Wires in Parallel	North American Wire Test
Wire Specs	Wire is very flexible due to stranded construction and highly plasticized insulation.	A single strand of 22 AWG copper wire, insulated with PVC to a radial thickness of 1.1 mm (0.041 in.). This wire is stiffer than the BSI wire due to the single-strand construction and the minimally plasticized PVC insulation.
Smoke Characterization	More visible smoke than the 2 m test or the single wire 1 m test but still very light smoke. Due to the higher temperature in the wires, a small amount of HCl vapor will be produced.	More visible smoke than the BSI wire tests but still very light. A minor amount of HCl is produced but for a shorter duration than the BSI wires tests.
Test Period	60 seconds	30 seconds
Electrical Load	Constant voltage -6.0 volts dc, current varies from 0 to 30 amperes during the test due to changing resistance in the wire.	Constant current of 28 amperes. Voltage varies from 0 to 18 volts dc during test due to changing resistance in the wire.
Pass/Fail Criteria	"Alert" or "pre-alarm" signal within 120 seconds of the end of the period.	

#### A. Test Apparatus

The test apparatus consists of the following:

1. Wire. Table C-2 lists options for wire selection and test parameters for the users to select. Test wire should be cut cleanly to the length specified in Table C-2.
2. Wire Mounting. The wire should be arranged by placing it on a noncombustible, nonconductive board, or suspending it on a noncombustible, nonconductive support. The wire should be arranged so that there are no kinks or crossovers where localized higher temperature heating can occur.
3. Power Supply and Leads. A regulated dc power supply should be capable of supplying a current of 0 to 30 amperes at 0 to 18 volts dc (i.e., Kenwood Model XL6524E-D). The lead wires between the power supply and the test wire (s) should be 10AWG, 3.25 m (10.66 ft) long to avoid unacceptable voltage drop.
4. Stop Watch. A stop watch or clock accurate to 1 second should be used.

#### B. Test Procedure

1. The test should be performed in the room in which the detection system is installed, with all normal ventilation fans (e.g., fans internal to equipment, room ventilation fans) operating. Testing should also be performed with the fans turned off to simulate the potential for fan cycling and/or a power failure. This does not preclude testing required by NFPA 72.
2. Detector Programming. The detector alarm sensitivity setting (i.e., pre-alarm or alarm) used during the test should be identical to those used during normal operation of the detection system. Alarm verification or time delay features should be disabled during the test to permit the detector response to be annunciated immediately upon activation.

This testing is intended to verify that the detectors or sensor will "see" smoke in sufficient concentrations to reach the specified alarm levels.

Because the test produces a small amount of smoke for a brief period of time (i.e., a puff of smoke), the use of the alarm verification or time delay features would likely result in the detector or sensor not reaching the specified alarm levels. In a "real world" fire, the smoke would continue to be produced as the fire grows, permitting the detector or sensor to reach alarm. If these features are disabled during the testing, they should be enabled at the conclusion of the testing before leaving the room.

3. Test Locations. Test locations should be selected by considering the airflow patterns in the room and choosing challenging locations for the tests (i.e., both low airflow and high airflow can be challenging). If possible, the locations and elevations of the test apparatus should be varied to simulate the range of possible fire locations in the room. Locations where the smoke will be drawn directly into the data processing equipment cooling ports or fans should be avoided. Locations where the smoke will be entrained into the air exhausting from an equipment cabinet are acceptable.
4. Preparation. The test wire should be prepared by carefully removing not more than 0.6 in. (12 mm) of the insulation from each end. The wire should be mounted on the insulating material so that there are no kinks or crossovers in the wire.
5. Setting. The power supply should be set to supply either a constant voltage or constant current as shown in Table C-2.
6. Connection. The ends of the test wire(s) should be connected to the power supply leads.
7. Test. When all other preparations are complete, the power supply should be switched on for a period shown in Table C-2. After the appropriate current application time, the power supply should be turned off, and the test results should be observed and recorded. To avoid burns, the wire should not be touched during the test, or for 3 minutes after turning the power supply off. If the wire is located close to HVAC registers or equipment exhaust ports, the airflow can cool the wire and result in inadequate production of smoke. In this event, either the apparatus should be repositioned or the wire should be shielded from the airflow.
8. Test Sequence. The test should be repeated at least three times for each HVAC condition, with the test apparatus placed in a different location in the room each time. If possible, the elevation of the test apparatus should be varied.
9. Pass/Fail Criteria. The pass or fail criteria for the VEWFD system should be as indicated in Table C-2.

## APPENDIX D CLEAN AGENTS

Clean agents listed in Tables D-1 and D-2 are typically used for electronic equipment applications. The concentrations given for ordinary combustibles (Class A) and ignitable liquids (Class B) are accepted by NFPA 2001 based on their listing with the system manufacturer. The ignitable liquids (Class B) concentrations are provided as a comparative reference to the other hazard concentrations.

For cables that could be de-energized, the design concentration required for an ordinary combustible (Class A) would be used. Although electronic data processing equipment cannot be expected to be de-energized quickly based upon certain risk factors. NFPA 2001 has recognized that a higher agent concentration should be used for low energy faults (480 volts) by adding a safety factor of 1.35, determined by consensus, to the ordinary combustible (Class A) extinguishing concentration.

FM Research has conducted testing that indicates still higher concentrations are needed for higher energy arcing faults. This is due to the effect of the type of fault and power level (energy augmented combustion) has on the ability to attenuate the energized source. However, it is an indication that higher design concentrations for energized electrical equipment are expected and a function of the power level.

If the fault is not de-energized before clean agent concentration is dissipated, re-ignition is expected. These higher concentrations need to be reviewed for restrictions when used in normally occupied areas.

Table D-1. Design Concentrations for Clean Agents

Extinguishing Agent	Minimum Class A Design Concentration from Manual, percent <sup>(Note 1)</sup>	Minimum Class B Design Concentration from manual, percent <sup>(Note 2)</sup>
FK-5-1-12 (NOVEC 1230)	4.2	5.8
HFC-125 (FE-25)	8.0	11.0
HFC-227ea (FM-200/FE-227) <sup>(Note 3)</sup>	6.25, 7.0	8.7, 9.0
IG-541 (INERGEN)	34.2	40.6
IG-55 (Argonite, ProInert)	37.9	39.1

Note 1. The minimum design concentration for ordinary combustible materials (Class A) can be used for an electrical ignition (Class C) source with de-energizing of the source upon clean agent fire extinguishing system actuation.

Note 2. Ignitable liquids (Class B) design concentrations are based upon heptane as the fuel.

Note 3. The lower design concentration of the two is the result of a retest by the manufacturer. Refer to the *Approval Guide* listing for the appropriate concentration.

Table D-2. Design Concentrations for Clean Agents with an Energized Electrical Hazard

Extinguishing Agent	Energized Class C, percent $\leq 480V$ <sup>(Note 1)</sup>	Energized Class C, Percent $> 480V$ <sup>(Note 2)</sup>
FK-5-1-12(NOVEC 1230)	4.7	10
HFC-125 (FE-25)	9.0	20
HFC-227ea(FM-200/FE-227)	7.0, 7.8	12
IG-541 (INERGEN)	38.5	57
IG-55 (Argonite, ProInert)	42.7	Not Tested

Note 1. Refer to the *Approval Guide* listing for the appropriate concentration.

Note 2. FM conducted testing that indicates higher agent concentrations are needed for high-energy arcing faults. Only certain clean agents were tested. Refer to Section 3.3 for additional information on this testing. Where an agent is listed as "not tested," additional testing is necessary if the clean agent system is intended to protect energized electrical hazards greater than 480 volts that remain energized following discharge. Do not use an agent to protect high-energy electrical hazards if this testing has not been conducted.

These higher concentrations in Table D-2 need to be reviewed for restrictions when used in normally occupied areas. See Section 3.4 and Table 5 of Data Sheet 4-9, *Halocarbon and Inert Gas (Clean Agent) Fire Extinguishing Systems*, for information regarding No Observed Adverse Effects Limit (NOAEL) and Lowest Observed Adverse Effects Limit (LOAEL).

**APPENDIX E TESTING OF POWER ISOLATION DISCONNECT CONTROL SYSTEMS**

**Power Isolation Disconnect Control Systems** A key process of data processing equipment rooms is power isolation and the ability to test this function. Simply put, upon command as triggered by a manual disconnect control (e.g. Emergency Power Off [EPO] button), fire/smoke event or another emergency situation, the power isolation disconnect control system de-energizes equipment in the impacted area either automatically or manually.

**Purpose and Function of the Power Isolation Disconnect Control System is as follows:**

- Remove as much electricity as possible from impacted area to minimize the risk of electrocution to emergency personnel as they arrive on site.
- Depowering HVAC systems in a fire event may help reduce the propagation of fire from combustible materials.
- Isolating the power from critical loads prior to water (sprinkler and water mist systems) flow may maintain the operability of this equipment, thus saving the cost of replacement.

**Power Isolation Disconnect Control System design must take into account:**

- All critical spaces, power sources, electrical distribution, back-up and cooling equipment.
- Incorporate all input triggers, such as manual disconnect controls, e.g. EPO buttons, at egress doors and Fire Alarm calls.
- Ensure capability of testing the power isolation disconnect control system on a regular basis. To accomplish this objective, a power isolation disconnect control panel (reference Darwell Integrated Technology Inc, TripMaster EPO Control) is typically required.
- Provide appropriate training for all personnel associated with the critical spaces.

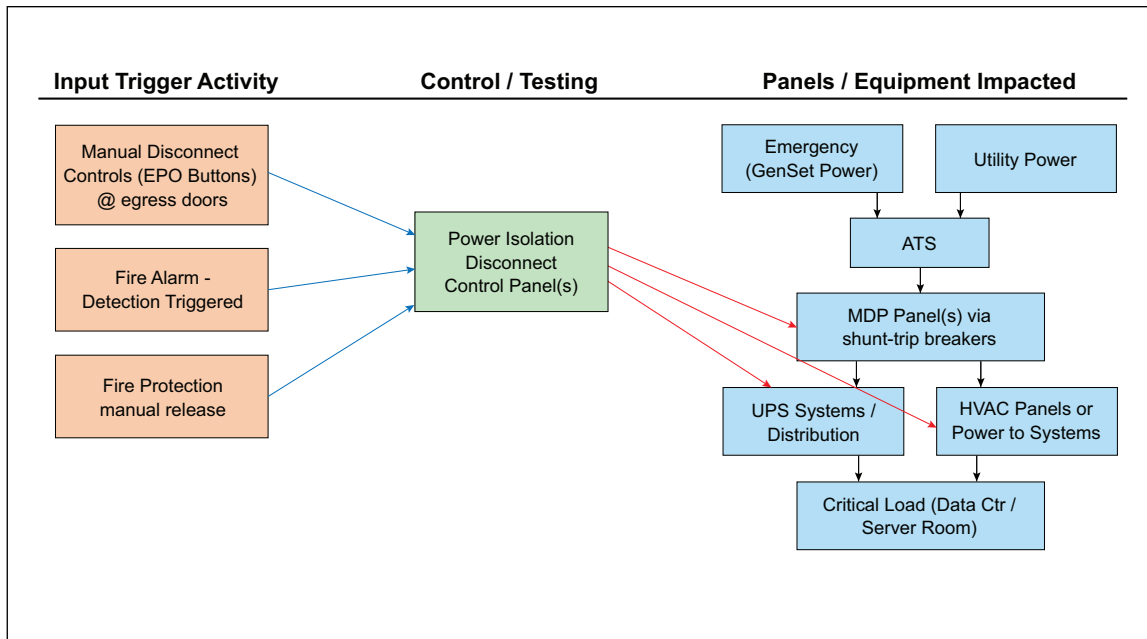

Fig. E-1. Basic power isolation disconnect control system framework

**Notes:**

1. Input triggers will vary based on the data processing equipment room. Every environment is recommended to have a power isolation disconnect control system, either automatic or manual, for depowering of equipment. Manual disconnect controls (e.g. EPO button) may or may not be located at every egress. The fire protection and/or fire alarm will be site specific for the triggering the power isolation disconnect system control panel.

2. The impacted electrical panels will require shunt trip breakers that will shut down power at change of state. Every UPS needs a direct shut-down to take out the battery power as well. Depowering the HVAC equipment directly can be done in lieu of shunt-trip breakers in most cases.

3. The Power Isolation Disconnect Control Panel (reference Darwell Integrated Technology Inc, TripMaster EPO Control):

- a. Receives the trigger inputs and sends the output change of states to the panels and equipment to shut-down power.
- b. The control panel can be placed in 'Test Mode' which will indicate that a trigger event has occurred but will not send the output signals for power isolation.
- c. This provides critical load protection from an accidental shut-down event when work or cleaning is being performed in that space.
- d. This allows testing of signals to the fire protection system without negative impact on the operation of the data processing equipment room.
- e. This allows testing of input triggers, detection to assure the call for power off is active.
- f. Testing the outputs needs to be scheduled by the specific site equipment.

#### **Site Variations that impact the Power Isolation Disconnect Control System Design:**

1. An environment that has separate A/B UPS Rooms may choose to have separate manual disconnect control systems in each room. A trigger event would depower the panels and equipment in that specific space. Power distribution downline from panels in this space would be depowered as well.
2. The power isolation disconnect control system panel will have outputs that take down both A and B Rooms, hence all the power in the data processing equipment room.

#### **Long-term Considerations following Power Isolation Disconnect Control System Installation:**

- Any and all power sources, electrical distribution, back-up and cooling equipment added within the data processing equipment room must be incorporated into the existing power isolation disconnect control system.
- Any modification of the fire alarm and/or fire protection in the data processing equipment room must be incorporated into and tested through the existing power isolation disconnect control System.
- Power Isolation Disconnect Control System testing shall become a vital part of equipment and electrical systems testing.
- Provide appropriate training for all personnel associated with the data processing equipment room following installation and on a periodic basis. A new employee training protocol should include the Power Isolation Disconnect Control System if employee is in the data processing equipment room(s).

#### **APPENDIX F BIBLIOGRAPHY**

British Standard Institute (BSI). Fire protection for electronic equipment installations - *Code of practice*, BS 6266:2011.

Curtis, Peter M. *Maintaining Mission Critical Systems in a 24/7 Environment*. 2nd edition. Hoboken: John Wiley & Sons, Inc, 2011.

European Norm (EN) 50600-2-5:2021. *Information technology – Data centre facilities and infrastructures – Part 2-5: Security systems*.

European Norm (EN) 54-20:2006-09. *Fire detection and fire alarm systems – Part 20: Aspirating smoke detectors* (includes Amendment AC:2008).

Hu, Pearl. "Electrical Distribution Equipment in Data Center Environments", Schneider Electric, White Paper 61, Revision 1.

National Fire Protection Association (NFPA). *National Electrical Code*, NFPA 70, 2014.

National Fire Protection Association (NFPA). *Protection of Information Technology Equipment*, NFPA 75, 2020.



National Fire Protection Association (NFPA). *Fire Protection of Telecommunications Facilities*, NFPA 76, 2020.

Rath, John. *Data Center Knowledge Guide to Modular Data Centers*, October 2011.

Siemens Switzerland Ltd. Building Technologies. "Potential Problems with Computer Hard Disks when Fire Extinguishing Systems Are Released." 2010.

Siemens AG. "Silent Extinguishing, Disruption to Hard Disk Drives Caused by Inert Gas Extinguishing Systems – analysis and measures for the safe operation of storage systems", July 2021.

Thumuluru, S., Ditch, B., Chatterjee, P. and Chaos, M. *Experimental Data for Model Validation of Smoke Transport in Data Centers*. FM Research Technical Report. September 2014.

Tyco Fire Products. "INERGEN Acoustics Testing Position Paper." 2012.

Uptime Technologies, LLC. *Data Center Site Infrastructure Tier Standard: Topology*. Uptime Institute Professional Services, LLC, 2012.

Wagner Group GmbH. "FirExting® SILENT Product Information." Issue 010/10.

Xtralis. *Telecommunications and Data Processing Facilities - Design Guide*, July 2007.